

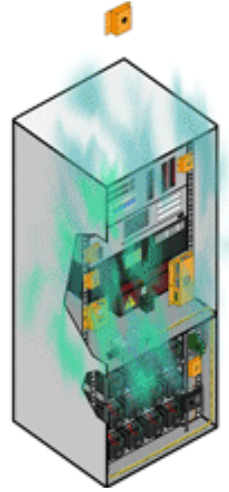

Ammonia (NH3) Gas Sensor (GAS-NH3)

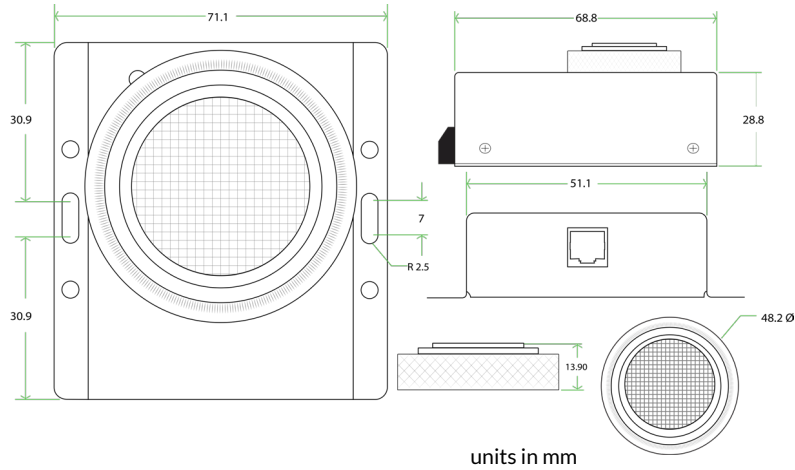

Digital sensor designed for monitoring and measuring the level of Ammonia (NH3) in the ambient air.

Sensor Metrics:

Measurement range	0-100 ppm
Maximum detection	200 ppm
Response time (T90)	<90 seconds
Warmup time	10 minutes
Calibration frequency	up to 1 year
Life span	1 year
Cross sensitivity	Hydrogen Sulfide (H2S)
Detection technology	Electrochemical

Technical Specifications:

Powered by and communicates with	Base Unit (BASE-XX) (required) Requires the optional BASE-FW-SSLS firmware add on for the Base Unit
Connectivity	RJ45 cable transmitting data & power from Base Unit to Sensor
Cable specification	RJ45 CAT 6/7 recommended Up to 100m (330ft) subject to cable quality & interference
Sensor power usage	1152mW

Environmental Specifications:

Operating temperature range	-10°C to +60°C (14°F to +140°F)
Humidity (operating and storage)	0-95% rH (non-condensating)

Physical Specifications:

Sensor enclosure	Steel enclosure, industrial grade
Mounting option	0U rack, DIN rail, magnetic, or wall mountable sensor
Dimensions	71.1mm (2.8") x 68.8mm (2.71") x 28.8 mm (1.13")
Weight	193g (0.43lbs)