

# ASD 533

## Aspirating Smoke Detector

Technical description  
as of firmware version 01.11.xx



---

**Manufacturer:**

Securiton AG  
Alpenstrasse 20  
3052 Zollikofen, Switzerland  
[www.securiton.ch](http://www.securiton.ch)

The product (hardware, software and technical documentation) is subject to the copyright of the manufacturer. Any prohibited modification, misuse, copying or prohibited sale of this product represents a violation of the copyright and will be legally prosecuted.

Copyright by Securiton AG

---

## Validity



### Notice

This document is valid only for the product described in this chapter and may be changed or withdrawn without prior notice. The validity of the statements made in this document applies until the statements are revised by a new edition of the document (T number with new index). The user of this document is responsible for staying up to date with its current status through the editor/publisher. We accept no responsibility for claims against any incorrect statements in this document that were unknown to the publisher at the time of publication. Handwritten changes and additions are invalid.

Foreign language documents as listed in this document are always released or changed at the same time as the German edition. If there are inconsistencies between the foreign language document and the German document, the German text is binding.

Some words in this document are highlighted in **blue**. These terms and designations are the same in all languages and are not translated. Users are encouraged to contact the editor/publisher if there are statements which are unintelligible, misleading, incorrect or which contain errors.

This document is intended for trained specialists for mounting, installation, commissioning and maintenance of the product.

This document is available in the following languages:	German	T 140 287 de
	English	T 140 287 en
	French	T 140 287 fr
	Italian	T 140 287 it
	Spanish	T 140 287 es
	Korean	T 140 287 ko
	Portuguese	T 140 287 pt
	Russian	T 140 287 ru
	Swedish	T 140 287 sv
	Thai	T 140 287 th
	Vietnamese	T 140 287 vi

Current edition:      Index g      31.10.2023      Po/Ksa



### Notice

The following document is applicable only to the ASD 533 aspirating smoke detector with the following production version and firmware version:

<b>Production version</b>	<b>Firmware version</b>
as of 311023	as of 01.11.xx

The validity of older production versions and firmware versions is guaranteed, with the exception of the new functionalities described in this edition. Additional information about the new functionalities can be found in the document history.

## Validity

### Other documents

Data sheet ASD 533		T 140 288	de / en / fr / it / es / ko / pt / ru / sv / th / vi
Material for the sampling pipe		T 131 194	multilingual (ED / FI)
Commissioning protocol		T 140 299	multilingual (EDFI)
Data sheets	XLM 35	T 140 088	de / en / fr / it / es / pt / ru / sv
	ML-SFD	T 140 822	de / en / fr / it / es / pt / ru / sv
	SLM 35	T 131 197	de / en / fr / it / ru
	RIM 35	T 131 196	de / en / fr / it / ru
	MCM 35	T 131 195	de / en / fr / it / ru
	SIM 35	T 140 011	de / en / fr / it / es / pt / ru / sv
	MCM 35	T 131 195	de / en / fr / it / ru
Installation instructions for aspirating fan unit		T 131 200	multilingual (EDFI)

## Table of contents

<b>1</b>	<b>General information</b>	<b>9</b>
1.1	Purpose	9
1.2	Safety and the environment	11
1.2.1	Notice and warning symbols	11
1.2.2	Safety information	12
1.2.3	Disposal	12
1.3	Uses and applications	12
1.4	Abbreviations and terms	13
1.5	Product identification	15
1.6	Guarantee	15
1.7	Product changes	15
1.8	Limitation	16
<b>2</b>	<b>Function</b>	<b>17</b>
2.1	General operating principle	17
2.2	Electrical operating principle	18
2.2.1	Power supply	18
2.2.2	Fan control	19
2.2.3	Microcontroller	19
2.2.4	Programming / operation	20
2.2.5	Displays	21
2.2.6	Relays	21
2.2.7	Outputs	22
2.2.8	Inputs	22
2.2.9	Interfaces	22
2.2.10	Airflow monitoring	23
2.2.11	Smoke sensor monitoring	23
2.2.12	Alarm release	24
2.2.12.1	Alarm 2	24
2.2.12.2	Alarm cascading	24
2.2.12.3	Isolating the smoke sensor	24
2.2.13	Autolearning	25
2.2.14	Day/night control / weekday control	26
2.2.15	Fault triggering	26
2.2.16	Event memory	26
2.2.17	Reset types	27
2.2.17.1	State reset	27
2.2.17.2	Hardware reset	27
2.2.17.3	Initial reset	27
2.2.18	ASD network	28
2.2.19	Filter monitoring	28
<b>3</b>	<b>Design</b>	<b>29</b>
3.1	Mechanical design	29
3.2	Electrical	31
3.3	Hardware / firmware	32
3.4	List of materials / components	33
3.5	Packaging	33

## Table of contents

<b>4</b>	<b>Planning</b>	<b>34</b>
4.1	General aspects of planning	34
4.1.1	Standards, regulations, guidelines, approvals	34
4.2	Area of application	34
4.2.1	System limits	35
4.2.2	Usable accessory materials for the sampling pipe	35
4.3	Planning aids	36
4.3.1	Planning with "ASD PipeFlow" calculation	36
4.3.2	Planning without "ASD PipeFlow" calculation	37
4.4	Space surveillance	37
4.4.1	Space surveillance applications	37
4.4.2	Principles of space surveillance	38
4.4.3	Types of sampling pipe layouts for space surveillance	39
4.4.4	System limits for space surveillance without "ASD PipeFlow" calculation	40
4.4.4.1	Normative system limits for space surveillance without "ASD PipeFlow" calculation	40
4.4.4.2	Non-normative system limits for space surveillance without "ASD PipeFlow" calculation	40
4.4.4.3	Table of system limits for planning without "ASD PipeFlow" calculation	41
4.4.4.4	Non-normative system limits table for planning without "ASD PipeFlow" calculation	42
4.4.4.5	Sampling holes for planning without "ASD PipeFlow" calculation	43
4.4.4.6	Maintenance sampling hole	44
4.5	Equipment monitoring	45
4.5.1	Equipment monitoring applications	45
4.5.2	Principles of equipment monitoring	45
4.5.3	Examples of sampling pipe layouts for equipment monitoring	46
4.5.4	System limits for equipment monitoring	46
4.5.4.1	Alarm thresholds for equipment monitoring using sampling fixtures without "ASD PipeFlow" calculation	47
4.5.5	Sampling fixtures and sampling holes in equipment monitoring	48
4.6	Two-detector dependency	49
4.7	Air recirculation	49
4.8	Settings	50
4.9	Electrical installation	51
4.9.1	Installation cable requirements	51
4.9.2	Determining the conductor cross-section	52
4.10	Limitations	53
4.11	Environmental influences	54
4.12	Use compliant with UL 268 7 <sup>th</sup> Ed and ULC-S529 4 <sup>th</sup> Ed	54
4.12.1	Use in USA according to UL 268 7 <sup>th</sup> Ed	54
4.12.2	Use in Canada according to ULC-S529 4 <sup>th</sup> Ed	54
<b>5</b>	<b>Mounting</b>	<b>55</b>
5.1	Mounting guidelines	55
5.2	Dimensioned drawing / drilling plan for the detector housing	55
5.3	Materials for the sampling pipe	56
5.4	Mounting the detector housing	57
5.4.1	Opening and closing the detector housing	58
5.4.2	Mounting positions for the detector housing	59
5.4.3	Removing the air outlet pipe plug	60
5.4.4	Turning the labelling strip	60
5.5	Mounting the sampling pipe	61
5.5.1	General	61
5.5.2	Mounting with PVC tubes and fittings	61
5.5.3	Mounting with ABS tubes and fittings	61
5.5.4	Mounting with metal pipes and fittings	61
5.5.5	Linear expansion	62
5.5.6	Mounting the sampling pipe	63
5.5.7	Mounting for equipment monitoring	64
5.5.7.1	Screw-free fastening of the sampling pipe	64
5.5.7.2	Transition to a flexible tube	65
5.5.8	Creating the sampling holes	66
5.5.9	Mounting the sampling hole clips and maintenance clips	66
5.5.10	Mounting the sampling funnel	66
5.5.11	Mounting sampling stubs for a ceiling bushing	67
5.5.12	Mounting dust filter unit, dust trap box, dust retaining box, water retaining box	68

<b>6</b>	<b>Installation</b>	<b>69</b>
6.1	Regulations	69
6.2	Cable entry	69
6.3	Using the smoke sensors	70
6.4	Installing additional modules	71
6.5	Electrical connection	72
6.5.1	Terminal assignment for the AMB 33 main board	72
6.5.2	Terminal assignment line module XLM 35 / ML-SFD / SLM 35	73
6.5.3	Terminal assignment for RIM 35 relay interface module	73
6.5.4	Terminal assignment of an SIM 35 serial interface module	73
6.6	Connection variants	74
6.6.1	Power supply	74
6.6.2	Reset input	74
6.6.3	Control	75
6.6.3.1	Control via supply voltage by means of auxiliary relay	75
6.6.3.2	Control via the "Reset external" input	76
6.6.4	Interconnecting the FACP line	77
6.6.4.1	Interconnection on zone detection via AI / St relay	77
6.6.4.2	Interconnection on selective identification or addressable loop via AI / St relay	78
6.6.4.3	Interconnection on SecuriPro / SecuriFire / Integral addressable loop from XLM 35 / ML-SFD / SLM 35	78
6.6.5	Open collector outputs	79
<b>7</b>	<b>Commissioning</b>	<b>80</b>
7.1	General	80
7.2	Programming	81
7.2.1	Configuration options	82
7.2.2	Relay allocation	84
7.3	Startup	84
7.3.1	Commissioning using EasyConfig	84
7.3.2	Commissioning with "ASD Config" configuration software	85
7.3.3	Setting to pre-defined switch positions A11 to C32, W01 to W48	86
7.3.4	Setting and polling the date and time	86
7.3.5	Initial reset	87
7.3.6	Displaying the firmware version	87
7.3.7	Logging off additional modules	88
7.4	Re-programming	88
7.4.1	Re-programming on the ASD 533	88
7.4.2	Re-programming with "ASD Config" configuration software	88
7.4.3	Re-programming from SecuriPro / SecuriFire / Integral with SLM 35	89
7.4.4	Re-programming from SecuriFire / Integral with XLM 35 / ML-SFD	89
7.5	Uploading new firmware to the ASD 533	90
7.6	Measurements	91
7.6.1	Reading out the set configuration and airflow	92
7.7	Testing and checking	93
7.7.1	Checking the alarm release	93
7.7.2	Test triggerings	94
7.8	Filter monitoring operation	96
7.9	Commissioning protocol	97

## Table of contents

<b>8</b>	<b>Operation</b>	<b>98</b>
8.1	Control and indicator elements	98
8.2	Functional sequence of operation	99
8.3	Switch positions	100
8.4	Resetting	100
8.5	Displays	101
8.5.1	Displays on the control unit	101
8.5.2	Displays on the AMB 33 Main Board	102
8.5.3	Displaying and reading out the event memory	102
8.5.3.1	Procedure and interpretation of the event memory display	102
8.5.3.2	Event groups	103
8.5.3.3	Event codes within event groups	103
8.5.4	Operation and displays on the XLM 35, SLM 35, ML-SFD	107
8.5.5	Operation and displays on the MCM 35	108
8.5.5.1	Data logging on the MCM 35	108
8.5.6	Indication and control on the SIM 35	109
8.5.7	Indication and control on the SMM 535	110
8.6	Operation from SecuriPro with SLM 35	111
8.7	Operation from SecuriFire / Integral with XLM 35 / ML-SFD	111
<b>9</b>	<b>Maintenance and service</b>	<b>112</b>
9.1	General	112
9.2	Cleaning	112
9.3	Maintenance checks and function checks	113
9.3.1	Filter replacement on dust filter units	115
9.4	Replacing units	116
9.4.1	Replacing the smoke sensors	116
9.4.2	Replacing the aspirating fan unit	116
9.4.3	Replacing the airflow sensor	117
9.4.4	Replacing the AMB 33 Main Board	117
9.4.5	Replacing printed circuit boards BCB 35	117
9.5	Disposal	118
9.5.1	Materials used	118
<b>10</b>	<b>Faults</b>	<b>119</b>
10.1	General	119
10.2	Warranty claims	119
10.3	Finding and rectifying faults	120
10.3.1	Fault states	120
<b>11</b>	<b>Options</b>	<b>124</b>
11.1	Sampling pipe	124
11.2	Use under extreme conditions	124
11.3	Use of detector boxes	124
11.4	ASD network	125
11.4.1	ASD networking to "ASD Config" via RS-485 interface from SIM 35 / SMM 535	125
11.4.2	ASD networking on FidesNet	126
<b>12</b>	<b>Article numbers and spare parts</b>	<b>127</b>
12.1	Detector housings and accessories	127
12.2	Sampling pipe and accessories	127
<b>13</b>	<b>Technical data</b>	<b>128</b>
<b>14</b>	<b>List of figures</b>	<b>129</b>
<b>Document history</b>		<b>130</b>

# 1 General information

## 1.1 Purpose

The ASD 533 aspirating smoke detector performs the task of taking continuous air samples via one or two sampling pipe tube networks from a monitored sector and feeding the samples to one or two smoke sensors. Thanks to this detection method and the product's excellent properties under severe ambient conditions, the ASD 533 aspirating smoke detector is used wherever problems are to be expected owing to poorly accessible monitored areas or latent disturbance variables during operation such that optimal protection can no longer be guaranteed with conventional point detectors.

The ASD 533 aspirating smoke detector is available in the following versions:

- ASD 533-1 for 1 sampling tube, for 1 smoke sensor
- ASD 533-2 for 2 sampling tubes, for 2 smoke sensors

The ASD 533 uses the **SSD 533** smoke sensor. It has an alarm sensitivity range of 0.02 %/m to 10 %/m.

The ASD 533 aspirating smoke detector has four slots for additional modules. The following modules can be fitted:

- XLM 35 SecuriLine eXtended module (only if no ML-SFD or SLM 35 is fitted)
- ML-SFD M-Line module (only if no XLM 35 or SLM 35 fitted)
- SLM 35 SecuriLine module (only if no XLM 35 or ML-SFD is fitted)
- RIM 35 Relay interface module with 5 relays
- MCM 35 Memory card module
- SIM 35 serial interface module (only if no UIM 35 is fitted)
- UIM 35 universal interface module (only if no SIM 35 is fitted)

With the installation of a **XLM 35** SecuriLine eXtended module or **ML-SFD** M-Line module, the ASD 533 aspirating smoke detector can be ideally connected to the fire alarm systems SecuriFire and Integral via the addressable loop. Control operations and changes to the ASD device configuration can be carried out directly from the FACP. For this purpose the FACP user software "SecuriFire-Studio" and "Integral [Application Centre](#)" is used to start the "ASD Config" configuration software for access to the ASDs, the configuration software then being used to make the changes to the ASD 533.

With the installation of an **SLM 35** SecuriLine module, the ASD 533 aspirating smoke detector can be connected to the SecuriPro, SecuriFire and Integral fire detection systems via the addressable loop. Only simple operations and changes can be made to the ASD device configuration from the FACP using the SLM 35.

The **RIM 35** relay interface module is available as a further installation option. This module enables the availability of all three pre-signal levels as well as the states "smoke sensor dirty" and "LS-Ü blockage" as relay contacts. The relays are also freely programmable via the "ASD Config" configuration software.

The **MCM 35** memory card module is used to record operating data.

## General information

The **SIM 35** serial interface module is for networking multiple ASD 533 aspirating smoke detectors via RS-485 bus. Using the “ASD Config” configuration software, all ASD 533 units present in the network can be visualised and operated from a PC. The master module in the ASD network is the SMM 535, by means of which a PC is connected.



### Notice

The normative alarm transmission of the ASD 533 to the higher level point does not use the ASD network. The “Alarm” / “Fault” relays in the ASD, or the SecuriPro- / SecuriFire- / Integral addressable loop are to be used from the XLM 35, ML-SFD or SLM 35.

The **UIM 35** is the in-house designation for a “Universal Interface Module”. This was created for OEM applications and ensures the connection to an OEM system via RS-485 (Modbus protocol) using an OEM own module.

The present technical description contains all information essential for trouble-free operation. For obvious reasons only those details specific to individual countries and companies or special applications can be discussed if they are of general interest.

## 1.2 Safety and the environment

Provided the product is deployed by trained and qualified personnel in accordance with this document, and provided the safety symbols all notices are observed, there is no danger to persons or property under normal conditions and when used properly. The product fulfils the requirements ensuring personal safety and environmental protection during operation. National and state-specific laws, regulations and directives must be observed and adhered to in all cases.

Observe these danger notices. They help prevent accidents and damage.

### 1.2.1 Notice and warning symbols

The following notice and warning symbols are used to draw attention to hazards and special properties.



#### **Danger**

The product may represent an immediate danger with a high level of risk to persons if the notice is not duly observed. If the danger is not avoided, death or serious injury may result.



#### **Warning**

The product may represent a possibly imminent danger with a medium level of risk to persons if the notice is not duly observed. If the danger is not avoided, death or serious injury may result.



#### **Caution**

The product may represent a possibly imminent danger with a low level of risk to persons if the notice is not duly observed. If the danger is not avoided, a minor injury may result.



#### **Notice**

If this notice is not observed, the product may malfunction, may cause property damage, or may be harmful to the environment.

## General information

### 1.2.2 Safety information



#### Read the user instructions

To ensure safe and proper use, it is absolutely necessary to read the instructions and other documentation accompanying the product before use and to keep such documentation at hand for later reference. It is imperative that the danger information in particular is observed.



#### Electrostatic discharge

The product includes electronic components that are sensitive to electrostatic discharge (ESD). Contact with persons or objects can cause an electrostatic discharge that damages or destroys the product. ESD bands for preventing electrostatic discharge are used for grounding persons and for equipotential bonding.



### 1.2.3 Disposal



#### Electrical and electronic devices and batteries

It is not permitted to dispose of electrical and electronic devices or batteries in the domestic rubbish. As the end user you are legally obliged to return them. Used electrical and electronic devices as well as batteries can be returned to the seller or taken to a designated recycling centre (e.g. a community collection point or dealer) at no cost.



#### Recycling

The product and its components including their packaging consist of recyclable material and can be disposed of for recycling purposes as described in this document.



## 1.3 Uses and applications

Thanks to the detection method, air sampling by means of a sampling pipe tube network and the good properties of the product under extreme ambient conditions, the ASD 533 aspirating smoke detector is used wherever problems can be expected owing to poorly accessible areas to be monitored or latent disturbance variables during operation such that optimal protection cannot be guaranteed with conventional point detectors. Examples of such applications:

- **Space surveillance:**  
EDP rooms, ultra-clean rooms, warehouses, hollow floors, protection of cultural assets, transformer stations, prison cells, etc.
- **Equipment monitoring:**  
EDP systems, electrical distributors, switch cabinets, etc.

The ASD 533 is also deployed in areas where conventional point detectors are used. Local regulations and provisions must be observed from case to case.

The response behaviour of the ASD 533 has been tested in compliance with EN 54-20, Class A, B and C.

When control-unit-specific alarm transmitters, line monitoring elements, etc., are used, the ASD 533 can be connected via its potential-free change-over contacts virtually without limit to all common fire alarm systems.

## 1.4 Abbreviations and terms

The following abbreviations and terms are used in this document. The abbreviations for tube material and accessories are listed in a separate document: T 131 194 (see also Sec. 5.3).

µC	= Microcontroller / microprocessor
a / ra / r	= Relay contacts: a = NO (normally open), ra = COM (common), r = NC (normally closed)
ABS	= Acrylonitrile-butadiene styrene (plastic)
AFS 35	= Air Flow Sensor
AFU 35	= Aspirating Fan Unit
AI	= Alarm
AMB 33	= ASD main board
ASD	= Aspirating Smoke Detector
ASD Config	= Configuration software for ASD 533
ASD PipeFlow	= Calculation software for the sampling pipe, "ASD PipeFlow" as of Version 2
BCB 35	= Basic Control Board
CE	= <a href="#">Communauté Européenne</a> (European Community)
DA	= Detection area
Default	= Preset values / settings
DET	= Detector
DIN	= <a href="#">Deutsche Industrie Norm</a> (German industry standard)
DMB	= Detector Mounting Box (third-party detector / OEM)
DZ	= Detection zone
<a href="#">EasyConfig</a>	= Commissioning process without the "ASD Config" configuration software
EDP	= Electronic data processing
EEC	= European Economic Community
EEPROM	= Memory component for system data and ASD configuration
EMC	= Electromagnetic compatibility
EN 54	= European standards for fire alarm systems (DE = DIN, CH = SN, AT = Ö-Norm)
Ex-zone	= Area subject to explosion hazards
FACP	= Fire alarm control panel
FAS	= Fire alarm system
Fault	= Fault
FidesNet	= Fire detection systems Net (networking solution, application name)
<a href="#">Flash</a> PROM	= Memory component for firmware
fm / sm	= Flush mounted / surface mounted
FW	= Firmware
GND	= Supply ground (minus (-) pole)
<a href="#">H-AI</a>	= Main alarm
HF	= High frequency
HW	= Hardware
IEC	= International Electrotechnical Commission
Initial reset	= First start-up on commissioning
IPS 35	= Insect Protection Screen
LED	= Light-emitting diode (indicator)
<a href="#">LS</a>	= Airflow
<a href="#">LS-Ü</a>	= Airflow monitoring
Manufacturer	= Securiton
MCM 35	= Memory Card Module
ML-SFD	= M-Line-Special Fire Detector
NCU	= Network communication unit to the FidesNet "Network Communication Unit" (FidesPort)
<a href="#">NCU Config</a>	= Web application for configuring the FidesNet
OC	= Open collector output
OEM	= Original Equipment Manufacturer (reseller)



## General information

Continuation:

PA	= Polyamide (plastic)
PC	= Personal computer
PC	= Polycarbonate (plastic)
PE	= Polyethylene (plastic)
Pin	= Terminal pin
PMR 81	= Semi-conductor relay
Port	= Input or output component
PVC	= Polyvinyl chloride (plastic)
RAM	= Memory component
RCU	= FidesNet remote control unit "Remote Control Unit" (FidesControl)
RIM 35	= Relay interface module
RoHS	= Restriction of Certain Hazardous Substances (eco-friendly manufacturing processes)
SecuriFire	= FAS system
SecuriLine	= Fire detector addressable loop
SecuriPro	= FAS system
SIM 35	= serial interface module
SLM 35	= SecuriLine module
SMM 535	serial master module
SSD 533	= Smoke sensor
St	= Fault
St-LS	= Airflow fault
SW	= Software
Te.	= Terminal
UIM 35	= universal interface module (RS-485)
UMS 35	= universal module support
Update / Release	= Renewal / updating of the firmware
V-AI	= Pre-alarm
VDC	= Direct current voltage
VdS	= <a href="#">VdS Schadenverhütung GmbH (DE)</a> "Association of indemnity insurers, Germany"
VKF	= <a href="#">Vereinigung Kantonalen Feuerversicherungen</a> "cantonal fire insurance union, Switzerland"
VS	= Pre-signal
Watchdog	= Monitoring of the microcontroller
XLM 35	= SecuriLine eXtended module

### 1.5 Product identification

For identification, the ASD 533 and its units have inscription plates or identification plates.

The following product identifications apply:

#### Rating plate on the ASD 533 and identification on the packaging

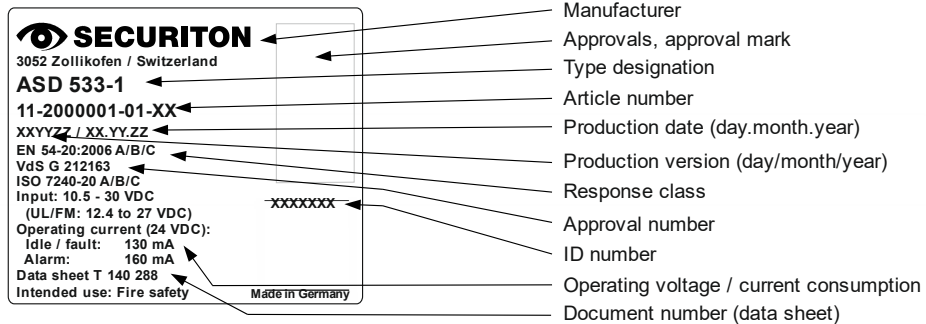

#### Notice

The rating plates, type designations and/or identifications on devices and printed circuit boards must not be removed, written over or defaced in any way.

Many products, such as accessories and mounting materials, are identified only with a sticker showing the article number. The manufacturer identifies these parts by article number.

### 1.6 Guarantee



#### Notice

The product may be operated only with the hardware, software and commissioning media designated and delivered by the manufacturer. Any unauthorised intervention in the hardware and/or software or the use of non-system products is prohibited and may result in malfunctions and/or damage to the product. If this is not observed, all guarantee and warranty rights with respect to the manufacturer of the product will become null and void. Further, non-observance of the user instructions as well as improper maintenance and repair work void the guarantee and product liability.

### 1.7 Product changes

The hardware is considered to comprise the complete detector housing and all the units belonging to the ASD 533 aspirating smoke detector such as sampling pipe and mounting material.

The firmware is stored on the **Flash-PROM** in the ASD 533. An EEPROM is fitted for storing and saving system-specific parameters.



#### Notices

- The ASD 533 is to be operated only with the appropriate original firmware from the manufacturer. Any unauthorised intervention on the firmware or the use of non-original firmware may result in malfunction and/or in damage to the device. Furthermore, all guarantee and warranty rights with respect to the manufacturer of the ASD 533 will become null and void as a result.
- We recommend always using the most recent SW version. In the event of changes by the manufacturer to the hardware or software of a product, there is no guaranteed update for existing systems.

### 1.8 Limitation



#### Notice

Only the smoke sensor specified in the device approval and on the list below may be used in the ASD 533 aspirating smoke detector. The use of other smoke sensors or third-party detectors voids the ASD 533 approval issued by the manufacturer.

The ASD 533 is fitted with the **smoke sensor SSD 533** by the manufacturer. It has an alarm sensitivity range of 0.02 %/m to 10 %/m.

The response sensitivity of the smoke sensor can be adjusted within the range specified above. Depending on the application in accordance with EN 54-20, Class A, B or C, the value is specified via AMB 33 (pre-defined switch positions as described in Sec. 4.4.4 to 4.4.4.3) or based on planning specifications using the “ASD PipeFlow” calculation software via the “ASD Config” configuration software (see Sec. 7.2.1).

For use compliant with **UL 268** and **ULC-S529** the alarm sensitivity ranges must be configured as specified in Sec. 4.12.

## 2 Function

### 2.1 General operating principle

In the sampling pipe tube networks, the fan generates a vacuum which results in fresh air continuously reaching the detector housing via the sampling pipes. In this way the smoke sensors are constantly supplied with new air samples from the monitored areas. Should the smoke concentration exceed the permissible value, the ASD 533 triggers an alarm. The alarm is indicated visually on the ASD 533 and can be transmitted via a potential-free change-over contact to a superordinate fire alarm control panel.

The operational reliability of the aspirating smoke detector depends on the functional reliability of the smoke sensors and on the constant air supply to the system. A fan failure, blockage of the sampling holes or pipe breakage must be communicated to the fire alarm control panel in the form of a fault signal. This condition is met with the airflow monitoring of the ASD 533.

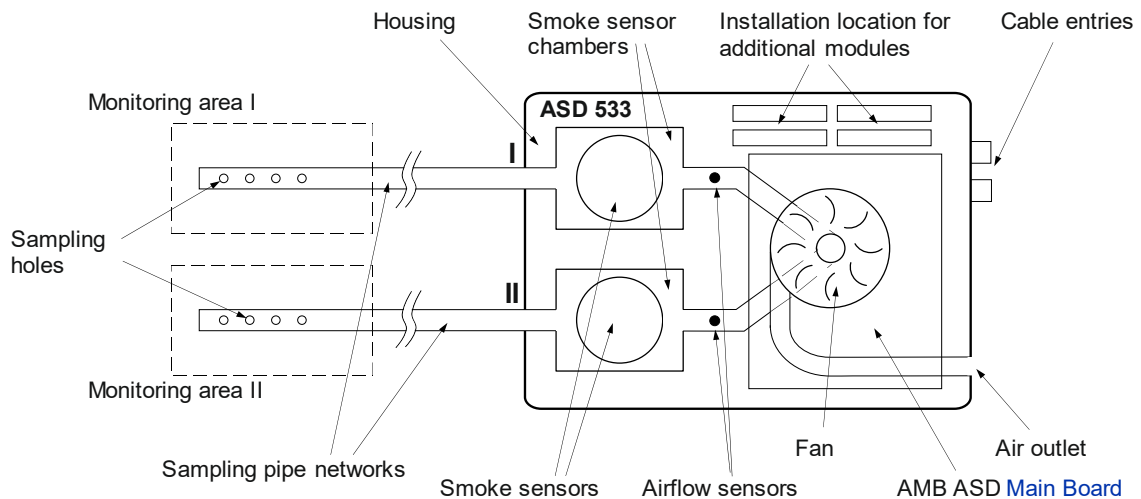

**Fig. 1 General operating principle**

## 2.2 Electrical operating principle

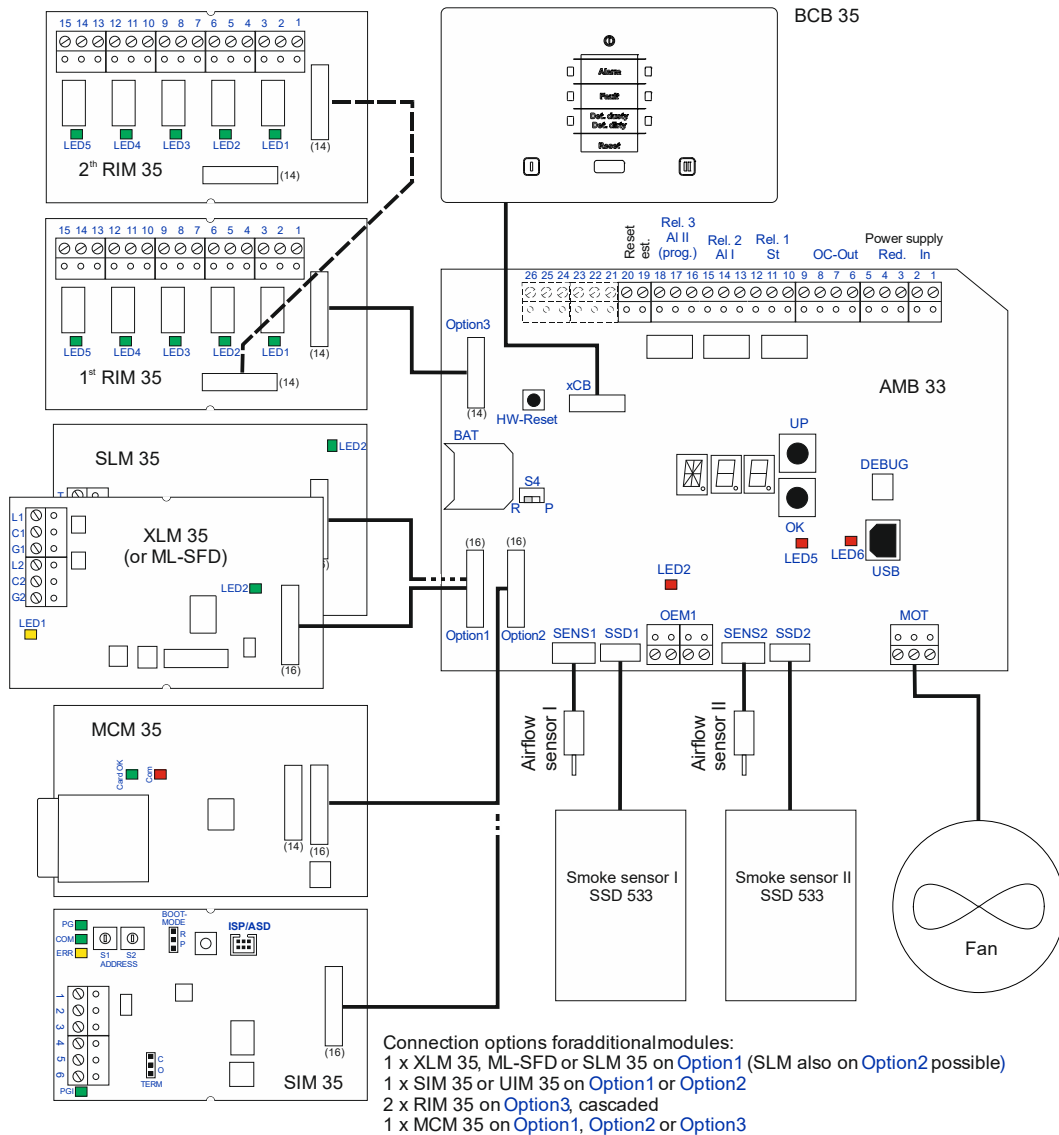

Fig. 2 Block diagram

### 2.2.1 Power supply

The operating voltage of the ASD 533 is +10.5 to +30 VDC (UL/FM = 12.4 to 27). On the AMB 33 main board, 5 VDC of the operating voltage is diverted for internal voltage use.

The operating voltage is monitored on the AMB 33 for undervoltage. If the operating voltage falls below 10.4 VDC (+0 / -0.3 VDC), the ASD 533 triggers an undervoltage fault.

### 2.2.2 Fan control

The physical and electrical properties of a fan cause a brief power surge when it is switched on and starts up, which in turn affects the conductor dimensioning and the total power consumption of the fire alarm system.

A specially designed circuit therefore ensures that the fan cannot exceed a specific maximum power consumption in its start-up phase. When the ASD 533 is switched on, the computer-controlled fan speed starts up slowly. After the fan has been powered up, the speed is kept constant.

Any blocking of the fan is detected by the evaluation of the motor current. If the specified threshold is exceeded, the fan supply is switched off and a fault is signalled.

Depending on the version, the aspirating smoke detector ASD 533 has either one or two fan speeds:

- ASD 533-1    only Level I            **2,500 rpm** at a fan voltage of **12.5 VDC** ( $\pm 1$ )
- ASD 533-2    Level I                    **2,500 rpm** at a fan voltage of **12.5 VDC** ( $\pm 1$ )
- Level II (default)       **2,850 rpm** at a fan voltage of **14.4 VDC** ( $\pm 1$ )



#### Notices

- The fan voltage depends on the ambient temperature of the sampled air when the speed remains constant and may vary in the above specified ranges. The fan voltage specification is an approximate value and serves merely as a check value for maintenance work.
- The fan speed level of the ASD 533-1 cannot be modified.
- The fan speed levels of the ASD 533-2 can be changed only with the "ASD Config" configuration software. For applications and commissioning **without** "ASD Config" configuration software, **Level II** is always set.
- After the fan speed of the ASD 533-2 has been changed, it is **imperative** that a new initial reset is carried out (observe waiting time of at least 5 min).

### 2.2.3 Microcontroller

The entire program and switching sequence is controlled by a microcontroller. The firmware is stored on a [Flash PROM](#). System-specific configurations are stored in an EEPROM.

The program is monitored by the internal watchdog of the microcontroller. In the event of a failure of the microcontroller circuit, an emergency fault is triggered. This is signalled on the device by the steady lit "[Fault](#)" LED. The "Fault" relay switches.

2.2.4 Programming / operation

The operation of the ASD 533 aspirating smoke detector in normal mode (after commissioning) is limited to switching On/Off or resetting a triggered event (alarm/fault). Operation is generally by means of the FACP, with input of the “Zone On/Off” and “Reset” functions (on “Reset external” input of the ASD 533).

Events triggered on the ASD 533 can be reset locally using the “Reset” key on the control unit or by briefly actuating the “Reset External” input. The reset can be performed only if the triggered event is no longer pending (e.g. smoke sensor no longer has smoke). Imposing a continuous signal at the “Reset external” input also deactivates (switches off) the ASD 533 (see also Sec. 2.2.8 and 6.6.2).



**Notice**  
A local reset does not reset a higher-order FACP. The higher-order line of the FACP may trigger a fault as a result of resetting the ASD 533.

To aid commissioning the ASD 533, there are two 7-segment displays, an alphanumeric display, and two keys (“UP” and “OK”) inside the device on the AMB 33 Main Board. These elements provide a type of rotary switch function, i.e. displays and positions in the range **A00** to **Z99** may appear.

Commissioning the ASD 533 can be performed with these elements. Device settings for predefined system limits can also be called up – **EasyConfig**. These pre-defined settings contain normative values concerning response sensitivity, airflow monitoring (LS-Ü) and pipe configuration. They also contain settings which allow deviations from the normative limits concerning airflow monitoring. The **EasyConfig** process allows the device to be commissioned without the “ASD Config” software. If system-specific programming has to be performed (e.g. after a calculation with “ASD PipeFlow” or when programming RIM 35), the “ASD Config” configuration software must be used.

Fig. 3 below shows the workflow for specifying and programming the project-related device functions.

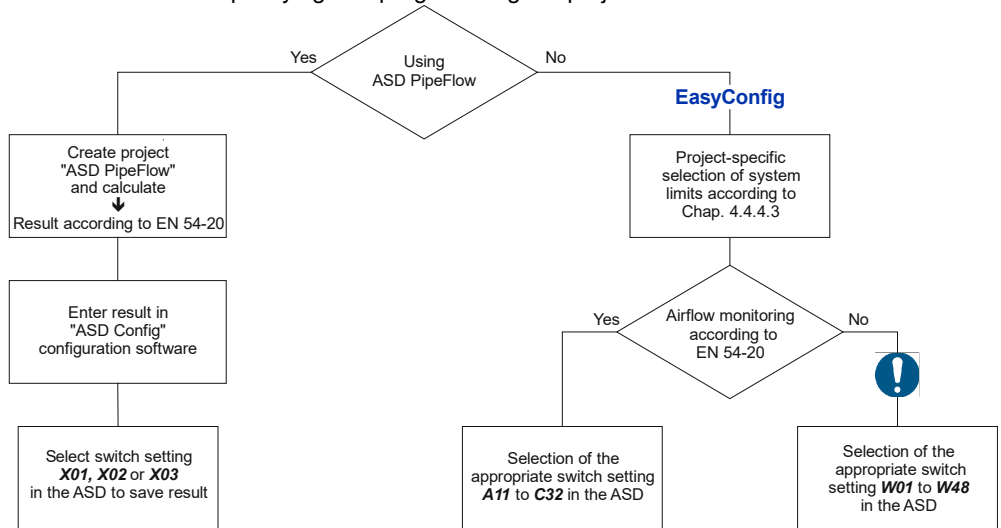



Fig. 3 Workflow for project-related programming



**Notice**  
Switch positions **W01** to **W48** are to be used only after prior consultation with the manufacturer. The airflow monitoring values stored under those switch positions are not tested in accordance with EN 54-20.

The description of the predefined positions and the operator structure can be seen in Sec. 4.4.4.3, 4.4.4.4, 7.2.1 and 8.3.

## 2.2.5 Displays

The following events are indicated by LEDs on the control unit. Various indicators are present depending on the version of the device:

- ASD 533-1 operation, fault I, alarm I, pre-signal I.1–I.3, smoke sensor dirty I
- ASD 533-2 additionally: fault II, alarm II, pre-signal II.1–II.3, smoke sensor dirty II

Depending on the event, the LEDs may be continuously lit or flash with different frequencies (see Sec. 8.5).

## 2.2.6 Relays

Depending on the device version and the additional modules installed, the ASD 533 has several relays with potential-free changeover contacts with the following assignments:

Unit	Relay designation	Version	Function, event
AMB 33	Rel. 1: ① Fault	all	Fault (all events) ASD inactive
	Rel. 2: Alarm I	all	Smoke sensor I alarm triggering
	Rel. 3: ② Freely programmable or Alarm II	ASD 533-1  ASD 533-2	Freely programmable  Smoke sensor II alarm triggering
1 <sup>st</sup> RIM 35 (from AMB 33)	Rel. 1 ②	all	Pre-signal 1 of smoke sensor I or freely programmable
	Rel. 2 ②		Pre-signal 2 of smoke sensor I or freely programmable
	Rel. 3 ②		Pre-signal 3 of smoke sensor I or freely programmable
	Rel. 4 ②		Smoke sensor I dirt or freely programmable
	Rel. 5 ②		Sampling pipe I blockage or freely programmable
2 <sup>nd</sup> RIM 35 (cascaded from 1 <sup>st</sup> RIM 35)	Rel. 1 ②	ASD 533-1	Freely programmable
	Rel. 2 ②		Freely programmable
	Rel. 3 ②		Freely programmable
	Rel. 4 ②		Freely programmable
	Rel. 5 ②		Freely programmable
2 <sup>nd</sup> RIM 35 (cascaded from 1 <sup>st</sup> RIM 35)	Rel. 1 ②	ASD 533-2	Pre-signal 1 of smoke sensor II or freely programmable
	Rel. 2 ②		Pre-signal 2 of smoke sensor II or freely programmable
	Rel. 3 ②		Pre-signal 3 of smoke sensor II or freely programmable
	Rel. 4 ②		Smoke sensor II dirt or freely programmable
	Rel. 5 ②		Sampling pipe II pipe blockage or freely programmable



### Notices

- ① The "Fault" relay has picked up in the normal state → contact Te. 12/10 closed, 12/11 open (ASD 533 under voltage; no fault event present).
- ② The relays are configured with the aforementioned criteria (1<sup>st</sup> RIM 35) or freely programmable using the "ASD Config" configuration software (see also Sec. 7.2.1 and 7.2.2).

## Function

### 2.2.7 Outputs

There are three open collector outputs (OC 1 to OC 3) on the ASD 533. Parallel indicators, feedback indicators or other consumers (relays) can be connected to these outputs. The outputs are configured with the following criteria (see also Sec. 6.6.5):

Unit	OC designation	Version	Function, event
AMB 33	OC 1: Fault	all	Fault (all events) / ASD inactive
	OC 2: Alarm I	all	Smoke sensor I alarm triggering
	OC 3: ①	ASD 533-1	Freely programmable
	Freely programmable or alarm II	ASD 533-2	Smoke sensor II alarm triggering



#### Notice

- ① The OC output is freely programmable using the “ASD Config” configuration software (see also Sec. 7.2.1 and 7.2.2). OC output 3 **always** actuates the same criterion as relay 3.

### 2.2.8 Inputs

The ASD 533 has an “Reset external” input used to reset the device to its normal state after an event. The input is potential-free (opto-isolator). It can be actuated both on the “plus” and on the “minus” side. The input operates in the 5 to 30 VDC range and has a pulse bandwidth of 0.5 to 10 s. When a continuous signal is imposed for longer than 20 s, the ASD 533 is deactivated (fault state), see also Sec. 6.6.2. Switching inactive via the “Reset external” input works only if no XLM 35, ML-SFD or SLM 35 is fitted to the ASD 533.

The “OEM1” inputs are for actuating alarms and faults from third-party detectors. The “OEM1 / St” input can also be activated for the day/night control. This function then has priority over triggering from a third-party detector. The input is potential free (optocoupler) and can be actuated “plus” or “minus” side in the range of 5 to 30 VDC. The inputs are potential-free (opto-isolator) and can be actuated “plus” side or “minus” side in the range of 5 to 30 VDC. By default the inputs are not enabled and must be parameterised using the “ASD Config” configuration software (smoke sensor operation mode). They control the alarm and fault states on the ASD (relay + LED). The same delay times and latching states as for triggering from the SSD 533 apply.



#### Notices

- In some cases actuations via the OEM1 inputs may **not** comply with requirements **in accordance with EN 54-20** and may therefore only be used after consulting with the manufacturer.
- The inputs are **not** line-monitored.

### 2.2.9 Interfaces

Depending on installed additional modules, the ASD 533 has the following interfaces:

Unit	Designation	Function, event
AMB 33	USB	Configuration with “ASD Config” / Firmware upgrade
XLM 35	L1 / C1 / G1 // L2 / C2 / G2	SecuriFire / Integral addressable loop
ML-SFD	P1 / N1 / S1 // P2 / N2 / S2	SecuriFire / Integral addressable loop
SLM 35	T / U / V // X / Y / Z	SecuriPro / SecuriFire / Integral addressable loop

### 2.2.10 Airflow monitoring

Airflow monitoring is based on the calorimetric measuring method (mass flow rate measuring method).

An airflow sensor is installed in the detector housing in such a way that any change in the sampling pipe (pipe breakage, pipe blockage) can be evaluated.

If there is an initial reset of the device and the sampling pipe is intact, the data of the airflow measurement is registered and saved as reference values (100%). The system sets the values in the middle of an electronically formed monitoring window. In the event of a shift of the values (actual values) out of the monitoring window ( $\pm xx\%$ ) owing to pipe blockage or pipe breakage in the sampling pipe, the ASD 533 triggers an "airflow fault". The monitoring window can be set to different sizes on the ASD 533.

A variable delay time ensures that disturbance variables, e.g. air turbulence, are ignored. To handle fluctuations in the ambient temperature, the ASD 533 is equipped with a temperature compensation circuit.



#### Notice

A requirement for the correct operation of the airflow monitoring is that the airflow is logged when the ASD 533 is commissioned. With the triggering of an initial reset, the data is acquired and saved in the ASD 533 as reference values (see also Sec. 2.2.17, "Reset types").

According to **EN 54-20** any change in the airflow greater than  $\pm 20\%$  must be signalled as a fault. After the initial reset the airflow is displayed as 100 % in the ASD 533 aspirating smoke detector when the sampling pipe is correct and clean. In the switch positions **A11** to **C32** any change in this value greater than  $\pm 20\%$  – i.e. below 80 % (soiling/pipe blockage) or above 120 % (pipe breakage) – triggers an "airflow fault" after the LS-Ü delay time of **300 s** has expired.



#### Notice

Switch positions **W01** to **W48** are stored with airflow monitoring values which are **not** tested according to **EN 54-20** and may therefore only be used after consulting with the manufacturer.

### 2.2.11 Smoke sensor monitoring

The smoke sensors used on the ASD 533 are monitored on the AMB 33 main board. A failure of the sensor electronics, a dusty or dirty smoke sensors are registered as an event code and displayed as a state or fault (dust; only state display, fault triggering only via RIM 35). Likewise, the connection line between the smoke sensors and the AMB 33 is monitored and a fault is signalled if there is a failure.

To avoid false alarms, the SSD 533 smoke sensors used in the ASD 533 have a technical measure (TM) for comparing fire characteristic patterns (measure for verifying the alarm state compliant with DIN VDE 0833-2).

### 2.2.12 Alarm release

The smoke sensors cyclically transmit their states as well as the signal amplitude / smoke level to the AMB 33 main board. The states of the smoke sensors are processed further on the AMB 33. If the set limits (alarm, pre-signal 1–3) are exceeded, the corresponding state “**Alarm**”, “**Pre-signal 1 – 3**” is triggered on the ASD 533.

#### 2.2.12.1 Alarm 2

Using the “ASD Config” configuration software, it is possible to activate an additional “**Alarm 2**” for each smoke sensor installed in the ASD 533. When activated, that alarm is **always above** the smoke sensor “**alarm**” described in Sec. 2.2.12 (minimum 20%). If the set limit for Alarm 2 is exceeded, no additional display is actuated on the ASD 533. Alarm 2 can also be programmed on a RIM relay. Alarm 2 is always a follow-up alarm to the EN 54-20 alarm and is therefore not subject to the response requirements of EN 54-20. The setting options for Alarm 2 using the “ASD Config” configuration software can be found in Sec. 7.2.1 (Table A).

#### 2.2.12.2 Alarm cascading

The “ASD Config” configuration software offers the possibility of activating a cascading scenario for the alarm release. This means that the activated pre-signals 1 to 3 and the alarm are triggered one after the other according to the set delay times (pre-signal delay and alarm delay).



#### Notice

- The cascading function may not comply **with EN 54-20** requirements and may therefore only be used after consulting with the manufacturer.
- When used according to **UL 268** and **ULC-S529** it is to be noted that the ASD 533 employs a maximum alarm verification time delay of **30 s** (adjustable).

#### 2.2.12.3 Isolating the smoke sensor

This function is used to place the ASD 533 in an isolated state using the ASD Config configuration software (per smoke sensor). This means that test alarms can then be triggered on the ASD 533 without activating superordinate systems (FACP) (relays / OC outputs / SLM / XLM / ML-SFD do not trigger). When the “Isolate” function is switched on, a fault is triggered on the ASD and forwarded to the superordinate centre. On the ASD the “Fault” LED is then continuously lit.

The “Isolate” state is also triggered when the “Filter replacement” procedure is activated (see Sec. 2.2.18 and 7.8).

### 2.2.13 Autolearning

With the [Autolearning](#) function the ASD 533 is able to monitor the ambient air that reaches the system via the sampling pipe over a defined period of time (adjustable from one minute to fourteen days); based on those results it can then determine the ideal alarm release threshold for the smoke sensors. This prevents any operational disturbance variables such as dust, vapour or smoke from triggering false alarms on the ASD 533. It means it is also possible to set a highly sensitive trigger threshold (far below the trigger threshold requirements of EN 54-20), for example for clean rooms. During [Autolearning](#) the smoke sensor's biggest amplitude is determined and then multiplied by an adjustable factor of 1.1 to 10 to define the definitive trigger threshold. However the definitive trigger threshold can never be lower than the minimum possible trigger threshold (see example 2) and not greater than the trigger threshold required for complying with EN 54-20 (see example 3). If the day/night control is activated, the values for both time periods are determined separately.

Example 1:

- Smoke sensor type = SSD 533 (0.02–10%/m)
- Required trigger threshold as per system limit and “ASD PipeFlow” for EN 54-20, Class C = 0.4%/m
- Selected [Autolearning](#) factor = 2
- Maximum amplitude (smoke level) during [Autolearning](#) = 31%/m

Calculation:  $0.31 \times 2 \times 0.4\%/m = 0.248\%/m$

Result: Smoke sensor trigger threshold = **0.248%/m**

Example 2:

- Smoke sensor type = SSD 533 (0.02–10%/m)
- Required trigger threshold as per system limit and “ASD PipeFlow” for EN 54-20, Class A = 0.03%/m
- Selected [Autolearning](#) factor = 1.1
- Maximum amplitude (smoke level) during [Autolearning](#) = 50%/m

Calculation:  $0.5 \times 1.1 \times 0.03\%/m = 0.0165\%/m$

Result: Smoke sensor trigger threshold = **0.02%/m** (minimum possible trigger threshold for the SSD 533)

Example 3:

- Smoke sensor type = SSD 533 (0.02–10%/m)
- Required trigger threshold as per system limit and “ASD PipeFlow” for EN 54-20, Class C = 0.2%/m
- Selected [Autolearning](#) factor = 10
- Maximum amplitude (smoke level) during [Autolearning](#) = 16%/m

Calculation:  $0.16 \times 10 \times 0.2\%/m = 0.32\%/m$

Result: Smoke sensor trigger threshold **remains on 0.2%/m to ensure compliance with EN 54-20, Class C**



#### Notices

- Norm-compliant alarm release during [Autolearning](#) is guaranteed; the procedure is interrupted. Likewise, [Autolearning](#) is interrupted if in the meantime the configuration is changed (change within the switch positions **A11 – C32**, **W01 – W48** and **X01 – X03**). If there is a power interruption on the ASD (power supply line) during [Autolearning](#), it will be restarted once the supply voltage is restored. In the event of a disablement (triggered from the FACP or using “Reset External”), [Autolearning](#) is interrupted and then re-started after re-activation. Also for “Isolate” and “Filter replacement”, [Autolearning](#) is interrupted and restarted after revoking the concerned state.
- [Autolearning](#) can only be used with the “ASD Config” configuration software and in switch positions **X01 – X03**.
- During [Autolearning](#) both the point (watchdog display) and the **AL** text flash on the segment display.

### 2.2.14 Day/night control / weekday control

The ASD 533 can be adapted to operational processes (e.g. if dust, vapour and/or smoke are produced during working hours) using the day/night control. When the day/night control is activated, different trigger thresholds, pre-signal allocations (smoke level only, not relays) or LS-Ü parameters can be assigned for each time slot (see Sec. 2.2.13).



#### Notices

- Improper parameter changes in day/night operation may result in non-compliance with the EN 54-20 norm.
- Day/night control can be used only via the “ASD Config” configuration software.
- The activation of the day/night control can be performed from the ASD clock (in accordance with time/weekday program in “ASD Config”), FACP or via the OEM input “**OEM1 / St**”.
- Day/night control is effective only in switch positions **X01 – X03**.
- On non-activated days of the week, night mode of operation is always selected (when activating from the ASD clock).
- In addition to the watchdog indicator (flashing point in the left segment display), the point is also continuously lit on the right segment display whenever the day/night control is active (only with the selected switch positions **X01 – X03**).

### 2.2.15 Fault triggering

If a fault event occurs on the ASD 533, the “Fault” relay becomes currentless and the “**Fault**” is activated. In the event of a fault the fault profile can also be localised using the event code display on the AMB 33 (switch position **E**) (see also Sec. 8.5.3.3 and 10.3.1). The following events trigger a fault (list is incomplete):

- Fault: airflow (after expiry of **LS** delay time)
- Fault: fan (fan limit data exceeded or fallen short of, tacho signal)
- Fault: initial reset
- Fault: smoke sensor dirty
- Fault: smoke sensor missing; communication disrupted; other
- Fault: AMB 33 communication with control unit
- Fault: AMB 33 communication with XLM 35 / ML-SFD / SLM 35 / RIM 35 / MCM 35 / SIM 35 / UIM 35 (individual)
- Emergency fault (microcontroller failure)
- Fault: undervoltage (10.4 VDC, +0 / –0.3 V)
- Fault: power supply (no voltage on the ASD, no “**Fault**” display)
- ASD inactive via “Reset external” input.



#### Notice

The “Fault” relay has picked up in the release state → contact Te. 12/10 closed, 12/11 open (ASD 533 under voltage; no fault event present).

### 2.2.16 Event memory

The ASD 533 has an event memory capable of storing up to 430 events. The latest (i.e. most recent) event is always placed in the first position. If the memory exceeds 430 events, the oldest event is deleted. The event memory as a whole can only be deleted by the manufacturer. The event memory can be read out directly on the ASD 533 using the rotary switch function (switch position **E** = last 99 events, see Sec. 8.5.3) or using the “ASD Config” configuration software (up to 430 events can be selected).

### 2.2.17 Reset types

All events triggered on the ASD 533 go into latching mode whenever the default configurations are used. To reset, carry out a state reset.

The following reset types are possible (see Sec. 2.2.17.1 to 2.2.17.3).

#### 2.2.17.1 State reset

A state reset is triggered by pressing the “Reset” key on the control unit or by actuating the “Reset external” input (see also Sec. 6.6.2). The state reset can be triggered only after an event, and only if the criterion that resulted in the event trigger is back in the normal state (e.g. smoke level in the smoke sensor is again below the trigger threshold or a fault event is rectified). As a result of the state reset, the ASD 533 continues to run “normally” and the fan does not stop.

#### 2.2.17.2 Hardware reset

A hardware reset is triggered if there is a brief interruption in the supply voltage or if the “HW reset” key is briefly pressed on the AMB 33 (see also Fig. 40 and Fig. 45). This restarts the ASD 533. The fan stops and then slowly starts up again (start-up control). The previously programmed parameters of the ASD 533 are retained (system-specific configurations).



#### Notice

##### Attention: fire incident control, remote alerting!

A hardware reset briefly triggers the fault relay (approx. 1 s). So before maintenance work is carried out on the ASD 533, it is essential to switch off the fire incident controls and remote alerting on superordinate systems (FACP).

#### 2.2.17.3 Initial reset

An initial reset is triggered according to the information in Sec. 7.3.5.

With an initial reset, the currently valid airflow measuring values are read in and saved. All subsequent airflow changes take the measuring values at the time of the initial reset as a basis. An initial reset does not discard the previously defined installation-specific parameters (system limits, response grade).



#### Notices

- During commissioning and after any changes to the sampling pipe (length, repairs) or after changing the fan speed on the ASD 533-2 **it is imperative** to carry out an initial reset. An initial reset must also be carried out after repair work on the ASD 533 (replacement of airflow sensor, aspirating fan unit, AMB 33 Main Board).
- After a firmware upgrade, an initial reset is required only if expressly mentioned in the relevant firmware description.
- When carrying out an initial reset, make sure the sampling pipe has been correctly implemented (sealed connecting points, sampling holes correctly drilled).
- If a further initial reset has to be repeated because a triggered fault in the airflow monitoring cannot be reset, it may be done only if **all** necessary measures for cleaning the sampling pipe have been implemented beforehand (including dust filter unit, see also Sec. 9.3). If an initial reset is carried out with blocked or dirty sampling holes, there is the danger that insufficient or no air samples will be taken and hence the ASD 533 will no longer be able to trigger an alarm.
- Before carrying out an initial reset, allow the fan to run for a minimum of 5 min (after switching on or after making changes to the sampling pipe).

### 2.2.18 ASD network

An ASD network can be implemented by using the SIM 35 and SMM 535 or SIM 35 and FidesNet additional modules. Please refer to Sec. 11.4 ff for more information.

### 2.2.19 Filter monitoring

If a dust filter unit is installed in the sampling pipe (per smoke sensor), it can be monitored by means of connectible filter monitoring functions. The degree of soiling of the filter element is not monitored but rather the application-specific "filter service life" defined in the ASD. The filter service life is set to 6 months by default; it can, however, be parameterised system-specifically from 1 to 24 months (see Sec. 9.1 for setting the number of months). After expiry of this filter service life, a "Filter fault (service life exceeded)" is triggered on the ASD. This fault trigger occurs only workdays at 10:00 a.m. (Monday to Friday, provided the time and date are correctly set) and can be reset once. After a waiting time of 14 days, another fault is triggered that can be reset only by replacing the filter element.

The "Filter replacement" function must be activated on the ASD in order to replace the filter element. The options for this are listed below. When filter replacement is activated, the aspirating smoke detector is set to the "Isolate" state. This insures that during the replacement work falling dust particles from the filter element do not cause a false alarm. After the filter has been replaced, the "Filter replacement" procedure is completed by pressing the "Reset" key on the ASD. This cancels the "Isolate" state and resets the fault on the ASD. "Filter service life" monitoring is restarted at 0.

The following filter monitoring operations are available on the ASD 533 (per channel/smoke sensor or together):

- Filter monitoring On/Off;
- Change filter service life (in months, 1 – 24);
- Read out filter service life (configured and expired);
- Activate (start) filter replacement via *EasyConfig*;
- Activate (start) filter replacement by pressing the "Reset" key longer than 15 s (simultaneously for both channels/smoke sensors, provided the channel-based filter monitoring and the "Reset" key are activated);
- Finish filter replacement by pressing the "Reset" key again, or via "ASD Config" > "Filter replaced" or "Deactivate isolation".

The functions can be accessed directly on the ASD via *EasyConfig* operation (switch position **d**) or via the "ASD Config" programming software.

## 3 Design

### 3.1 Mechanical design

The ASD 533 aspirating smoke detector consists of the detector housing and one or two sampling pipe tube networks. The sampling pipes are made of hard PVC or ABS tubes with an external diameter of 25 mm and an internal diameter of 20 mm (see also Sec. 5.3). In special applications – e.g. extremely corrosive environment – other tube materials can also be used, subject to the specifications set out in Sec. 5.3. The sampling pipes have several sampling holes whose size is such that each hole extracts the same amount of air. The sampling pipes may be I-, U-, T-, H-, or E-shaped. The sampling pipes are usually symmetrically designed. Asymmetrical sampling pipe tube networks can also be implemented using the “ASD PipeFlow” calculation software.

The housing cover on the detector housing is opened by means of four rotary snap locks. The middle area of the lower part of the detector housing has two additional mounting points for the rotary snap locks so that the housing cover can be re-fastened for commissioning and maintenance work when the device is open.

Integrated in the detector housing is a fan which, in conjunction with the sampling pipes, ensures an uninterrupted supply of air to the detector housing. Airflow monitoring detects any pipe blockage and pipe breakage per tube network in the sampling pipe.

The detector housing has two chambers with permanently installed SSD 533 smoke sensors. These can be removed for maintenance work in accordance with Sec. 6.3. The air channel through the smoke sensor and fan are separated from the other parts inside the detector housing; this means the ASD 533 is able to remain fully operational during commissioning and maintenance work even when the housing cover is open. Smoke sensor chamber II in the ASD 533-1 is detached so that only the air channel for smoke sensor I is active.

The AMB 33 Main Board contains the processor-controlled evaluation electronics and the connection technology. There are four slots in the detector housing for fitting optional additional modules (XLM 35, ML-SFD, SLM 35, RIM 35, MCM 35, SIM 35, UIM 35).

The housing cover on the detector housing contains the BCB 35 printed circuit board. Pre-defined labelling strips are used for labelling the control unit. If the device is mounted in a position rotated by 180°, the labelling strip can be turned accordingly.



#### Notice

Additional modules XLM 35, ML-SFD, SLM 35, RIM 35, MCM 35, SIM 35 and UIM 35 are available as an option and are fitted to the ASD 533 when setting up the system. A maximum of four modules can be fitted.

Bottom part of detector box

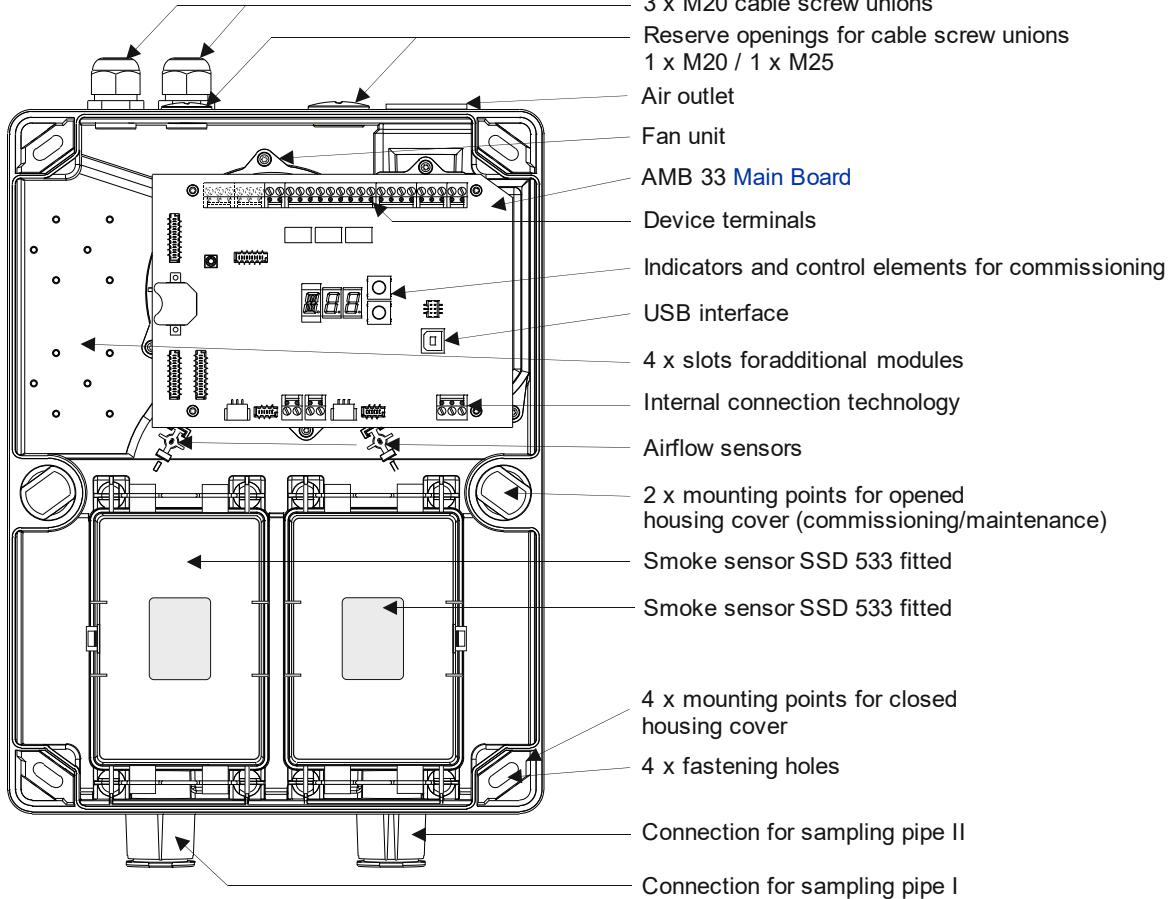

Housing cover

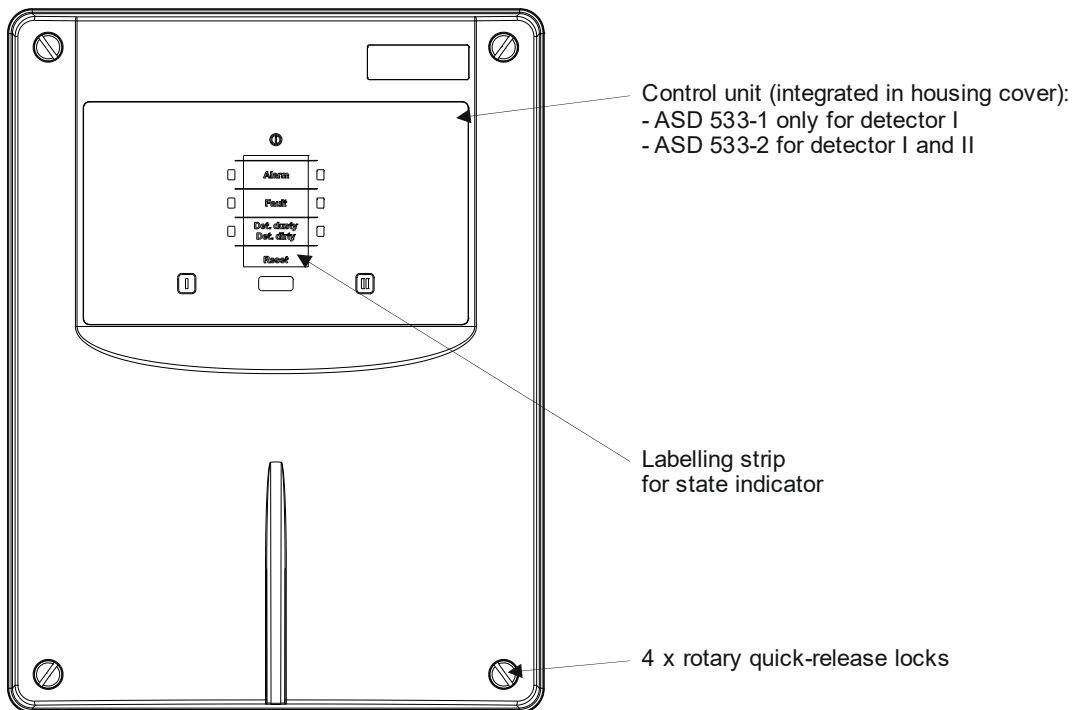

Fig. 4 Mechanical design

## 3.2 Electrical

The electrical design of the ASD 533 comprises the following:

- AMB 33 main board
- BCB 35 printed circuit board integrated in the housing cover
- Smoke sensor I and II (SSD 533)
- Fan
- Air Flow Sensor I, II
- Additional modules XLM 35, ML-SFD, SLM 35, RIM 35, MCM 35, SIM 35, UIM 35.

The following circuit components and elements are to be found on the AMB 33 main board:

- Power supply unit with switching controller
- Fan control with airflow evaluation and temperature measurement
- Smoke sensor evaluation
- 2 opto-isolator inputs for receiving optional smoke detector states (OEM1)
- Opto-isolator input for external reset
- Driver modules for actuating the relays and open collector outputs
- Microcontroller with ports, RAM, Flash PROM, EEPROM, etc.
- Lithium battery
- RTC clock component
- Two pushbuttons, one alphanumeric and two 7-segment displays for configuration setting
- Three relays with potential-free changeover contacts for fault, alarm I, alarm II
- Terminal blocks with pluggable screw terminals for the device connection
- USB interface (device)
- Two LEDs for USB signal (RX [receiver] / TX [transmitter])
- LED for hardware watchdog
- 10-pin ribbon cable connector for connecting to the control unit
- Two 16-pin ribbon cable connector ([Option1](#) and [Option2](#)) for connecting to the XLM 35, ML-SFD ([Option1](#) only), SLM 35, MCM 35, SIM 35, UIM 35
- 1 14-pin ribbon cable connector ([Option3](#)) for connecting to two RIM 35 and MCM 35 (cascaded)
- 1 (2) 6-pin ribbon cable connector for smoke sensor(s)
- 1 (2) 3-pin plug for air flow sensor(s)
- Hardware reset key
- S4 switch for the firmware upgrade

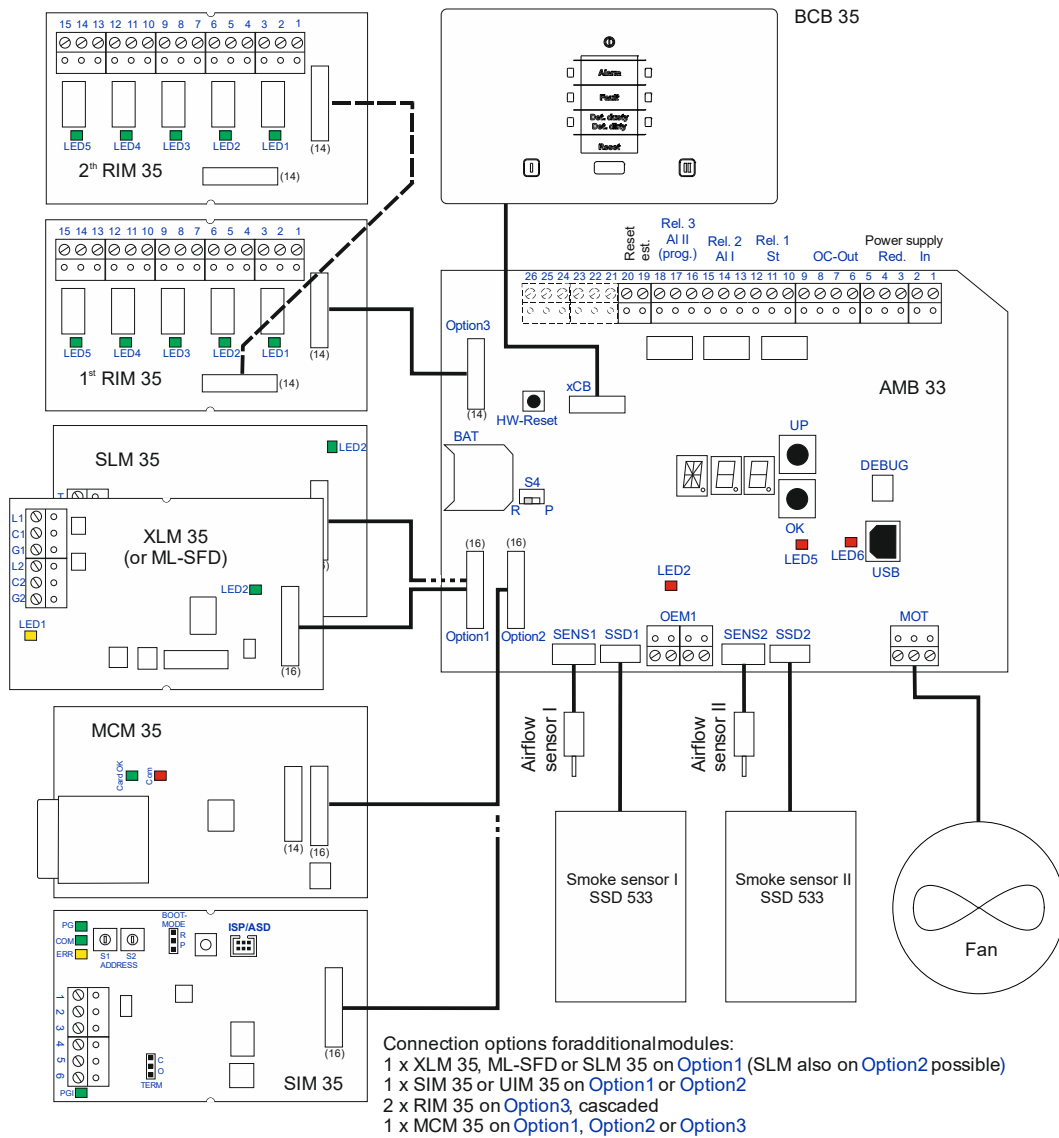

Fig. 5 Electrical design

### 3.3 Hardware / firmware

The hardware is considered to comprise the complete detector housing and all the units belonging to the ASD 533 aspirating smoke detector such as sampling pipe and mounting material.

The firmware is stored on the **Flash** PROM in the ASD 533. An EEPROM is fitted for storing and saving system-specific parameters.

### Notices

- The ASD 533 is to be operated only with the appropriate original firmware from the manufacturer. Any unauthorised intervention on the firmware or the use of non-original firmware may result in malfunction and/or in damage to the device. Furthermore, all guarantee and warranty rights with respect to the manufacturer of the ASD 533 will become null and void as a result.
- We recommend always using the most recent SW version. In the event of changes by the manufacturer to the hardware or software of a product, there is no guaranteed update for existing systems.

### 3.4 List of materials / components

The ASD 533 **ships with** the following equipment (see also Sec. 5.1, 5.3, 9.5.1 and 12):

	AMB 33	Control unit (printed circuit board)	Smoke sensor	Commissioning protocol	XLM / ML-SFD / SLM / RIM / MCM / SIM / UIM
ASD 533-1	yes	BCB 35	1 x SSD 533	yes	-- (accessories)
ASD 533-2	yes	BCB 35	2 x SSD 533	yes	-- (accessories)

The mounting set comprises:

3 x company plates, 1 x M20 blind plug, 4 x S6 dowels, 4 x Torx wood screws (Ø 4.5 x 40 mm), 4 x M4 U-washers (Ø 4.3/12 x 1 mm)

**For the Chinese market:**

- 1 fuse holder with fine fuse 1.6 A for retrofitting in front of supply terminal 1 (+) of the AMB 33
- 2 labelling strips in Chinese language

The following **accessory material** is available:

	XLM 35 / ML-SFD / SLM 35	RIM 35	MCM 35	SIM 35 / UIM 35
ASD 533-1	1 x possible	2 x possible	1 x possible	1 x possible
ASD 533-2	1 x possible	2 x possible	1 x possible	1 x possible

The **material for the sampling pipe** can be purchased separately from the manufacturer in the required quantities, based on the size and use of the system. This material is listed in a separate document; **T 131 194** (see also Sec. 5.3, 9.5.1 and 12).



#### Notice

The material for the sampling pipe is a component of the VdS device approval. Only the materials listed and approved by the manufacturer may be used when setting up the system, see T 131 194. Material from other sources may be used only if the manufacturer's written consent has been obtained.

A special **tool** is required for mounting and handling the ASD 533 (Torx screws). Please refer to the list in Sec. 5.1.

### 3.5 Packaging

The detector housing is delivered in a customised cardboard sleeve sealed with adhesive tape. This packaging is recyclable and can be reused.

The mounting set and installation material sundries are packed in recyclable bags. The sampling tube is supplied in sections (approx. 4–5 m). The flexible tube is supplied in 50 m rolls.

In each case the contents are stated on the package in accordance with Sec. 1.5.



#### Notices

- Electronic components such as printed circuit boards are supplied in antistatic protective packaging. These components should be removed from the packaging just shortly before use or mounting.
- Only devices with unbroken or unopened seals (adhesive tape seal) are considered new. Packaging should not be opened until immediately before use.
- The cardboard packaging of the detector housing meets the minimum requirements for packaging and can be stacked up to 10 times its weight.
- The packaging of the ASD 533 is suitable only to a limited extent for shipment by post or railway.
- For transport in or to tropical regions, marine transport, etc., the appropriate measures must be taken (special packaging as provided by the shipper).

# 4 Planning

## 4.1 General aspects of planning

### 4.1.1 Standards, regulations, guidelines, approvals

Section 4 "Planning" below is a guideline for planning the ASD 533 aspirating smoke detector. These guidelines address the direct application only insofar as it applies to compliance with EN 54-20 and is required to ensure technically trouble-free operation.



#### Notices

- The use of special fire alarm systems such as the ASD 533 is subject in some cases to country-specific regulations and guidelines and must therefore be approved by the relevant technical bodies and authorities (insurance companies) prior to implementation.
- Planning guidelines, application examples and applicable regulations and directives exist for many country-, system- and application-specific applications.
- These documents can be requested from the manufacturer of the ASD 533 system or from the relevant technical bodies and authorities.
- The country-specific regulations and guidelines apply as a matter of principle to the intended use, planning and application of the ASD 533 aspirating smoke detector. In any case the country-specific specifications always take precedence over the planning specifications outlined below.

The ASD 533 aspirating smoke detector complies with the requirements of European Standard EN 54-20, Class A to C. The following applies:

- EN 54-20, Class A           high sensitive
- EN 54-20, Class B       sensitive
- EN 54-20, Class C       standard

## 4.2 Area of application

To comply with a required system configuration, the ASD 533 can be connected to all conventional fire alarm systems virtually without limit via its potential-free changeover contacts or by using control-panel-specific line modules (e.g. XLM 35 / ML-SFD / SLM 35). The following factors determine which system configuration is best suited and should be used:

- Laws, regulations, guidelines;
- Customer requirements;
- System type and area of application;
- Circumstances specific to the building;
- New system, replacement of an existing system, expansion;
- Cost/benefit ratio

### 4.2.1 System limits

The use of an ASD 533 aspirating smoke detector is subject to the system limits listed below and compliance with EN 54-20 requirements. Depending on the planning process, the system limits as set out in Sec. 4.4 and 4.5 **also** apply.

	Class A	Class B	Class C
max. overall length of the sampling pipe tube network per smoke sensor (incl. any air recirculation)	200 m	200 m	200 m
max. length from ASD to farthest sampling hole	80 m	80 m	80 m
max. number of sampling holes per smoke sensor	16	50	50

### 4.2.2 Usable accessory materials for the sampling pipe

Depending on the selected planning method – *with “ASD PipeFlow” calculation* according to Sec. 4.3.1 or *without “ASD PipeFlow” calculation* according to Sec. 4.3.2 – the following accessory materials can be used for the sampling pipe (a complete list of approved materials for the sampling pipe is provided in document T 131 194):

ASD 533		
↳ Planning →	without “ASD PipeFlow”	with “ASD PipeFlow”
↳ Configuration via →	EasyConfig or “ASD Config”	“ASD Config”
<b>Filter</b>		
FBS 25 PC (use only below 0°C)	✓	✓
DFU 911	✓	✓
<b>Dust trap box / dust retaining box / water retaining box</b>		
DTB 25 PC	✗	✓
DRB 25	✗	✓
WR 25 / WRB 25	✓	✓
<b>Capillary sampling tube</b>		
TU 6 PVC	✗	✓
<b>Heating accessories</b>		
All heating accessories	✗	✗
<b>Detonation flame arrester</b>		
DFA 25-1 / DFA 25-2 / DFA 25-3	✗	✗
<b>Automatic blow-out devices</b>		
ADB 1000 / ADB 2000	✗	✓
ADB 500 (no VdS approval)	✗	✓
<b>Detector box</b>		
REK 511	✓	✓



### 4.3.2 Planning without “ASD PipeFlow” calculation

If planning work is carried out without “ASD PipeFlow”, the ASD 533 provides a number of switch positions under which predefined values required for a trigger in accordance with EN 54-20; Class A-C have been stored (see also Sec. 4.4.4.3).



#### Notices: Planning without “ASD PipeFlow” calculation

- The sampling pipe tube network is to be laid out symmetrically as a matter of principle (including sampling holes). Any deviation in symmetry must not exceed  $\pm 10\%$ .
- The maximum tube lengths and number of sampling holes specified in Sec. 4.4.4.3 must not be exceeded.
- Only the tube materials listed in document T 131 194 with a diameter of 25 mm are to be used (including flexible hose).
- A **maximum of two 90° angles** are to be used per sampling pipe. Any other changes of direction that may be necessary in the sampling pipe are to be implemented with 90° bends.
- The maximum number of accessory parts to be used per tube network is as follows:
  - ⇒ one DFU 911 dust filter unit and two detector boxes (REK), individually or combined
  - ⇒ one DFU 911 dust filter unit and one water retaining box (WRB), always in combination, but without detector boxes (REK).
- When using other tube and accessory parts (e.g. more than two 90° angles, flexible tubes, dirt trap boxes), it is imperative that you use the “ASD PipeFlow” calculation software.
- The “ASD PipeFlow” calculation software must be used when planning equipment monitoring.
- The “ASD PipeFlow” calculation software must also be used in applications with air recirculation.

## 4.4 Space surveillance

### 4.4.1 Space surveillance applications

The ASD 533 aspirating smoke detector can also be used for the following applications:

- Spaces where point detectors are difficult to mount due to poor accessibility, e.g.:
  - cable galleries, cable tunnels, false ceilings, hollow floors
  - machine halls, production halls
  - low and high voltage rooms
  - computer rooms, clean rooms
- Spaces where, for aesthetic reasons, point detectors should not be mounted, e.g.:
  - protection of cultural assets
  - museums
- Spaces where point detectors could be damaged, e.g.:
  - prison cells
  - public passageways
- Spaces with localised smoke development, e.g.:
  - warehouses with diesel forklifts
- Spaces with a high level of dust pollution and/or high atmospheric humidity.



#### Notice

Applications with a high level of dust and/or high atmospheric humidity require the use of accessory parts as recommended by the manufacturer, e.g.: dust filter unit, dirt trap box, water retaining box or three-way tap for sporadic cleaning of the sampling pipe with compressed air (see also Sec. 5.5.12).

### 4.4.2 Principles of space surveillance



#### Notices

The following principles apply to space monitoring:

- The number and arrangement of the ASD 533 units are based on the size of the space.
- In general the monitoring areas are the same as for point-type detectors. Any guidelines that apply specifically to particular objects or premises are to be observed.
- The sampling pipe tube networks are to be laid out in such a way that any anticipated fire is detected in its initial stages.
- The aspirating smoke detectors should be positioned in such a way that false alarms are avoided.
- When planning **without** "ASD PipeFlow" calculation, make sure the sampling pipe tube networks are laid out symmetrically (including sampling holes). Any deviation in symmetry must not exceed  $\pm 10\%$ .
- When planning **without** "ASD PipeFlow" calculation, the maximum tube lengths and number of sampling holes specified in Sec. 4.4.4.3 must **not** be exceeded.
- $90^\circ$  bends are to be used instead of  $90^\circ$  angles for any changes in direction. An excessively high number of direction changes significantly affects detection time.
- When planning **without** "ASD PipeFlow" calculation, do not use more than **a maximum of two  $90^\circ$  angles** per sampling pipe. Any other changes of direction that may be necessary in the sampling pipe are to be implemented with  $90^\circ$  bends.
- The minimum limit for the sampling pipe tube length for all applications is **1 m**.
- Several rooms may be monitored by one and the same aspirating smoke detector only if so permitted by the relevant guideline (e.g. DIN VDE 0833-2 in Germany, [VKF](#) in Switzerland).
- The two sampling pipes (I and II) may monitor different areas only if they are located in the same climate zone. Country-specific guidelines must be observed in this case (e.g. DIN VDE 0833-2 in Germany; [VKF](#) in Switzerland).
- Most national application guidelines specify maximum heights for room monitoring of high rooms. If no limits are present, the limits in "FIA Code of Practice" Table 3 can be applied.

### 4.4.3 Types of sampling pipe layouts for space surveillance

Typical layout types for space surveillance are I-shaped, U-shaped, T-shaped, H-shaped and E-shaped sampling pipe tube networks. Other arbitrary forms of sampling pipe layout can also be planned using the “ASD PipeFlow” calculation software (Fig. 7).

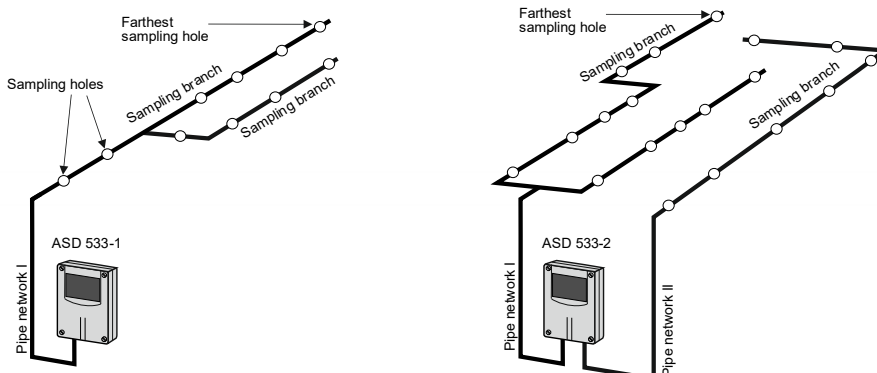

Fig. 7 Examples of planning with “ASD PipeFlow” calculation

If planning **without** “ASD PipeFlow” calculation, make sure the sampling pipe tube networks are set up symmetrically (max. symmetry deviation of  $\pm 10\%$ ). This applies to the tube layout and the spacing between the sampling holes (Fig. 8).

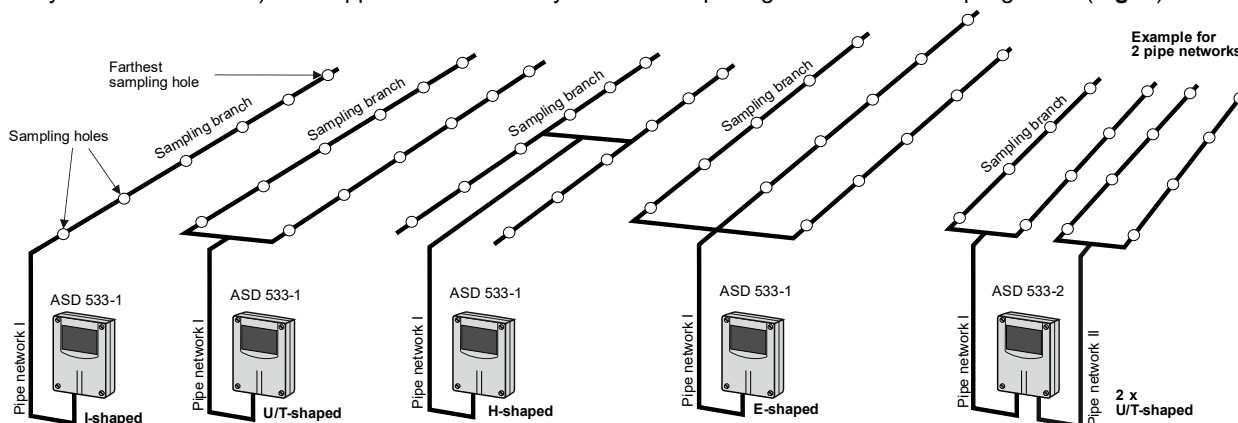

Fig. 8 Examples of planning without “ASD PipeFlow” calculation

## 4.4.4 System limits for space surveillance without “ASD PipeFlow” calculation

The system limits specified in this section apply to planning without using the “ASD PipeFlow” calculation software. Stored under the system limits are switch positions with pre-defined values. There are two areas, with the following meaning:

- Normative system limits according to EN 54-20, Class A to C, switch positions **A11** to **C32**;
- Non-normative system limits, switch positions **W01** to **W48**.

**Fig. 9** below illustrates the possible sampling pipe tube networks with definitions of tube length specifications. The maximum tube lengths and number of sampling holes can be found in the tables in Sec. 4.4.4.3, based on the response grades.

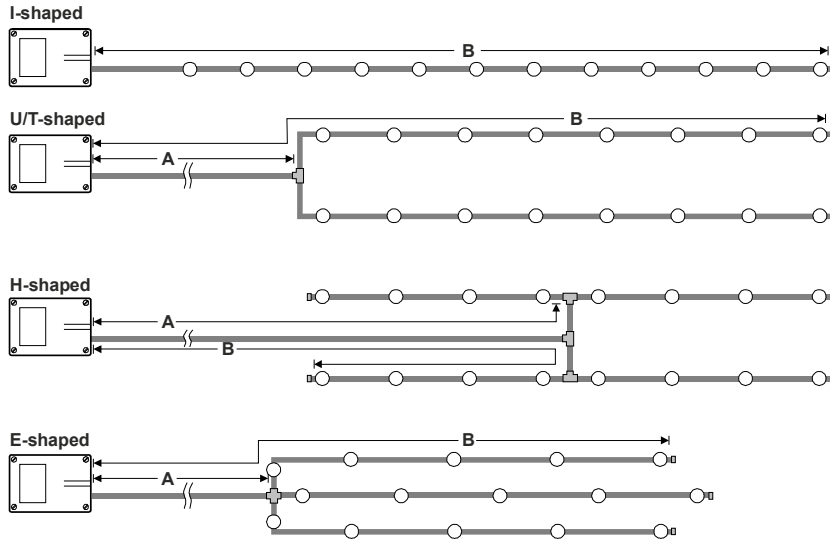

**Fig. 9 Sampling pipe definitions**

### 4.4.4.1 Normative system limits for space surveillance without “ASD PipeFlow” calculation

Stored under switch positions **A11** to **C32** are values which are necessary in terms of alarm response sensitivity and airflow monitoring for compliance with EN 54-20 Class A to C. The switch position designation is deciphered as follows:

- First digit Response grade **A, b, C** (A = highly sensitive, b = sensitive, C = standard)
- Second digit System limit **1, 2, 3** (tube network length, number of sampling holes)
- Third digit Tube networks **1, 2** (number of sampling pipe tube networks on the ASD 533)

Example: **b21** Response grade **b** / system limit **2** / **1** sampling pipe tube network.

### 4.4.4.2 Non-normative system limits for space surveillance without “ASD PipeFlow” calculation

Switch positions **W01** to **W48** contain system limits which fulfil only the alarm response sensitivity compliant with EN 54-20 Class A to C, but not the normative limits concerning airflow monitoring. As they are identical with the system limits **A11** to **C32** in terms of tube topology (tube network length, number of sampling holes), the switch positions **W01** to **W48** are also included in the tables Sec. 4.4.4.3 below. For more details of switch positions **W01** to **W48** concerning number of tube networks and airflow monitoring, please refer to Sec. 4.4.4.4.



#### Notice

Switch positions **W01** to **W48** are to be used only after prior consultation with the manufacturer. The airflow monitoring values stored under those switch positions are not tested in accordance with EN.

4.4.4.3 Table of system limits for planning without “ASD PipeFlow” calculation

Compliant with EN 54-20, Class A (highly sensitive)

Shape	System limit	Switch position compliant with EN 54-20		Switch position non-norm compliant 		Alarm threshold (%/m)	Distance from ASD to last T-piece/cross	Max. length from ASD to the farthest sampling hole	Number of sampling holes per sampling branch	Max. total length of the sampling pipe per tube network (smoke sensor)
		1 tube	2 tubes	1 tube	2 tubes					
I	1	A11	A12	W01 – W04	W05 – W08	0.03	---	50 m	1 – 7	50 m
U / T	1	A11	A12	W01 – W04	W05 – W08	0.03	1 – 20 m	40 m	1 – 4	80 m
H	1	A11	A12	W01 – W04	W05 – W08	0.03	1 – 20 m	40 m	1 – 2	160 m
E	1	A11	A12	W01 – W04	W05 – W08	0.03	1 – 20 m	40 m	1 – 3	120 m

Compliant with EN 54-20, Class B (sensitive)

Shape	System limit	Switch position compliant with EN 54-20		Switch position non-norm compliant 		Alarm threshold (%/m)	Distance from ASD to last T-piece/cross	Max. length from ASD to the farthest sampling hole	Number of sampling holes per sampling branch	Max. total length of the sampling pipe per tube network (smoke sensor)
		1 tube	2 tubes	1 tube	2 tubes					
I	1	b11	b12	W09 – W12	W13 – W16	0.09	---	50 m	1 – 7	50 m
	2	b21	b22	W17 – W20	W21 – W24	0.06	---	70 m	5 – 9	70 m
U / T	1	b11	b12	W09 – W12	W13 – W16	0.09	1 – 20 m	40 m	1 – 3	80 m
	2	b21	b22	W17 – W20	W21 – W24	0.06	1 – 20 m	55 m	3 – 5	110 m
H	1	b11	b12	W09 – W12	W13 – W16	0.09	1 – 20 m	35 m	1 – 2	140 m
	2	b21	b22	W17 – W20	W21 – W24	0.06	1 – 20 m	45 m	2 – 3	180 m
E	1	b11	b12	W09 – W12	W13 – W16	0.09	1 – 20 m	40 m	1 – 2	120 m
	2	b21	b22	W17 – W20	W21 – W24	0.06	1 – 20 m	50 m	2 – 3	150 m

Compliant with EN 54-20, Class C (standard)

Shape	System limit	Switch position compliant with EN 54-20		Switch position non-norm compliant 		Alarm threshold (%/m)	Distance from ASD to last T-piece/cross	Max. length from ASD to the farthest sampling hole	Number of sampling holes per sampling branch	Max. total length of the sampling pipe per tube network (smoke sensor)
		1 tube	2 tubes	1 tube	2 tubes					
I	1	C11	C12	W25 – W28	W29 – W32	0.8	---	40 m	1 – 5	40 m
	2	C21	C22	W33 – W36	W37 – W40	0.35	---	70 m	3 – 9	70 m
	3	C31	C32	W41 – W44	W45 – W48	0.13	---	80 m	7 – 12	80 m
U / T	1	C11	C12	W25 – W28	W29 – W32	0.8	1 – 20 m	30 m	1 – 3	60 m
	2	C21	C22	W33 – W36	W37 – W40	0.35	1 – 20 m	60 m	3 – 5	120 m
	3	C31	C32	W41 – W44	W45 – W48	0.13	1 – 20 m	70 m	5 – 8	140 m
H	1	C11	C12	W25 – W28	W29 – W32	0.8	1 – 25 m	35 m	1 – 2	140 m
	2	C21	C22	W33 – W36	W37 – W40	0.35	1 – 25 m	45 m	2 – 3	180 m
	3	C31	C32	W41 – W44	W45 – W48	0.13	1 – 25 m	50 m	3 – 4	200 m
E	1	C11	C12	W25 – W28	W29 – W32	0.8	1 – 20 m	30 m	1 – 2	90 m
	2	C21	C22	W33 – W36	W37 – W40	0.35	1 – 20 m	50 m	2 – 3	150 m
	3	C31	C32	W41 – W44	W45 – W48	0.13	1 – 20 m	55 m	3 – 5	165 m



Notices

- Switch positions **W01** to **W48** are to be used only after prior consultation with the manufacturer. The airflow monitoring values stored under store switch positions are **not** tested in accordance with EN (see Sec. 4.4.4.4).
- The diameter of the sampling holes is specified in the tables in Sec. 4.4.4.5.
- Physically the sampling holes are to be spaced so that the resulting monitoring areas comply with country-specific guidelines.
- The overall length of the sampling pipe must not exceed the system limits as set out in Sec. 4.2.1.
- The specifications apply to one and two tube networks. Tube inputs I and II are allocated, both symmetrically and identically laid out (deviation ±10%; also applies to the distance between sampling holes).
- The specifications apply with and without detector box (REK, maximum two units), DFU 911 dust filter unit, and water retaining box (WRB). See Sec. 4.3.2 for details of equipping and combining these accessory parts.
- Dust filter unit and water retaining box must always be mounted within the first 2 m of the ASD 533.

## 4.4.4.4 Non-normative system limits table for planning without “ASD PipeFlow” calculation

The table below shows the parameters for switch positions **W01** to **W48** which do not conform to norm EN 54-20 with regard to airflow monitoring. It also shows the number of tube networks for these switch settings. The tube topology specifications (tube network length, number of sampling holes) are shown in the tables in Sec. 4.4.4.3.

Alarm triggering according to EN 54-20		System limit	Number of tube networks	Airflow monitoring		Switch setting
				Delay time	Deviation	
highly sensitive	A	1	1	10 min	± 20%	W01
	A	1	1	60 min	± 20%	W02
	A	1	1	10 min	± 50%	W03
	A	1	1	60 min	± 50%	W04
	A	1	2	10 min	± 20%	W05
	A	1	2	60 min	± 20%	W06
	A	1	2	10 min	± 50%	W07
	A	1	2	60 min	± 50%	W08
sensitive	B	1	1	10 min	± 20%	W09
	B	1	1	60 min	± 20%	W10
	B	1	1	10 min	± 50%	W11
	B	1	1	60 min	± 50%	W12
	B	1	2	10 min	± 20%	W13
	B	1	2	60 min	± 20%	W14
	B	1	2	10 min	± 50%	W15
	B	1	2	60 min	± 50%	W16
	B	2	1	10 min	± 20%	W17
	B	2	1	60 min	± 20%	W18
	B	2	1	10 min	± 50%	W19
	B	2	1	60 min	± 50%	W20
	B	2	2	10 min	± 20%	W21
	B	2	2	60 min	± 20%	W22
	B	2	2	10 min	± 50%	W23
	B	2	2	60 min	± 50%	W24
Normal	C	1	1	10 min	± 20%	W25
	C	1	1	60 min	± 20%	W26
	C	1	1	10 min	± 50%	W27
	C	1	1	60 min	± 50%	W28
	C	1	2	10 min	± 20%	W29
	C	1	2	60 min	± 20%	W30
	C	1	2	10 min	± 50%	W31
	C	1	2	60 min	± 50%	W32
	C	2	1	10 min	± 20%	W33
	C	2	1	60 min	± 20%	W34
	C	2	1	10 min	± 50%	W35
	C	2	1	60 min	± 50%	W36
	C	2	2	10 min	± 20%	W37
	C	2	2	60 min	± 20%	W38
	C	2	2	10 min	± 50%	W39
	C	2	2	60 min	± 50%	W40
	C	3	1	10 min	± 20%	W41
	C	3	1	60 min	± 20%	W42
	C	3	1	10 min	± 50%	W43
	C	3	1	60 min	± 50%	W44
C	3	2	10 min	± 20%	W45	
C	3	2	60 min	± 20%	W46	
C	3	2	10 min	± 50%	W47	
C	3	2	60 min	± 50%	W48	



### Notice

Switch positions **W01** to **W48** are to be used only after prior consultation with the manufacturer. The airflow monitoring values stored under those switch positions are **not** tested in accordance with EN.

**4.4.4.5 Sampling holes for planning without “ASD PipeFlow” calculation**

To ensure that all the sampling holes take in the same amount of air, the diameter of the sampling hole on the sampling tubes fitted must increase as the distance from the detector housing increases.

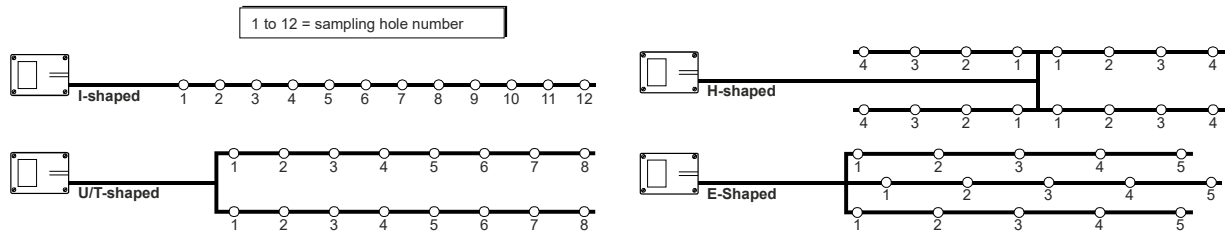

**Fig. 10 Size of sampling holes**

The tables below show the respective hole diameters for the numbers in Fig. 10 as a function of the number of sampling holes per sampling branch (this applies also to high-rack storage facilities).

If required, the sampling holes can be created using the special “sampling hole clips”. The sampling hole clips are available in various sizes (i.e. with hole diameters as indicated in the table above: 2.0 / 2.5 / 3.0 / 3.5 / 4.0 / 4.5 / 5 / 5.5 / 6 / 6.5 / 7 mm). See also Sec. 5.5.9.

I-shaped sampling pipe												
Number of sampling holes in the sampling branch	Hole diameter in mm for the sampling hole number counted from the detector housing:											
	1	2	3	4	5	6	7	8	9	10	11	12
1	5.0											
2	4.0	5.0										
3	4.0	4.0	5.0									
4	3.5	3.5	4.0	5.0								
5	3.5	3.5	3.5	4.0	5.0							
6	2.5	2.5	2.5	2.5	3.0	5.0						
7	2.5	2.5	2.5	2.5	2.5	2.5	5.0					
8	2.5	2.5	2.5	2.5	2.5	2.5	2.5	5.0				
9	2.5	2.5	2.5	2.5	2.5	2.5	2.5	2.5	5.0			
10	2.0	2.0	2.0	2.5	2.5	2.5	2.5	2.5	3.0	7.0		
11	2.0	2.0	2.0	2.0	2.5	2.5	2.5	2.5	2.5	4.0	7.0	
12	2.0	2.0	2.0	2.0	2.0	2.0	2.5	2.5	2.5	2.5	4.0	7.0

U/T-shaped sampling pipe								
Number of sampling holes per sampling branch	Hole diameter in mm for the sampling hole number counted from the detector housing:							
	1	2	3	4	5	6	7	8
1	5.0							
2	4.0	5.0						
3	4.0	4.0	5.0					
4	4.0	4.0	4.0	5.0				
5	4.0	4.0	4.5	5.0	6.5			
6	3.0	3.0	3.5	3.5	4.0	6.5		
7	2.5	3.0	3.0	3.5	3.5	4.0	6.5	
8	2.5	2.5	3.0	3.0	3.5	3.5	3.5	7.0

H/E-shaped sampling pipe					
Number of sampling holes per sampling branch	Hole diameter in mm for the sampling hole number counted from the detector housing:				
	1	2	3	4	5 (E-shaped only)
1	5.0				
2	4.0	5.0			
3	4.0	4.0	5.5		
4	3.0	3.0	3.5	5.5	
5 (E-shaped only)	2.5	3.0	3.0	3.0	6.0

#### 4.4.4.6 Maintenance sampling hole

In applications with sampling holes that are difficult to access, a maintenance sampling hole can, if necessary, be made in the sampling pipe immediately after the detector housing. The maintenance sampling hole must be drilled with a hole diameter of 3.5 mm. The distance from the detector housing must be at least 0.5 m.

If required, the maintenance sampling hole can be made using the special “maintenance clip” (clip without drilling). See also Sec. 5.5.9.

Please note the following information:



#### Notices

When making a maintenance sampling hole, observe the following principles:

- A maintenance sampling hole should be made only if required, for example where normal sampling holes are difficult to access.
- A maintenance sampling hole is not included in the calculations set out in Sec. 4.4.4.3 and 4.4.4.4.
- The maintenance sampling hole is used only for maintenance purposes, to test the ASD 533 for alarming.
- In normal operation (no maintenance), the maintenance sampling hole must be sealed off with adhesive tape or a “maintenance clip” if available.
- All commissioning work on the airflow monitoring (initial reset) must be carried out with the maintenance sampling hole sealed off.

## 4.5 Equipment monitoring

### 4.5.1 Equipment monitoring applications

Equipment monitoring applications using the ASD 533 are additional monitoring applications to space surveillance. Equipment monitoring directly involves monitoring an object (machine, device or equipment). The ASD 533 is capable of monitoring the following objects:

- Electrics cabinets with or without forced ventilation
- EDP computer systems and cabinets with or without ventilation
- Devices and machines in production technology
- Transmitting installations / transmission facilities
- Vacuum cupboards in the chemical industry (air recirculation), subject to prior consultation with the manufacturer.

### 4.5.2 Principles of equipment monitoring



#### Notices

Equipment monitoring is subject to the following principles:

- The country-specific application guidelines must always be adhered to.
- In equipment monitoring it preferable to use Classes A and B compliant with EN 54-20.
- Equipment monitoring applications using the ASD 533 are additional monitoring applications to space surveillance.
- Planning with **the “ASD PipeFlow” calculation software is preferable**. This guarantees optimal detection behaviour and ensures that the technical system limits are optimally utilised. If for any reason the calculation with “ASD PipeFlow” is not possible, the thresholds as set out in Sec. 4.5.4 must be observed.
- Symmetry is not required for equipment monitoring.
- Unlike space monitoring, which involves individual sampling holes, equipment monitoring involves the use of **sampling fixtures** with several sampling holes.
- The **sampling fixture** is defined as a small pipe entity in the shape of an „I“, „U“, „T“, „H“ or other form with typically 2 to 4 sampling holes.
- The sampling fixtures are arranged in such a way relative to the object that they intake the air outflow (ventilation slot or screen). Ideally the sampling holes are distributed symmetrically on each sampling fixture over the surface of the opening / screen.
- On objects with a high air-flow rate (strong ventilation), the sampling holes can be fitted with SF ABS sampling funnels for optimal smoke detection.
- The systems should be formed in such a way that false alarms are avoided.

4.5.3 Examples of sampling pipe layouts for equipment monitoring

Pipe line through hollow floor

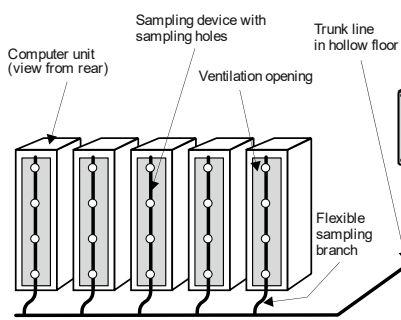

Pipe line through wall or ceiling

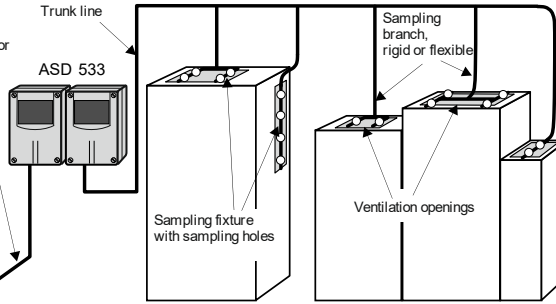

Direct mounting on ventilated EDP cabinets

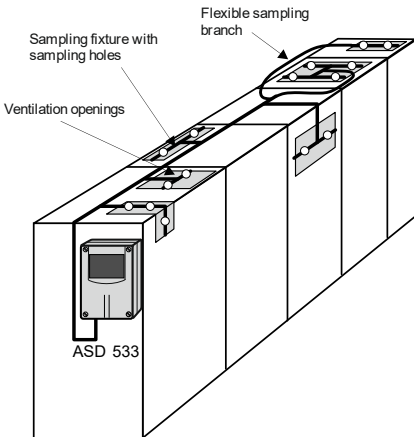

Direct mounting on electric cabinets without ventilation

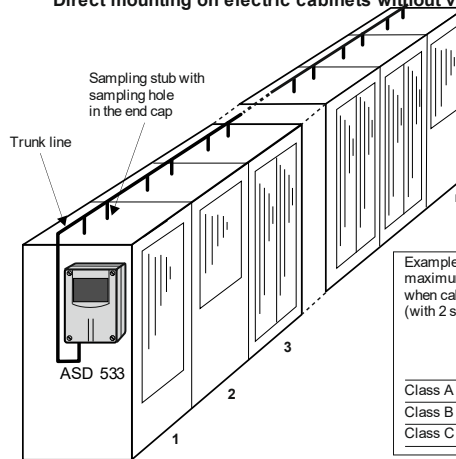

Example:  
maximum possible number of server cabinets  
when calculating with ASD PipeFlow  
(with 2 sampling holes per cabinets ):

	Shape of the sampling pipe:	
	I-shaped (as show)	U/T/H-shaped
Class A	8	8
Class B	15	25
Class C	25	25

Fig. 11 Variants of equipment monitoring layouts (examples)

4.5.4 System limits for equipment monitoring

If it is unavoidable that a project is planned without “ASD PipeFlow” calculation (e.g. system modernisations), the following threshold values must be observed for each pipe input / smoke sensor:

Farthest sampling point	60 m
Minimum length of the sampling pipe	1 m
Maximum length of the sampling pipe (total)	80 m
Tube Ø trunk line (inner/outer)	20 / 25 mm
Minimum tube Ø of flexible sampling branch (inner/outer)	16 / 21 mm
Maximum length per flexible sampling branch	3 m
Number of sampling holes per sampling fixture	2 – 4
Minimum number of sampling holes	4
Maximum number of sampling holes (total)	24



**Notice**

The values in the table above must be strictly observed. Other values may be used only after consulting with the manufacturer.

**4.5.4.1 Alarm thresholds for equipment monitoring using sampling fixtures without “ASD PipeFlow” calculation**

When planning without “ASD PipeFlow” calculation as described in Sec. 4.5.4, the following alarm thresholds (saved on switch positions **X01**, **X02** or **X03**) are to be set by means of the “ASD Config” configuration software based on the total number of sampling holes in **all sampling fixtures (AV)** on the ASD:

**When using without duster filter unit FBL/DFU:**

Response grade	Alarm threshold (%/m) for total number of sampling holes ( <u>without</u> FBL/DFU)					
	4 (1 AV)	5 – 8 (2 AV)	9 – 12 (3 AV)	13 – 16 (4 AV)	17 – 20 (5 AV)	21 – 24 (6 AV)
acc. to EN 54-20, class A	0.1	0.05	0.033	0.024	0.02	---
acc. to EN 54-20, class B	0.29	0.14	0.095	0.07	0.055	0.045
acc. to EN 54-20, class C ①	1.67	0.83	0.55	0.4	0.32	0.25

① In equipment monitoring it preferable to use Classes A and B compliant with EN 54-20.

**When using with duster filter unit FBL/DFU:**

Response grade	Alarm threshold (%/m) for total number of sampling holes ( <u>with</u> FBL/DFU)					
	4 (1 AV)	5 – 8 (2 AV)	9 – 12 (3 AV)	13 – 16 (4 AV)	17 – 20 (5 AV)	21 – 24 (6 AV)
acc. to EN 54-20, class A	0.07	0.035	0.023	---	---	---
acc. to EN 54-20, class B	0.2	0.1	0.065	0.05	0.04	0.03
acc. to EN 54-20, class C ①	1.17	0.58	0.38	0.28	0.22	0.17

① In equipment monitoring it preferable to use Classes A and B compliant with EN 54-20.

## Planning

### 4.5.5 Sampling fixtures and sampling holes in equipment monitoring

The size and number of sampling holes in a **sampling fixture** are based on the size of the object's ventilation slot. The following approximate values apply:

Size of the ventilation slot (length x width in cm)	Shape of the sampling fixture	Number of sampling holes	Hole diameter (mm)
< 20 x < 15	I-shaped	2	According to "ASD PipeFlow" calculation
< 30 x < 15	I-shaped	3	
< 40 x < 15	I- or T-shaped	4	
< 80 x < 20	T-shaped	4	
< 40 x < 40	U-shaped	4	
> 40 x > 40	H-shaped	4	



#### Notices

- The sampling fixtures and their sampling holes must be placed directly in front of the object's airflow.
- The sampling holes must be facing the outflowing air.
- On objects with a high air-flow rate (strong ventilation), the sampling holes should be fitted with SF ABS sampling funnels for optimal smoke detection.
- Symmetry is not required for the sampling fixture.

Below are the system limits for a **direct pipe conveyed** via electrical or server cabinets as shown in **Fig. 11**. Except for the following specified hole diameters in the upper part of the table (e.g. for system modernisations), the hole diameter and alarm threshold are to be specified by an "ASD PipeFlow" calculation:

Electrics cabinet monitoring (acc. to Fig. 11)	Shape of the sampling pipe	Number of sampling holes	Number of cabinets	Hole diameter (mm)
with internal partitions	I-shaped	12	6	4 x 3.5 4 x 4.0 4 x 4.5
without internal partitions	I-shaped	24	12	8 x 3.5 / 8 x 4.0 8 x 4.5 (only class C possible)
acc. to EN 54-20, class A	I-/U-/T-/H- shaped	16	8	or acc. to "ASD PipeFlow" calculation
acc. to EN 54-20, class B	I-shaped	30	15	
	U-/T-/H- shaped	50	25	
acc. to EN 54-20, class C	I-/U-/T-/H- shaped	50	25	

#### 4.6 Two-detector dependency

For 2-detector dependency, systems with two smoke sensors must be used, i.e. ASD 533-2. The layout of the sampling pipe tube network may be single or double. When monitoring with only one tube network, tube inputs I and II merge before entering the detector housing. The two smoke sensors of the ASD 533 must be independently evaluated (see Sec. 6.6.4.1). **Important:** When monitoring **extinguishing areas**, a **dual layout** of the sampling pipe tube network is required. Country-specific guidelines must be observed.

#### 4.7 Air recirculation

In applications where the sampling holes and the detector housing are in different climate zones, the sampled air has to be recirculated back to the climate zone of the sampling holes. It is imperative that the “ASD PipeFlow” calculation software is used to calculate the sampling pipe.

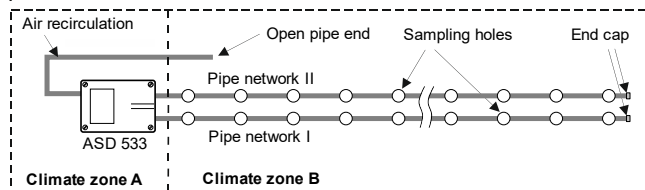

Fig. 12 Air recirculation for differing climate zones

### 4.8 Settings

Depending on the planning process – with or without the “ASD PipeFlow” calculation software – the following setting procedure is required:

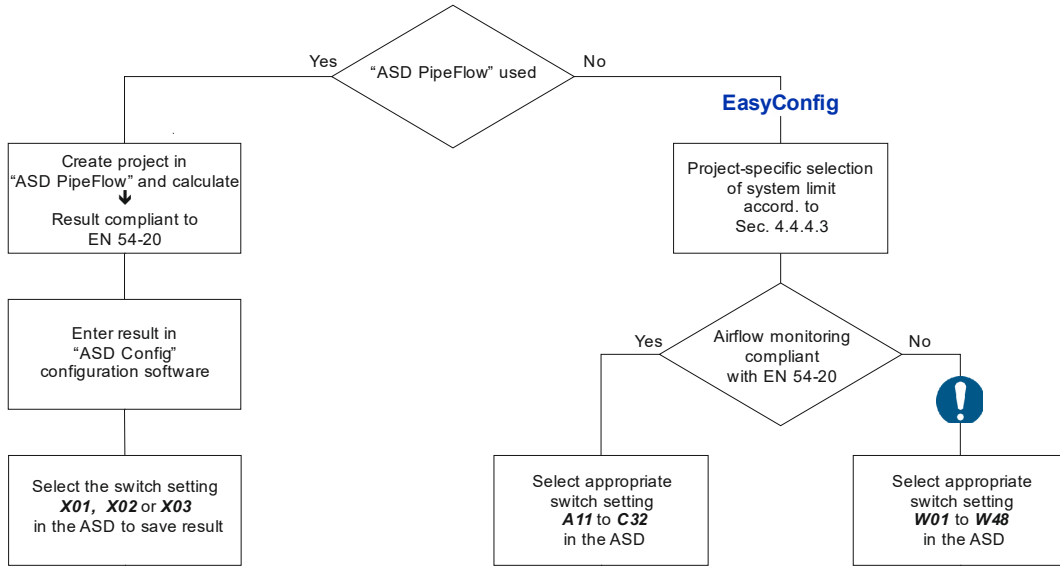

Fig. 13 Workflow for project-specific programming and adjustment



#### Notice

Switch positions **W01** to **W48** are to be used only after prior consultation with the manufacturer. The airflow monitoring values stored under those switch positions are **not** tested in accordance with EN.

The description of the predefined positions and the operator structure can be seen in Sec. 4.4.4.3, 4.4.4.4, 7.2.1 and 8.3.

Depending on the use of the ASD 533, it may be necessary to make adjustments to the airflow monitoring using the “ASD Config” configuration software. These adjustments relate merely to the size of the monitoring window (pipe breakage/pipe blockage) and the fault delay time (time until the exceeded monitoring window is reported as a fault). Please note and adhere to the following information:



#### Notices

- Increasing the LS-Ü values –  $\rightarrow \pm 20\%$  /  $> 300\text{ s}$  – means that norm EN 54-20 is no longer complied with and should only be used after consultation with the manufacturer.
- The **window size  $\pm 20\%$**  should **not be fallen short of** as a matter of principle. Smaller window sizes should only be set if the delay time for the airflow monitoring is increased to at least **10 min** at the same time. Due to the very high sensitivity of the airflow monitoring when the window size is below  $\pm 20\%$  and the delay time is  $\leq 300\text{ s}$ , the risk of false alarms due to airflow monitoring faults increases accordingly.
- In applications with high levels of air turbulence, it may be necessary in some instances to increase the delay time and the window size to over  $\pm 20\%$ . **Important:** This means that norm EN 54-20 is no longer complied with and should only be used after consultation with the manufacturer.
- Changing the “**Airflow pipe blockage / pipe breakage On/Off**” configuration implies use under special conditions and should only be implemented after consulting the manufacturer.

## 4.9 Electrical installation

### 4.9.1 Installation cable requirements

The power supply line from the FACP to the detector housing is defined by the line and FACP technology in use.

Cables with twisted pairs are to be used as a matter of principle. With 4-wire and multi-wire cables, twin- or quad-twist cables are to be used.

Laying the voltage supply line and line in parallel is permitted.

A separate wire pair is to be used for the ASD 533 voltage supply.

The electrical installation is usually performed with commercially available cables. Depending on the country of use, special fire detector cable may be required by the relevant authorities. The relevant country-specific authorities should therefore be consulted about the required cable types.

The installation cable must have a minimum wire diameter of 0.8 mm (0.5 mm<sup>2</sup>). **Please refer to Sec. 4.9.2 to determine the exact maximum cable length and the required cable cross-section.**



#### Notices

- For safety reasons (EN 54) individual cables must be used for the outbound and return lines for addressable loop technologies.
- It is also important **to observe** the **FACP manufacturer's specifications** concerning the maximum **line length, cable type, screening**, etc., of the addressable loop technology used.
- The order separation and installation type are also subject to country-specific guidelines and regulations.
- **Caution, use compliant with UL:** For system monitoring – for terminals “Alarm” and “Fault”, **do not use looped wire** under terminals. Break wire run to provide monitoring of connections.
- The electrical installation of the ASD 533 can normally be performed without screening. The installation of the SecuriFire / Integral addressable loop on an **XLM 35 / ML-SFD** must be **shielded**. Screening of the installation is required wherever EMC influences are to be expected. In the following environments disturbance variables can be expected and the installation must be provided with screening accordingly:
  - In and around transmitter and radio facilities. Near high-voltage and low-voltage installations with high energy. In areas with EMC field intensities in excess of 10 V/m. In cable ducts and vertical shafts together with high-energy cables In areas with high-energy devices and installations (generators, power plants, railway facilities, X-ray equipment, etc.). Outside buildings.
- If screening is used, the cable screening in the ASD 533 is to be connected to an additional support terminal. The cable screening must **not** be connected to the minus or **ground** terminal of the AMB 33.



## 4.10 Limitations



### Notices

The following limitations apply to the use and application of the ASD 533. For other solutions, please consult the manufacturer.

#### General information and space surveillance:

- The sampling holes of both tube networks and the detector housing must be in the same climate zone (pressure/temperature zone) (sampled air may have to be recirculated to the other climate zone). Pressure differences between detector housing and sampling pipe (sampling holes) are not permitted.
- If sampling pipes with air at room temperature have to be routed through areas in which the temperature may drop below 4 °C, the tube parts in these areas may have to be specially installed (possibly by isolating the sampling pipe as specified by the manufacturer).
- Applications with a high level of dust and/or high atmospheric humidity require the use of accessory parts as recommended by the manufacturer, e.g.: dust filter unit, dirt trap box, water retaining box or manual ball valve for sporadic cleaning of the sampling pipe using compressed air (see also Sec. 11).
- The maximum pipe length specified must **not** be exceeded.
- Several rooms may only be monitored by one and the same aspirating smoke detector if so permitted by the relevant guideline (e.g. DIN VDE 0833-2 in Germany, [VKF](#) in Switzerland).
- The two sampling pipes (I and II) may monitor different areas only if they are located in the same climate zone. Country-specific guidelines must be observed in this case (e.g. DIN VDE 0833-2 in Germany; [VKF](#) in Switzerland).
- For space surveillance involving premises with a height of more than 16 m, the situation must first be clarified beforehand with the manufacturer, the insurance companies and, if necessary, the fire brigade (in some cases larger or higher monitoring areas are possible).
- In the event of an emergency the sampling holes must be accessible for cleaning (possibly by cleaning using compressed air from the detector housing or under 0 °C with nitrogen).
- The fan creates a sound pressure level (possibly mount the detector housing in an acoustically insulated cabinet – e.g. ASD sound insulation housing – or ancillary room, see also Sec. 5.4).
- Special settings (larger airflow window, longer delay time, etc.) may have to be made in areas with significant temperature fluctuations of more than 20°C at both the sampling pipe and the detector housing.
- In spaces with high ambient temperatures of > 50°C and/or a humidity of > 80%, cooling sections may have to be used in the sampling pipe.
- Only those materials listed and approved by the manufacturer are to be used to create the system (component of the device approval according to EN 54-20). Materials from other sources may be used only if the manufacturer's written consent has been obtained.
- It is **not** permitted to monitor ex-zones with the ASD 533.
- The environmental influences as listed in Sec. 4.11 must be observed.

#### Equipment monitoring (additional):

See Sec. 4.5

## 4.11 Environmental influences



### Notices

- On the basis of the tests conducted, the ASD 533 may be used in an environment that is within the scope of the type approvals. The environmental conditions as described in Sec. 13 must also be observed. Non-observance can negatively impact the proper functioning of the ASD 533.
- For special applications (e.g. in Arctic or tropical climates, in marine applications, high-level EMC environments, high shock impact, etc.) please contact the manufacturer of the ASD 533 for empirical values and special application guidelines.

## 4.12 Use compliant with UL 268 7<sup>th</sup> Ed and ULC-S529 4<sup>th</sup> Ed

For use compliant with **UL 268 7<sup>th</sup> Ed** and **ULC-S529 4<sup>th</sup> Ed** the following alarm sensitivity ranges of the used smoke sensors in the ASD 533 must be adhered to.



### Notices

- ① All sampling holes in the tube network shall have a calculated sensitivity value and transport time according to the specifications in the following tables. The "ASD PipeFlow" must be used for the calculation.

### 4.12.1 Use in USA according to UL 268 7<sup>th</sup> Ed

For use within the USA, the following information and the listed edition of the UL standard apply:

Special applications, according to UL 268 7 <sup>th</sup> Ed		
Sampling hole sensitivity range ①	0.02 – 0.8 %/m	0.0061 – 0.24 %/ft
Air velocity range	0 – 20 m/s	0 – 4000 ft/min
Maximum transport time ①	57 s	
Sampling holes / sampling tube configuration	as defined by "ASD PipeFlow" calculation software ①	
Open area protection, according to UL 268 7 <sup>th</sup> Ed		
Sampling hole sensitivity range ①	5.14 – 5.92 %/m	1.6 – 1.84 %/ft
Air velocity range	0 – 20 m/s	0 – 4000 ft/min
Maximum transport time ①	5 s	
Sampling holes / sampling tube configuration	as defined by "ASD PipeFlow" calculation software ①	

### 4.12.2 Use in Canada according to ULC-S529 4<sup>th</sup> Ed

For use within Canada, the following information and the listed edition of the ULC standard apply:

Special applications, according to ULC-S529 4 <sup>th</sup> Ed		
Sampling hole sensitivity range ①	0.02 – 10 %/m	0.0061 – 3.16 %/ft
Air velocity range	0 – 20 m/s	0 – 4000 ft/min
Maximum transport time ①	48 s	
Sampling holes / sampling tube configuration	as defined by "ASD PipeFlow" calculation software ①	
Open area protection, according to ULC-S529 4 <sup>th</sup> Ed		
Sampling hole sensitivity range ①	1.63 – 5.96 %/m	0.5 – 1.86 %/ft
Air velocity range	0 – 20 m/s	0 – 4000 ft/min
Maximum transport time ①	48 s	
Sampling holes / sampling tube configuration	as defined by "ASD PipeFlow" calculation software ①	

## 5 Mounting

### 5.1 Mounting guidelines



#### Notices

**Material and products;** only the following materials supplied, approved and listed by the manufacturer may be used to create the system:

- Detector housings, smoke sensors, additional modules;
- Tube materials and fittings for the sampling pipe, accessory materials, pipe clamps (according to T 131 194).

Materials from other sources do not conform to EN 54-20 approval and may only be used if the manufacturer's written consent has been obtained.

Installation materials such as cables, intermediate distributors and fastening materials are usually supplied by the customer.

**Tools for handling the detector housing:** The tools listed below are required for mounting and installation (sorted in the sequence in which they are used in this document):

- |  |                                       |
|--|---------------------------------------|
| • Opening the detector housing                   | flat-blade screwdriver No. 5 (8 mm)   |
| • Removing the pipe plug                         | flat-blade screwdriver No. 2 (4 mm)   |
| • Securing the detector housing                  | Torx screwdriver T20                  |
| • Module holder for additional modules           | Torx screwdriver T15                  |
| • Terminals                                      | flat-blade screwdriver no. 1 (3.5 mm) |
| • Replacing printed circuit boards AMB, ACB, BCB | Torx screwdriver T10                  |
| • Replacing the aspirating fan unit              | Torx screwdriver T15                  |

### 5.2 Dimensioned drawing / drilling plan for the detector housing

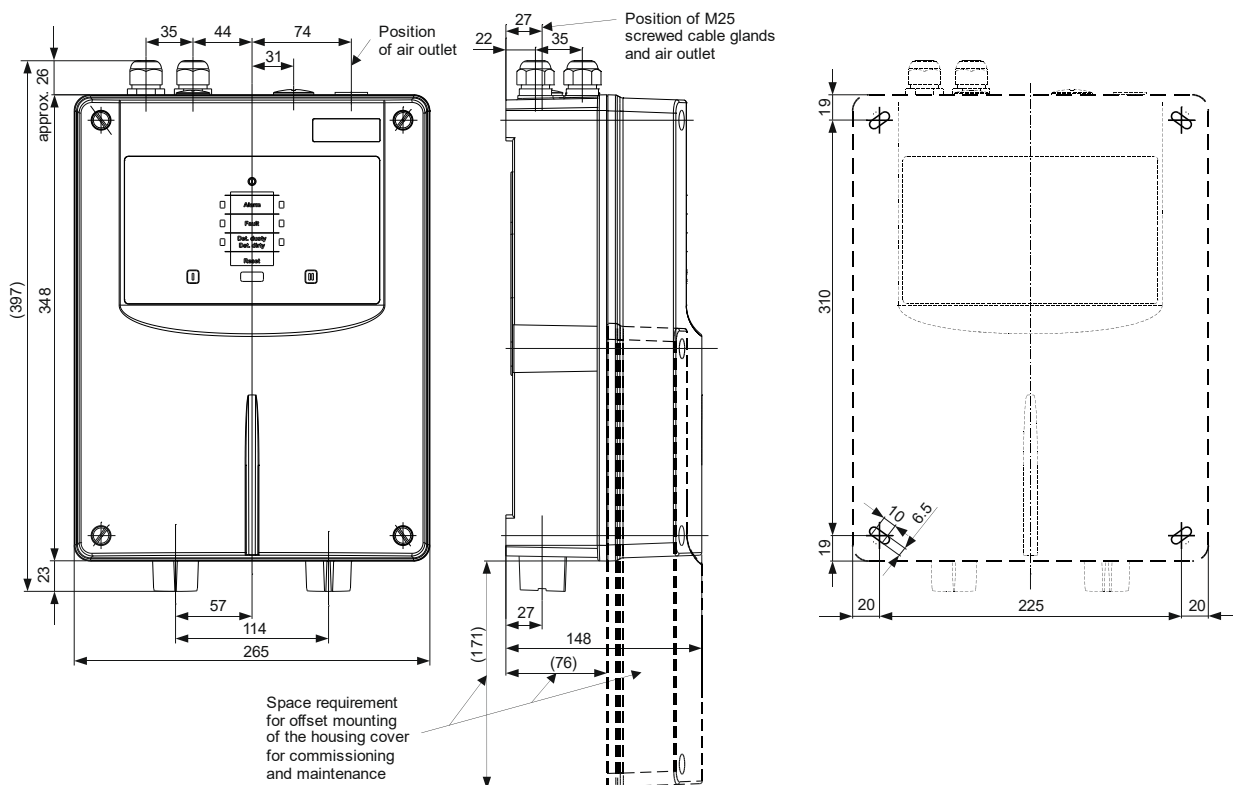

Fig. 14 Detector housing dimensioned drawing and drilling plan

### 5.3 Materials for the sampling pipe



#### Notices

Tube materials and fittings must be rated at least as Class 1131 of norm **EN 61386-1**. The materials listed in document **T 131 194** satisfies this standard and is part of the device approval in accordance with EN 54-20 for the ASD 533.

Other materials do not conform to the EN 54-20 standard and may be used only if the manufacturer's written consent has been obtained and the following conditions are met.

- Compression resistance = min. 125 N (EN 61386-1)
- Shock resistance = min. 0.5 kg, fall height of 100 mm (EN 61386-1)
- Temperature range = min. -15°C to +60°C (EN 61386-1)
- Tube inner diameter = 19 to 22 mm
- Bending radius, bend = min. 30 mm.

The tube material is available in various plastics and metals. The individual plastic tube parts are usually glued. The flexible tube material for equipment monitoring is pluggable. The metal tubes are connected by means of press fittings.

The rigid plastic tubes can be shaped by heating. The tubes can be painted a different colour, although attention must be paid to the chemical compatibility between paint and tube.

The following materials are available:

Material	Connection
PVC (polyvinyl chloride, contains halogen)	Gluing
ABS (acrylonitrile-butadiene styrene, contains halogen)	Gluing
PA (polyamide, contains no halogen)	Plug-in connection
Copper	Press fitting
Stainless steel	Press fitting



#### Notices (see also Sec. 9.5.1)

- The two materials that use adhesives (PVC and ABS) must not be combined as different adhesives are used.
- Transitions from PVC or ABS to PA materials (flexible tube parts) are possible using special adhesive-screw junctions.
- As a material, PVC releases corrosive and toxic gases if burned or improperly disposed of. The use of PVC materials should therefore be restricted to wherever it is expressly permitted by the operator of the installation. In applications stipulated the use of halogen-free plastics, ABS or PA materials must be used for laying the sampling pipe. Country-specific guidelines and regulations must be observed.
- The adhesives and cleaning agents used for connecting PVC and ABS materials contain solvents and are combustible. For this reason, prior to working with these materials it is imperative to read and observe the safety instructions and information provided by the adhesive supplier.

The **sampling pipe materials** (tubes, fittings, etc.) available for the ASD 533 is listed in a separate document; **T 131 194**.

## 5.4 Mounting the detector housing



### Notices

- Mounting work on the detector housing is best carried out without the smoke sensors fitted.
- The smoke sensors should only be removed from their protective packaging and definitively inserted in the detector housing when commissioning the ASD 533 (see also Sec. 6.3).
- Depending on the circumstances (e.g. long periods of time between mounting and commissioning or if the environment is extremely dusty (construction work), the housing cover should be kept closed until the device is commissioned.

The detector housing should always be kept in the room to be monitored. If this is not possible, ensure that the detector housing is located in a room that has the same air pressure or – in the case of air-conditioned rooms – the same climate and pressure zone. In applications where the sampling pipe and detector housing are mounted in different climate zones, a return sampling pipe to the monitored area is required. The return line can be adapted after removing the air outlet pipe plug on the ASD 533 housing. See also under Sec. 5.4.2 and 5.4.3.

Special settings (larger airflow window, longer delay time etc.) may have to be made in areas with significant temperature fluctuations of more than 20°C at both the sampling pipe and on the detector housing. This also applies to temperature differences of more than 20°C between sampling pipe and detector housing.

An easily accessible installation location should be chosen so that the detector housing can be worked on without aids such as ladders and scaffolding. The ideal installation height for the detector housing is about 1.6 m above ground level (top edge of the detector housing).

On the entry side of the sampling pipe maintain a minimum distance of 20 cm from any structural elements (see also **Fig. 14**) so that the housing cover can be secured in an offset position (commissioning and maintenance). A distance of 10 cm is sufficient on the entry side of the supply cables.

When positioning the detector housing, take into account the fact that the noise caused by the fan may in some cases be perceived as a disturbance. If no suitable location is available for the detector housing, it may be necessary to mount it in a sound insulated cabinet (e.g. ASD sound insulation housing). If air recirculation back to the same climate zone as the sampling pipe is necessary, it can be implemented using a tube piece out of the sound insulated cabinet. The tube piece exiting from the sound insulated cabinet (transition) must be properly sealed. When using the ASD sound insulation housing, an M32 cable screw union is used for the transition. For further details about the ASD sound insulation housing contact the manufacturer.

## 5.4.1 Opening and closing the detector housing



### Notices about opening and closing

- To open the detector box, use a **flat-blade screwdriver no. 5** (8 mm). Smaller flat-blade screwdrivers may damage the material of the rotary snap locks.
- To actuate the **rotary snap locks**, **press** them **firmly** with the screwdriver towards the housing base and then **turn** through 90°. The position of the lock slit shows the current status (see **Fig. 15**):
  - ⇒ approx. 45° angled toward detector housing corner = closed;
  - ⇒ approx. 45° angled toward detector housing edge = open.
 In either position the rotary snap locks **must** snap into place.
- The **housing cover** (control unit) is connected to the main board by a **ribbon cable**. Make sure the ribbon cable is not damaged when the housing cover is lifted away.

### Opening / closing

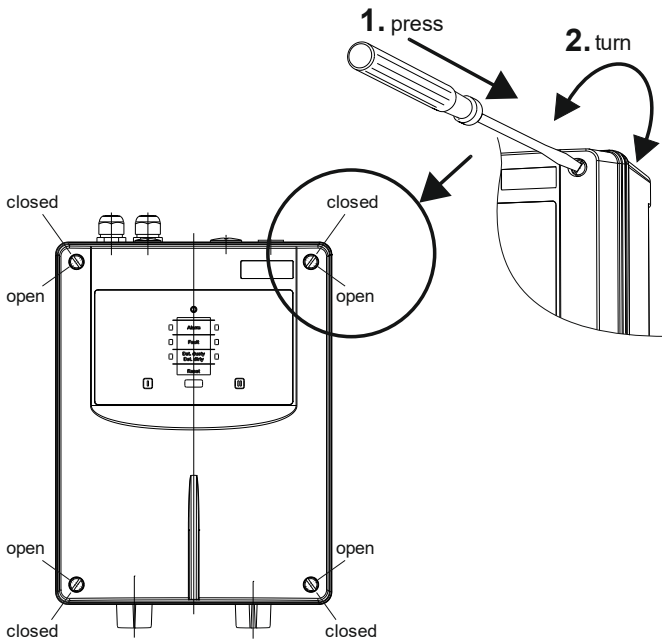

### Locking

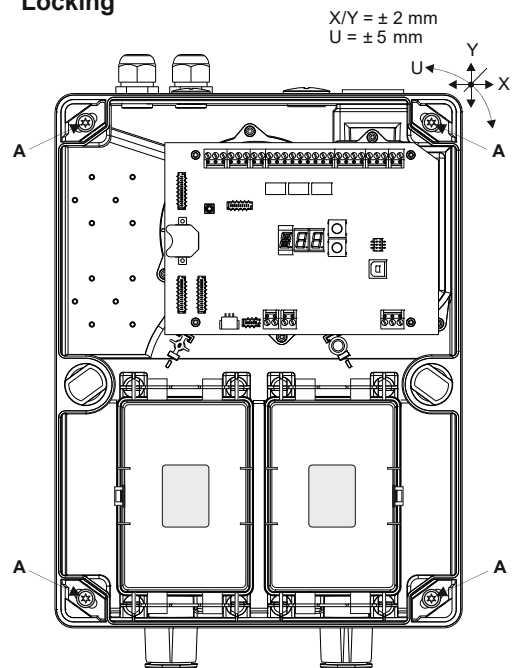

**Fig. 15** Open, closing and securing the detector housing

Once the detector housing is open, the four mounting holes in the housing base are accessible. To facilitate the mounting work, remove the entire housing cover from the detector housing (including the control unit). To do so, unplug the 10-pin ribbon cable connector from the AMB 33 Main Board.

The detector housing is secured using the four supplied Torx wood screws (Ø 4.5 x 35 mm) and the four U-washers (Ø 4.3/12 x 1 mm) "A". Use a **Torx screwdriver T20** to insert and tighten the screws.

The positions of the fastening holes are shown in dimensioned drawing **Fig. 14**. When fastening to masonry, use the S6 dowels supplied.



### Notice

When mounting several ASD 533 units next to one another, make sure that the mounting holes are **drilled precisely**. The device can be shifted by a maximum of ±2 mm horizontally and vertically to correct its mounting position. A rotation correction of approx. ±5 mm is possible.

## 5.4.2 Mounting positions for the detector housing

In principle the detector housing can be mounted in the X, Y or Z axis. However, because of the labelling for the indicator elements, it is advisable to mount the device in the Y axis (vertical, control unit at the top). The sampling pipes are then inserted into the detector housing from below. This makes it easier to feed the tubes to accessory parts such as dust filter unit and water retaining box, which for physical reasons should always be below the ASD detector housing. If feeding the sampling pipes into the detector housing from above is unavoidable, the detector housing can also be rotated through 180° and then mounted (i.e. with the control unit at the bottom). To ensure that control unit labelling is not upside down, turn the control unit labelling strips accordingly (see Sec. 5.4.4).

The allocation of the tube networks on the detector housing is fixed permanently and identified by means of the ribs on each tube input (I and II). To prevent the ingress of dirt, the detector housing ships with the pipe plugs fitted (input tube networks I and II). Likewise all the cable screw unions are sealed. Depending on the device execution, the pipe plug is removed on entry I for (ASD 533-1) and on entry II for (ASD 533-2). For ASD 533-1 with only one tube network, the pipe plug on entry II is not removed. If there is a return sampling pipe back to the monitored area, it can be connected directly to the detector housing in place of the air outlet pipe plug.

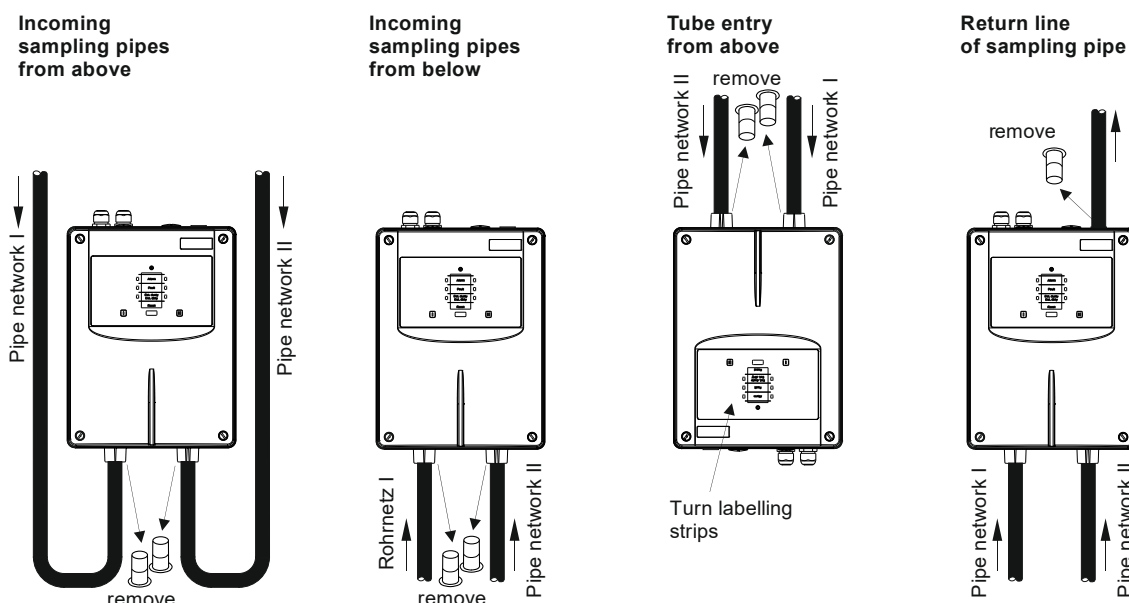

Fig. 16 Mounting position and pipe entries on the detector housing



### Notices about pipe entries

- The entry openings on the detector housing are designed so that the sampling pipe simply has to be plugged into place (conical opening). The sampling pipe should only be glued into place in exceptional circumstances and only after consulting with the manufacturer.
- On the ASD 533-1 the pipe plug must remain on entry II.
- The air outlet pipe plug (with openings) is to be fitted to the air outlet opening only.
- The pipe plugs must not be glued in the ASD housing (plug-in connector).

## Mounting

### 5.4.3 Removing the air outlet pipe plug

Insert the blade of a **flat-blade screwdriver no. 2** (4 mm) into one of the side recesses on the air outlet pipe plug. To release the pipe plug, prise gently toward the ASD housing.

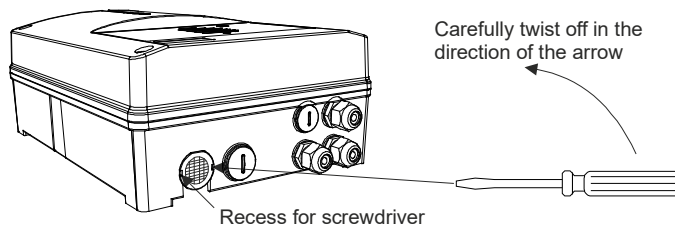

Fig. 17 Removing the air outlet pipe plug

### 5.4.4 Turning the labelling strip

To turn the labelling strip, open the detector housing and remove the cover completely from the device (detach the ribbon cable).

Use the tab to pull the labelling strip out of the control unit, turn it over, and then re-insert it into its compartment.

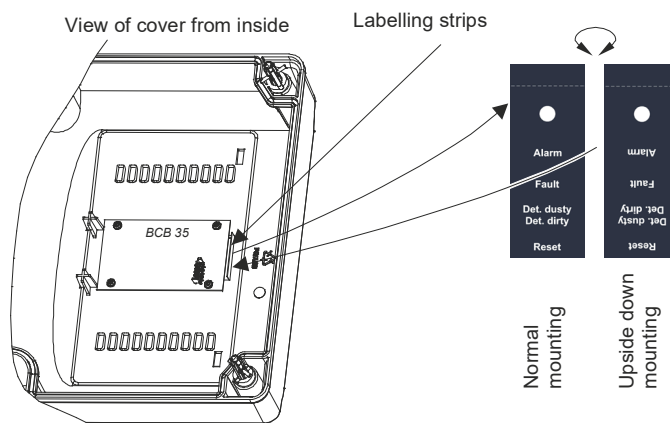

Fig. 18 Turning the labelling strip

## 5.5 Mounting the sampling pipe

### 5.5.1 General

The mounting and installation are to be carried out by analogy with the chapter “Planning” in this document. Any deviation from the layout of the sampling pipe and sampling holes (also outside the limits calculated using “ASD PipeFlow”) is subject to the consent of the manufacturer.

The sampling pipe can be made of hard PVC or halogen-free ABS material, depending on requirements. In special applications – e.g. extremely corrosive environment – other tube materials can also be used, subject to the specifications set out in Sec. 5.3.

### 5.5.2 Mounting with PVC tubes and fittings

As a rule, if the system operator does not specify a halogen-free installation, the sampling pipe can be made using hard PVC tubing. When PVC tube material is installed, the individual tube parts are glued together using a special PVC adhesive (e.g. Tangit for PVC). The adhesive manufacturer’s instructions must be followed. Before gluing, use household paper to remove any dust and grease deposits from the surfaces to be glued (do not use textile cloths). If the tube parts are very dirty, a cleaning agent as specified by the adhesive manufacturer may have to be used.



#### Notices

- The adhesives and cleaning agents used for connecting PVC materials contain solvents and are combustible. For this reason, prior to working with these materials it is imperative to read and observe the safety instructions and information provided by the adhesive supplier.
- The two glueable materials – PVC and ABS – must not be combined, since different adhesives are used.

### 5.5.3 Mounting with ABS tubes and fittings

If required, halogen-free ABS material can be used for the sampling pipe. When ABS tube material is installed, the individual tube parts are glued together with a special ABS adhesive (e.g. Tangit for ABS). The adhesive manufacturer’s instructions must be followed. Before gluing, use household paper to remove any dust and grease deposits from the surfaces to be glued (do not use textile cloths). If the tube parts are very dirty, a cleaning agent as specified by the adhesive manufacturer may have to be used.



#### Notices

- The adhesives and cleaning agents used for connecting ABS materials contain solvents and are combustible. For this reason, prior to working with these materials it is imperative to read and observe the safety instructions and information provided by the adhesive supplier.
- The two glueable materials – ABS and PVC – must not be combined, since different adhesives are used.

### 5.5.4 Mounting with metal pipes and fittings

Metal tubes (copper, stainless steel) are connected using press fittings according to the manufacturer’s instructions. For this purpose, commercially available radial pressing tongs (e.g. REMS radial pressing tongs) with the appropriate V pressing contours can be used.

### 5.5.5 Linear expansion

Plastics have sizeable linear temperature expansion coefficient, which is why special attention should be given to the linear expansion (extension and contraction) of the sampling tube. An increase in temperature causes the tube to expand; a decrease in temperature causes it to contract. The importance of taking linear expansion into account increases as the temperature at the time of installation deviates from the usual operating temperature.

Linear expansion can be calculated as follows:

Calculation:  $\Delta L = L \times \Delta T \times \alpha$

$\Delta L$  = Linear expansion in mm  
 $L$  = Length in metres of the sampling pipe between two fixed points  
 $\Delta T$  = Temperature change in °C  
 $\alpha$  = Linear expansion coefficient in mm/m°C  
for **PVC** = 0.08  
for **ABS** = 0.10

Example: sampling pipe length 20 m, anticipated temperature change 10°C, material PVC:

Calculation:  $\Delta L = 20 \times 10 \times 0.08 = 16 \text{ mm}$



#### Notice

If the sampling pipe is laid in a straight line the linear expansion over the total sampling line length (110 m) within the permissible temperature fluctuation (20°C) can amount to as much as **176 mm**. It is therefore essential to ensure that the sampling pipe is able to “work” (slide) inside the pipe clamps. A distance of 200 mm (0.2 m) must therefore be maintained between the last pipe clamp and the end cap.

5.5.6 Mounting the sampling pipe

**Notice**

When mounting the sampling pipe, make sure the points listed below are noted and observed (see Sec. 5.5.5).

- Pipe clamps at 1 m intervals are used to fasten the sampling pipe.
- The tubes must be cut to size using a pipe cutter. In doing so, ensure that the cut is at a right-angle to the tube axis. Remove any projecting burrs, **Fig. 19**.
- The ends of the individual tube pieces are to be bevelled slightly using a suitable tool, e.g. slightly bevel with a pipe scraper, **Fig. 19**.
- The individual tube sections are connected using fittings. Depending on the tube material used, use either the adhesive process described in Sec. 5.5.2 and 5.5.3 or the pressing process described in Sec. 5.5.4. The tubes are pushed into the fittings as far as the stop, **Fig. 20**.
- The connection points must be sealed tight to prevent the intake of any leakage air.
- If the sampling pipe or parts thereof is laid out vertically (e.g. in a riser or high-rack storage facility), make sure the tubes cannot slide down (fasten pipe clamps directly below the fittings as shown in **Fig. 21**).
- The sampling pipe must be fastened so that the tube is able to “work” within the pipe clamps (linear expansion, see Sec. 5.5.5).
- A distance of at least 0.2 m must be maintained from the T-piece to the pipe clamps, starting from the branching points of the sampling pipe, **Fig. 22**.
- For changes of direction in the space surveillance, it is advisable to use 90° bends rather than 90° angles, **Fig. 22** (see also Sec. 4.4.2).
- For flush mounting or mounting in false ceilings, ensure that the tubes are not able to start oscillating by themselves.
- The exact definitive layout of the tubes – particularly in the case of flush mounting – must be documented precisely on the installation plans complete with dimensions.

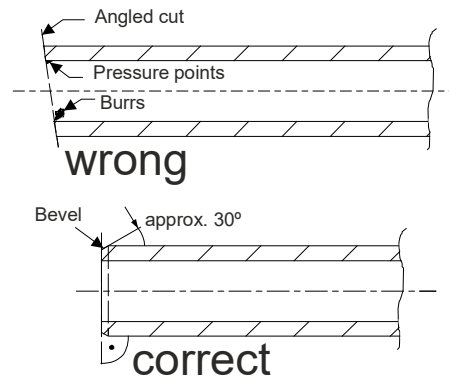

Fig. 19 Cutting the tubes

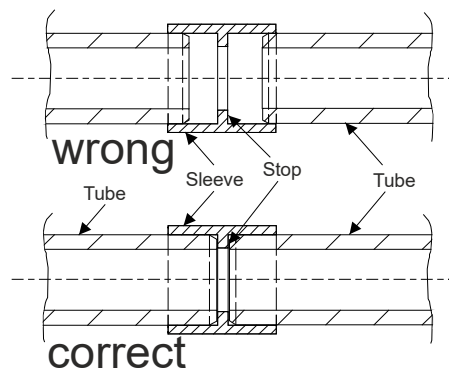

Fig. 20 Assembling the tubes

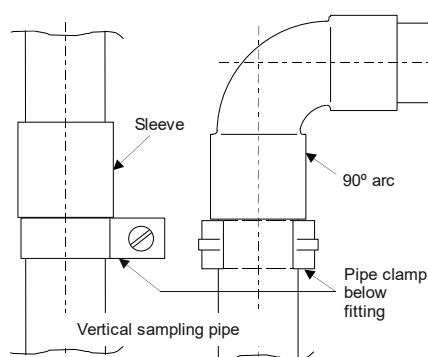

Fig. 21 Vertical sampling pipe

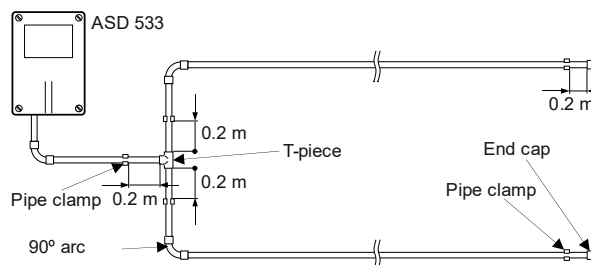

Fig. 22 90° bend, branching point

### 5.5.7 Mounting for equipment monitoring

When mounting for equipment monitoring (EDP installations, electrical cabinets etc.), plastic tube materials are to be used in principle. The same guidelines as described in Sec. 5.5.6 apply.

Equipment monitoring involves monitoring all the air outlet openings of the monitored devices. Please note that an ASD 533 can be fitted with a maximum of six sampling fixtures.

Whenever possible, the sampling pipe and detector housing are always secured directly to the object to be monitored.

#### 5.5.7.1 Screw-free fastening of the sampling pipe

Use the click-on pipe clamps to secure the sampling pipe parts (sampling fixtures) without screws. This allows the sampling fixture or sampling pipe to be removed quickly during maintenance work on the monitored objects.

The click-on pipe clamps are screwed onto the support rails by means of threaded plates.

The support rails are best fastened at right angles to the tube axis to ensure a precise positioning of the sampling pipe (sampling fixture).

Double-sided adhesive tape is used to secure the support rails in the desired position on the object, **Fig. 23**.

Before using the double-sided adhesive tape, make sure the adhesion surfaces are cleaned with a **non-aggressive** cleaning agent (e.g. soap suds or similar).

Cable ties can also be used for securing purposes instead of the double-sided adhesive tape.

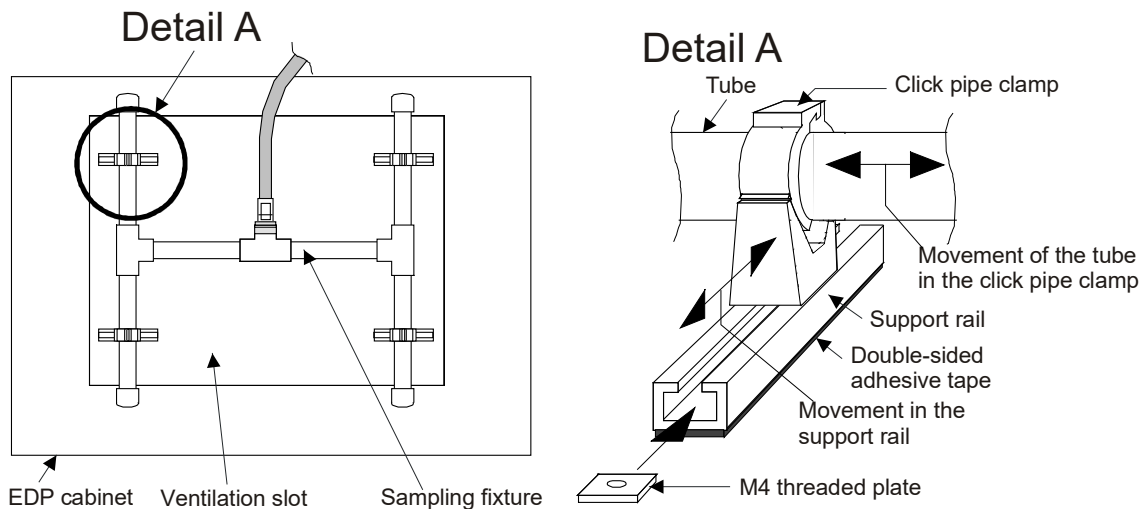

**Fig. 23 Screw-free fastening of a sampling fixture**

### 5.5.7.2 Transition to a flexible tube

With equipment monitoring, the transition from rigid to flexible tube can be made in principle using any type of fitting. The parts shown in **Fig. 24** are used for that purpose.

With a rigid sampling pipe made of **PVC** a **PVC adapter** with an M20 internal thread is glued to the fitting outlet. The M20 quick-release coupling is screwed into the adapter for the flexible tube.

If the rigid sampling pipe is made of **halogen-free ABS**, the procedure is identical to that for PVC. Here, however, a suitable **adapter made of ABS** is inserted instead of the PVC adapter.

The flexible tube is simply snapped into the quick-release coupling and snapped out of it again just as easily for maintenance work.

**Notices**

- Make sure the interfaces of the flexible tube are implemented “cleanly” so that the sealing ring in the quick-release coupling is not damaged.
- When clicking the flexible tube into place, make sure the tube and the quick-release coupling are pressed firmly against each other to prevent the intake of any leakage air.

For transitions from flexible tubes to sampling fixtures, proceed in the reverse order described above.

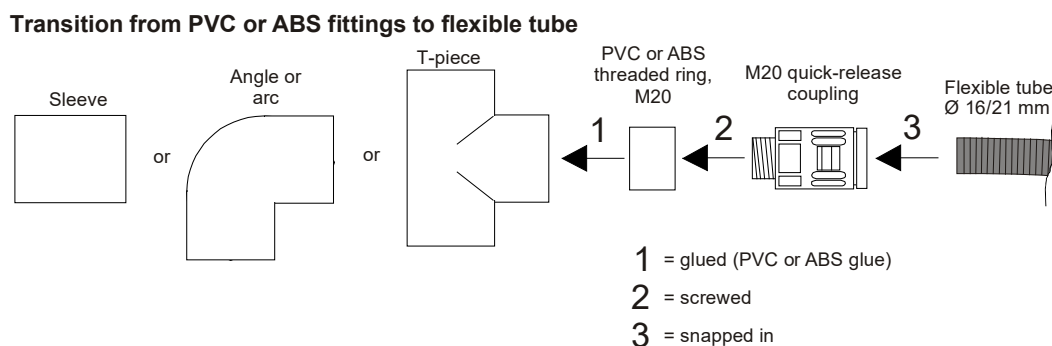

**Fig. 24 Transition from fittings to flexible tube**

## 5.5.8 Creating the sampling holes

The hole diameters of the sampling holes have to be determined and created by the customer as described in Sec. 4.4.4.5 and according to the specifications of the “ASD PipeFlow” calculation software or according to Sec. 4.5.4.1.

The sampling holes must be drilled cleanly so that no burrs or pressure points result. Use “new” drills with correctly ground surfaces (Fig. 25).

Whistling noises are a sign that the holes have not been neatly drilled. If so, the holes should be re-drilled and/or deburred.

For space surveillance, the sequence of hole diameters set out in Sec. 4.4.4.5 and the specifications of the “ASD PipeFlow” calculation software must be observed strictly.

If required, the sampling holes can be made using the special “sampling hole clips” (see Sec. 5.5.9).

For equipment monitoring, the sampling holes are drilled in the sampling fixture. The sampling holes are drilled into the sampling fixture in the direction of the air outlet from the object to be monitored. If required, these sampling holes can be fitted with sampling funnels (Sec. 5.5.10).

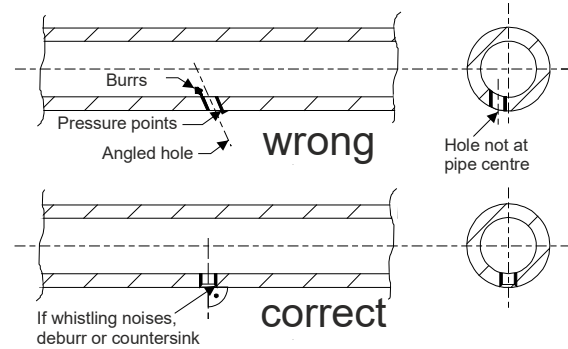

**Fig. 25 Creating the sampling holes**

## 5.5.9 Mounting the sampling hole clips and maintenance clips

**Possible only with plastic tubes (PVC/ABS)!**

At each required position in the sampling pipe drill a hole 8.5 mm in diameter (uniform Ø). The holes are made at right angles, in the centre of the pipe axis (as shown in Fig. 25).

The sampling hole clips are available in various sizes (Ø 2.0 / 2.5 / 3.0 / 3.5 / 4.0 / 4.5 / 5.0 / 5.5 / 6.0 / 6.5 / 7.0 mm). To determine the required sampling hole clips, refer to Sec. 4.4.4.5 and the specifications of the “ASD PipeFlow” calculation software or Sec. 4.5.4.1.

The sampling hole clips and the maintenance clips are clipped onto the sampling tube so they snap into the 8.5 mm borehole, Fig. 26.

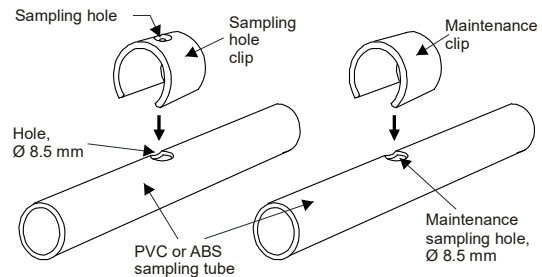

**Fig. 26 Mounting clips**

## 5.5.10 Mounting the sampling funnel

**Possible only with plastic tubes (PVC/ABS)!**

For equipment monitoring objects with a high air-flow rate (strong ventilation), the sampling holes can be fitted with funnels for optimal smoke detection.

If forced ventilation is used in rooms and/or on equipment, the use of sampling funnels is imperative.

The sampling funnels are secured to the tube of the sampling fixture and adjusted to the previously drilled sampling holes as described in Sec. 4.5.4.1, Fig. 27.

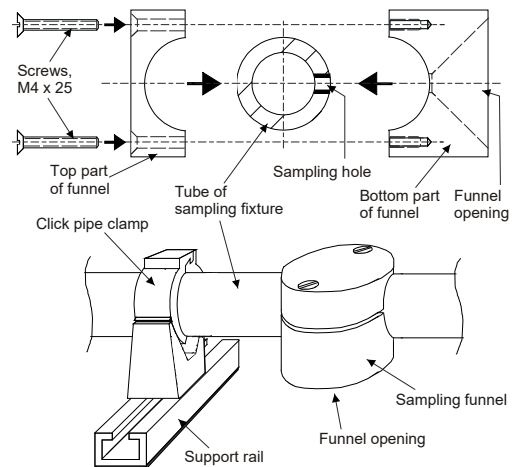

**Fig. 27 Using sampling funnels**

### 5.5.11 Mounting sampling stubs for a ceiling bushing

**Possible only with plastic tubes (PVC/ABS)!**

The parts required for a sampling stub for a ceiling bushing duct are shown in **Fig. 28**.

A T-piece is built into the sampling pipe at the required point.

The assembly sequence is carried out as indicated by the numbering **1 to 8**.

The sampling hole size (8) is selected based on the specification in Sec. 4.4.4.5 and/or the specifications of the "ASD PipeFlow" calculation software.

**Notices**

- Make sure the interfaces of the flexible tube are implemented "cleanly" so that the sealing ring in the quick-release coupling is not damaged.
- When clicking the flexible tube into place, make sure the tube and the quick-release coupling are pressed firmly against each other to prevent the intake of any leakage air.
- The maximum length of the flexible tube must not exceed **1.5 m**.

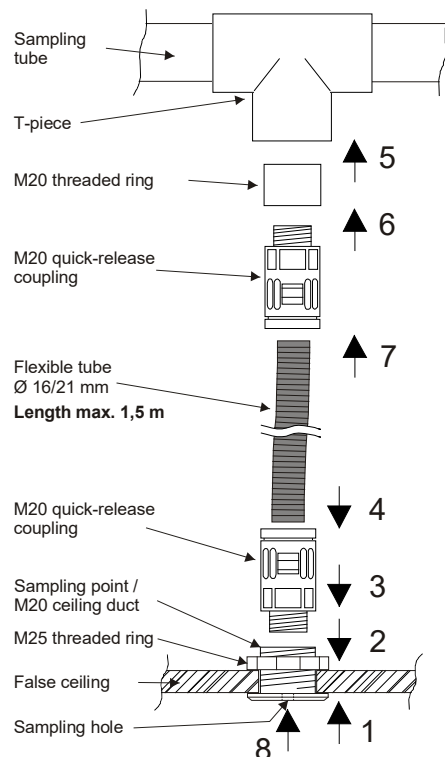

**Fig. 28 Mounting the ceiling bushing**

## 5.5.12 Mounting dust filter unit, dust trap box, dust retaining box, water retaining box

Applications with an extremely high level of dust and/or dirt, extreme temperature ranges and/or atmospheric humidity outside the specified limit values require the use of accessory parts as recommended by the manufacturer. For example:

- Dust filter unit;
- Dust trap box;
- Dust retaining box;
- Water retaining box;
- Manual ball valve for sporadic cleaning of the sampling pipe with compressed air;
- Automatic blow-out device



### Notices

The following rules must be adhered to when using accessory parts:

- The use of a dust filter unit by itself is possible.
- The water retaining box, dust retaining box and dust trap box should always be used in conjunction with a dust filter unit.
- An automatic blow-out device should be used in combination with a dust retaining box or a dust trap box and a dust filter unit.
- Dust filter unit, dust trap box, dust retaining box and water retaining box must always be mounted under the detector housing. The water retaining box and dust retaining box must be located at the lowest point (water drain). The specified minimum dimensions (0.5 m) must be adhered to.
- The mounting positions for the water retaining box, dust trap box and dust retaining box must be observed as indicated in Fig. 29.

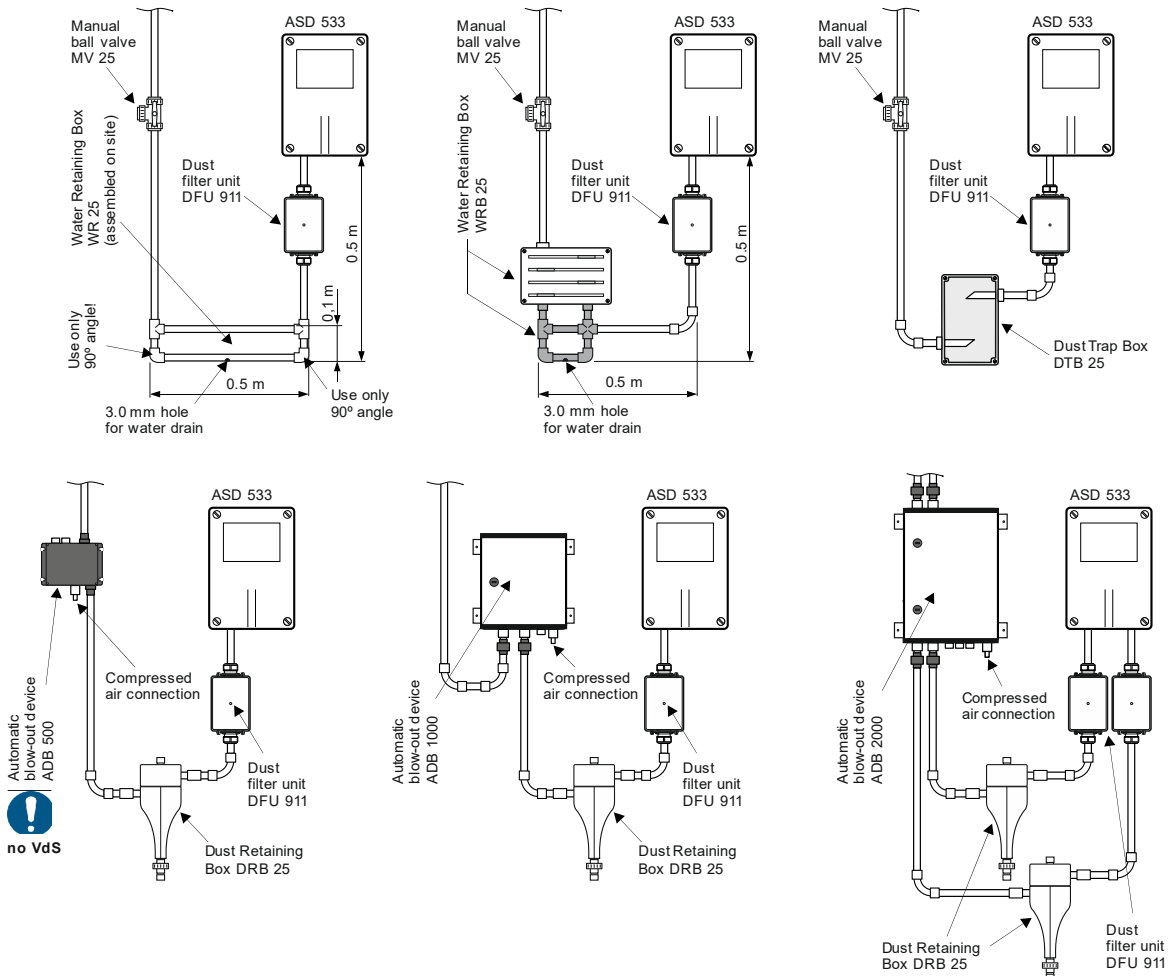

Fig. 29 Mounting accessory parts

## 6 Installation

### 6.1 Regulations



#### Notices

- The electrical installation is to be carried out in accordance with the applicable country-specific regulations, standards and guidelines. Likewise, the local provisions must also be observed.
- Besides country-specific regulations and guidelines, the specifications concerning requirements for installation cables and conductor cross-sections as described in Sec. 4.9 must be observed and implemented.

### 6.2 Cable entry

To facilitate the installation work, remove the entire housing cover of the detector housing (including control unit) from the device. To do so, unplug the 10-pin ribbon cable connector from the AMB 33 Main Board.



#### Notice

Make sure the power is disconnected for all connection and wiring work on the ASD 533.

There are three M20 cable screw unions in the detector housing for feeding in the electrical installation. If needed, an additional two cable screw unions (1 x M20, 1 x M25) can be fitted in two reserve holes (blind plugs).

The cable screw unions are suitable for cables with external diameters ranging between 5 to 12 mm (M20) or 9 to 18 mm (M25).



#### Notice

- The device ships with the cable screw unions sealed with a dust-protection insert; remove the inserts before feeding in the cables. The dust-protection inserts merely prevent the ingress of any dust and/or dirt during the mounting of the device and do not provide any mechanical protection. Any cable screw unions that are not in use must be replaced with blind plugs (mounting set) to maintain the IP 54 protection class.
- **Use in compliance with UL 268:** When using the ASD 533 in compliance with UL 268, special 1/2" and 3/4" cable screw unions are to be used (customer-side). To be able to use them in the ASD housing, the existing M20 and M25 screw-junction pieces must be removed and replaced by 1/2" M20 adapters and 3/4" M25 adapters. The adapters are available from the manufacturer in the **AD US M-Inch** range of accessories.

## 6.3 Using the smoke sensors

When the ASD 533 is delivered, the smoke sensors are already fitted. These must be removed from the detector housing for the installation of the ASD (release two lock clamps per smoke sensor), but they must remain in their protective packaging until final commissioning. The final installation is to be carried out as described below.



### Notices when deploying the smoke sensors

- Always leave the smoke sensors inside their protective packaging until it is ready to be installed definitively in the detector housing.
- Depending on the circumstances (e.g. long period of time between mounting and commissioning or if the environment is extremely dusty (construction work)), only remove the smoke sensors from their protective packaging and insert it definitively in the detector housing when commissioning the ASD 533.
- Before installing the smoke sensors check that the insect protection screens are properly fitted to the smoke sensor chamber at the air inlet and outlet.
- The smoke sensor chamber must be absolutely free of any dirt and/or dust. Remove any residue resulting from mounting the detector housing.

The installation position of the smoke sensors depends on the particular smoke sensor chamber (I or II). The installation position is always such that the connectors of the smoke sensors are oriented toward the outside of the ASD housing. Incorrect installation positioning is prevented by the anti-twist rib on the smoke sensor housing.

The smoke sensors are fastened with the two lock clamps in the ASD housing. The flat cable delivered with the smoke sensor is connected to the smoke sensor (big flat cable connector) and to the AMB 33 Main Board (small flat cable connector).

The insect protection screens and lock clamps are not fitted to smoke sensor chamber II on the ASD 533-1 (only one smoke sensor). Instead of using the insect protection screens, the air channels are closed. Smoke sensor chamber II remains open for operation.

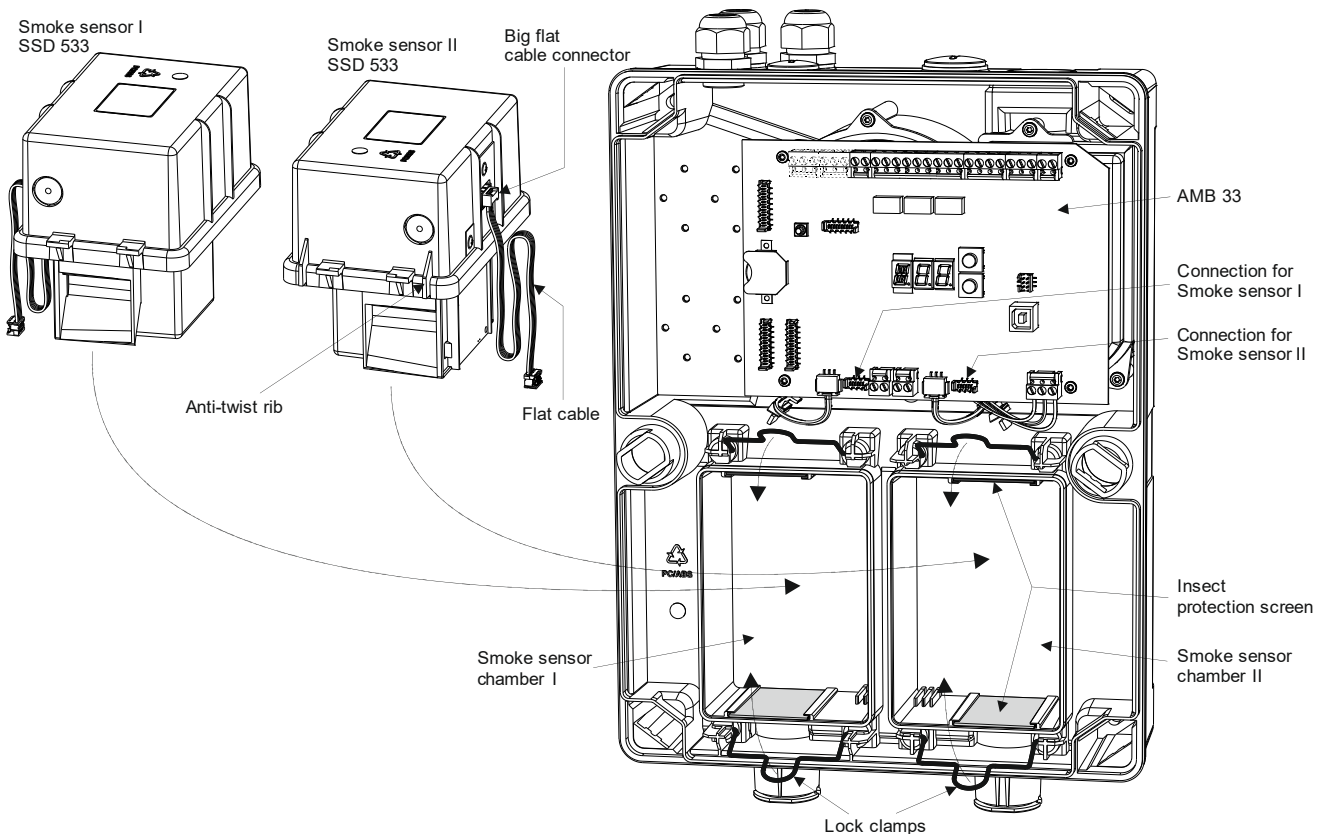
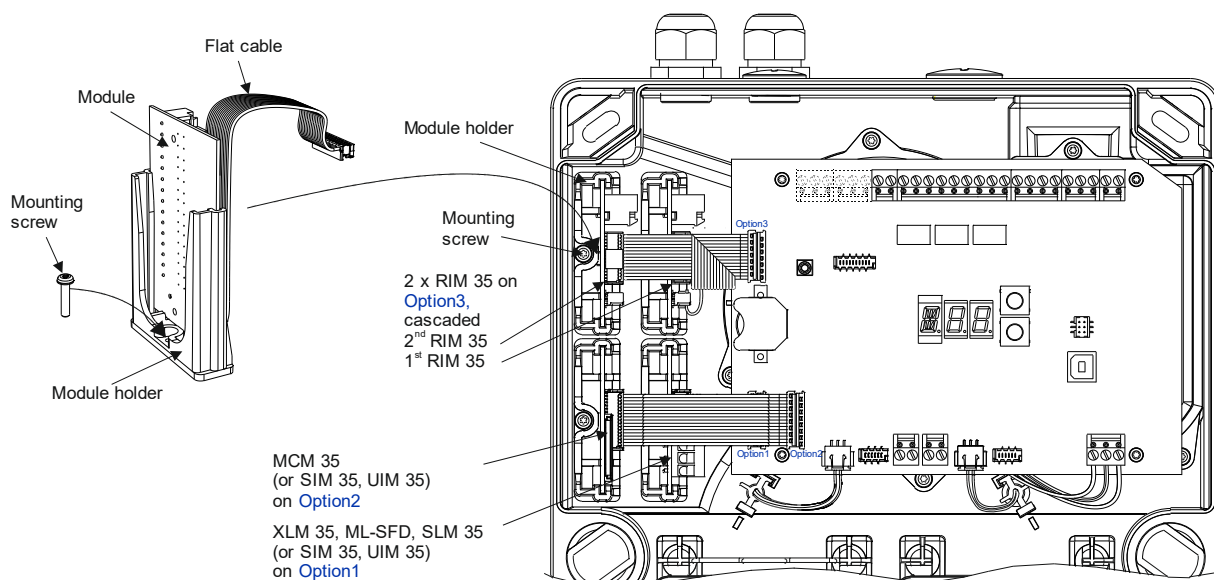

Fig. 30 Using the smoke sensors

## 6.4 Installing additional modules

There are four expansion slots for fitting the detector housing with optional additional modules. Given the modular assignment of ribbon cable connectors on the AMB 33 Main Board (see also Sec. 3.2, **Fig. 5**), it is recommended to observe the arrangement shown in **Fig. 31**.

The mounting set of each module comprises a module holder, mounting screw and the connecting cable (ribbon cable) for connecting to the AMB 33. Use a **Torx screwdriver T15** to tighten the mounting screw. The module can be removed from the module holder for mounting in the detector housing and for the subsequent electrical installation.



**Fig. 31** Installing additional modules



### Notice

The additional modules are automatically detected when the device is switched on, from which point they are monitored and functional. The MCM 35 begins logging data as soon as the SD memory card is inserted (approx. after 10 s; indicated by the flashing red LED on the MCM). To read out the SD memory card or when subsequently removing an additional module (e.g. because it is not being used), the additional modules must first be logged off via operation on the AMB 33 Main Board (o switch position, see Sec. 7.3.7).

For installing modules other than XLM, ML-SFD, SLM, RIM, MCM, SIM or UIM universal module support. This module support is secured to the detector housing instead of the module holders described above and requires two expansion slots one above the other (directly next to the AMB 33). The UMS 35 consists of an angled sheet metal plate with various fastening options for additional modules.



### Notice, XLM 35, ML-SFD installation

With the installation of the use of an XLM 35 or ML-SFD, the ASD 533 meets the requirements in compliance with **EN 54-17** (short-circuit isolation). To ensure that the required identification is recognisable in compliance with EN 54-17, the supplied **identification sign must** be easily visible **outside** on the ASD housing and attached in the immediate vicinity of the ASD rating plate (same side) when the XLM 35 or ML-SFD is installed.

## Installation

### 6.5 Electrical connection

The electrical connection is implemented by means of plug-in screw terminals. Use a **flat-blade screwdriver No. 1** (3.5 mm) to tighten the screw terminals.



#### Notice

Inside the detector housing the lines should be fed to the terminals using the shortest possible route. Reserve loops via the Main Board are to be avoided (EMC).

#### 6.5.1 Terminal assignment for the AMB 33 main board

AMB terminal	Signal	Wiring
1	+10.5 to +30 VDC (UL/FM = 12.4 to 27)	Main power supply line from FACP or external according to <b>Fig. 32</b>
2	0 V	
3	+10.5 to +30 VDC (UL/FM = 12.4 to 27)	Redundant power supply line from FACP or external according to <b>Fig. 32</b>
4	0 V	
5	+ power supply	Interconnection of feedback loop signals according to <b>Fig. 39</b>
6	Fault output, <b>OC</b> (all fault events)	
7	Alarm output, <b>OC</b>	
8	Freely programmable, <b>OC</b>	
9	unused	
10	Rel. 1 ("NO") ①	Fault
11	Rel. 1 ("NC")	
12	Rel. 1 "COM" ①	
13	Rel. 2 "NO"	Alarm I
14	Rel. 2 "NC"	
15	Rel. 2 "COM"	
16	Rel. 3 "NO"	Alarm II or freely programmable
17	Rel. 3 "NC"	
18	Rel. 3 "COM"	
19	External reset input + (opto-isolator input)	Interconnection according to <b>Fig. 33</b> and <b>Fig. 35</b>
20	External reset input – (opto-isolator input)	
21 - 26	unused (not fitted on ASD 533-2)	



#### Notice

① The "Fault" relay has picked up in the release state → contact Te. 12/10 closed, 12/11 open (ASD 533 under voltage; no fault event present).

#### AMB 33 internal connections

AMB terminal	Signal	Wiring
MOT / M-	Fan -	Fan, black wire
MOT / T	Fan tachometer signal	Fan, white wire
MOT / M+	Fan +	Fan, red wire
OEM1 / AI-	Opto-isolator inputs for OEM1 "OEM1 / St" can also be used for activating the day/night control (priority over fault triggering).	Interconnection similar to <b>Fig. 33</b> (see also Sec. 2.2.8)
OEM1 / AI+		
OEM1 / St-		
OEM1 / St+		



#### Notices

- In some cases actuations via the OEM inputs may **not** comply with requirements **in accordance with EN 54-20** and may therefore only be used after consulting with the manufacturer.
- The OEM inputs are **not** line-monitored.

### 6.5.2 Terminal assignment line module XLM 35 / ML-SFD / SLM 35

XLM	Terminal		Signal	Wiring
	ML-SFD	SLM		
L1	P1	T	Data A	Addressable loop according to <b>Fig. 35</b> or <b>Fig. 38</b> (see also Sec. 8.5.4)
C1	N1	U	GND A	
G1	S1	V	Screen	
L2	P2	X	Data B	Addressable loop according to <b>Fig. 35</b> or <b>Fig. 38</b> (see also Sec. 8.5.4)
C2	N2	Y	GND B	
G2	S2	Z	Screen	

### 6.5.3 Terminal assignment for RIM 35 relay interface module

RIM terminal		Signal ①	Wiring
1	Rel. 1	"NO"	Pre-signal 1 or freely programmable
2		"NC"	
3		"COM"	
4	Rel. 2	"NO"	Pre-signal 2 or freely programmable
5		"NC"	
6		"COM"	
7	Rel. 3	"NO"	Pre-signal 3 or freely programmable
8		"NC"	
9		"COM"	
10	Rel. 4	"NO"	Smoke sensor soiling or freely programmable
11		"NC"	
12		"COM"	
13	Rel. 5	"NO"	Sampling pipe blockage or freely programmable
14		"NC"	
15		"COM"	



#### Notice

- ① The criteria (signals) assigned ex works can be modified using the "ASD Config" configuration software. If two RIM 35 devices are used on the ASD 533, the relays of the second RIM 35 are not configured with any default criteria. The required programming must be carried out using the "ASD Config" configuration software.

### 6.5.4 Terminal assignment of an SIM 35 serial interface module

SIM terminal	Signal	Wiring / installation (see also Sec. 8.5.6)	
1	GND	Input	1 <sup>st</sup> conductor from wire pair 2
2	D +		1 <sup>st</sup> conductor from wire pair 1
3	D –		2 <sup>nd</sup> conductor from wire pair 1
4	GND	Output	1 <sup>st</sup> conductor from wire pair 2
5	D +		1 <sup>st</sup> conductor from wire pair 1
6	D –		2 <sup>nd</sup> conductor from wire pair 1

## 6.6 Connection variants



### Notice

The connection variants are determined by the possible line and FACP technologies used. For more information on interconnecting alarm transmitters, line monitoring elements, etc., please contact the manufacturer and/or supplier of the fire alarm system.

In all cases the ASD 533 must have an emergency power supply (country-specific, e.g. compliant with EN 54-4).

### 6.6.1 Power supply

The ASD 533 must always have an emergency power supply. Depending on the output current available at the fire alarm control panel (FACP) and the number of ASD 533 units to be connected, the power supply can be provided by the FACP; alternatively, an additional power supply must be provided locally.

The supply is via terminals 1 and 2. In applications which stipulate a redundant power supply line (country-specific), it is routed to terminals 3 and 4 (Fig. 32).

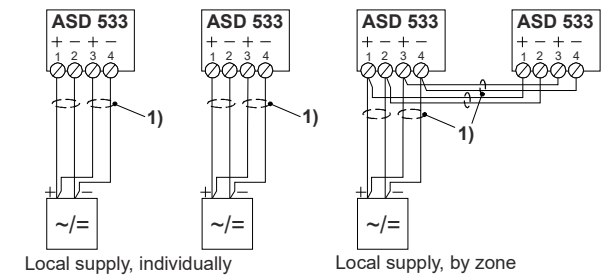
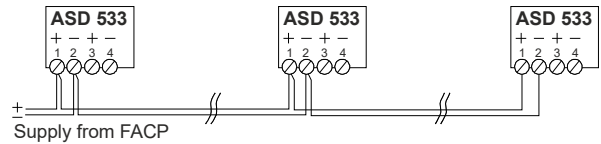

Local supply, individually  
Local supply, by zone  
1) Redundant power supply line (optional, country specific)

Fig. 32 Types of power supply



### Notices

- The supply inputs are not connected internally in the ASD and therefore cannot be used for direct forwarding to neighbouring systems.
- The terminals of the ASD 533 are designed for a maximum of 2.5 mm<sup>2</sup>. For forward the power supply line to a neighbouring ASD it may therefore be necessary to install additional distributor or support terminals.
- **Application in the Chinese market:** for each ASD 533, a fuse holder with a 1.6 A fine fuse is installed in front of supply terminal 1 (+) of the AMB 33 (included in the mounting set).



### Notice

To determine the required power supply and cable cross-section, the calculations set out in Sec. 4.9.2 must be carried out in all cases. In applications with a redundant power supply, the calculations must be carried out for both power supply lines individually.

### 6.6.2 Reset input

The reset input is potential-free (opto-isolator) and can be actuated on both the “plus” side and the “minus” side, Fig. 33. The input operates in the 5 to 30 VDC range and a pulse bandwidth of 0.5 to 10 s. Thanks to the continuous current consumption of approx. 3 mA across the entire operating range, actuation can be carried out directly via an open collector output.

If a continuous signal is imposed for longer than 20 s, the ASD 533 is switched inactive, the fault relay becomes active (triggers), and the fan is switched off. Once the continuous signal is switched off, the ASD is re-armed. Switching inactive via the “Reset external” input works only if no XLM 35, ML-SFD or SLM 35 is fitted to the ASD 533.

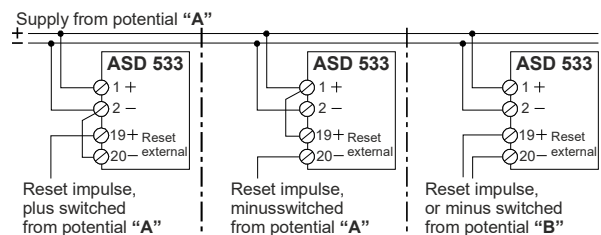

Fig. 33 Reset input

### 6.6.3 Control

The ASD 533 units connected to a FACP are controlled according to the detection zone mapping using the FACP states “Zone On/Off” and “Reset”. Two possibilities are available:

- Control via supply voltage (auxiliary relays in the ASD power supply line);
- Control via the “External reset” input.

#### 6.6.3.1 Control via supply voltage by means of auxiliary relay

Depending on the location of the ASD power supply, the auxiliary relay may be placed in the FACP or directly in the ASD 533.

The auxiliary relay can be actuated in the following ways (see Fig. 34):

- line plus or minus;
- SW output of the FACP;
- SW output or function of a control module.

The function types described above are determined by the FACP technology used; it is therefore essential to contact the manufacturer and/or the supplier of the FACP for details before implementing.

### Notices

- The EMC protective elements at the input of the ASD electronics cause a brief current peak (5 A / 1 ms) when the supply voltage is applied. When using auxiliary relays with a maximum contact rating of 1 A, this may lead to the relay contact sticking. For this reason auxiliary relays with a contact rating of **more than 1 A** should be used **as a matter of principle** – e.g. semi-conductor relay PMR 81 (see Fig. 34 C).
- The ASD supply path routed via the auxiliary relay contact must be short-circuit-proof or routed via a fuse component (circuit-breaker card).
- When using a PMR 81 semi-conductor relay, it may be necessary to invert the actuation signal (PMR only has a normally open (NO) contact function).
- To guarantee full emergency operation, the interconnection must always be implemented in such a way that ASD operation is guaranteed even in the event of an FACP computer failure (reset input not actuated).

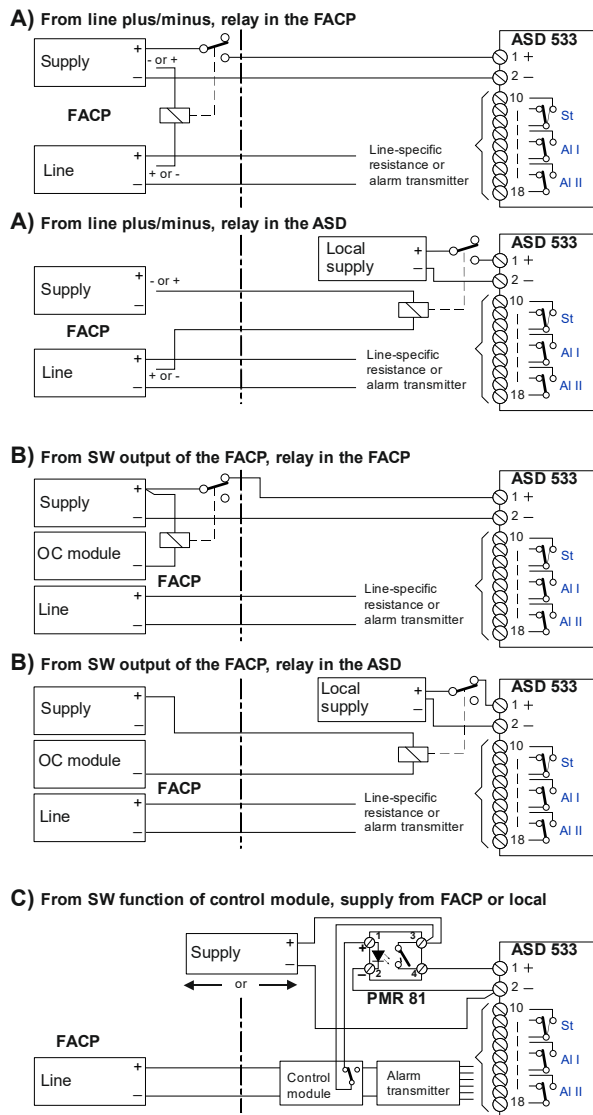

Fig. 34 Control via supply with relay

## 6.6.3.2 Control via the “Reset external” input

The following options are available for control via the reset input (see Fig. 35):

- A. Control via auxiliary relay from line plus;
- B. Control via auxiliary relay or semi-conductor relay (PMR 81) from control output (open collector);
- C. Control without auxiliary relay, directly from control output (relay contact or open collector);
- D. Control via addressable loop when using the XLM 35 / ML-SFD / SLM 35. Control is then not via the reset input but directly with the corresponding command input via the XLM 35 / ML-SFD / SLM 35 on the ASD 533.

The function types described above are determined by the FACP technology used; it is therefore essential to contact the manufacturer and/or the supplier of the FACP for details before implementing.



### Notices

- When using a PMR 81 semi-conductor relay, it may be necessary to invert the actuation signal (PMR only has a normally open (NO) contact function).
- To guarantee full emergency operation, the interconnection **must always** be implemented in such a way that ASD operation is guaranteed even in the event of an FACP computer failure (reset input not actuated).
- **Attention:** When control is via the “Reset external” input, the ASD 533 is supplied with voltage even if the zone (FACP) is switched off. For this reason, the power supply line to the ASD must be disconnected to carry out any repair work (e.g. unplug terminals 1 and 2 on the ASD; also 3 and 4 in the case of a redundant supply).

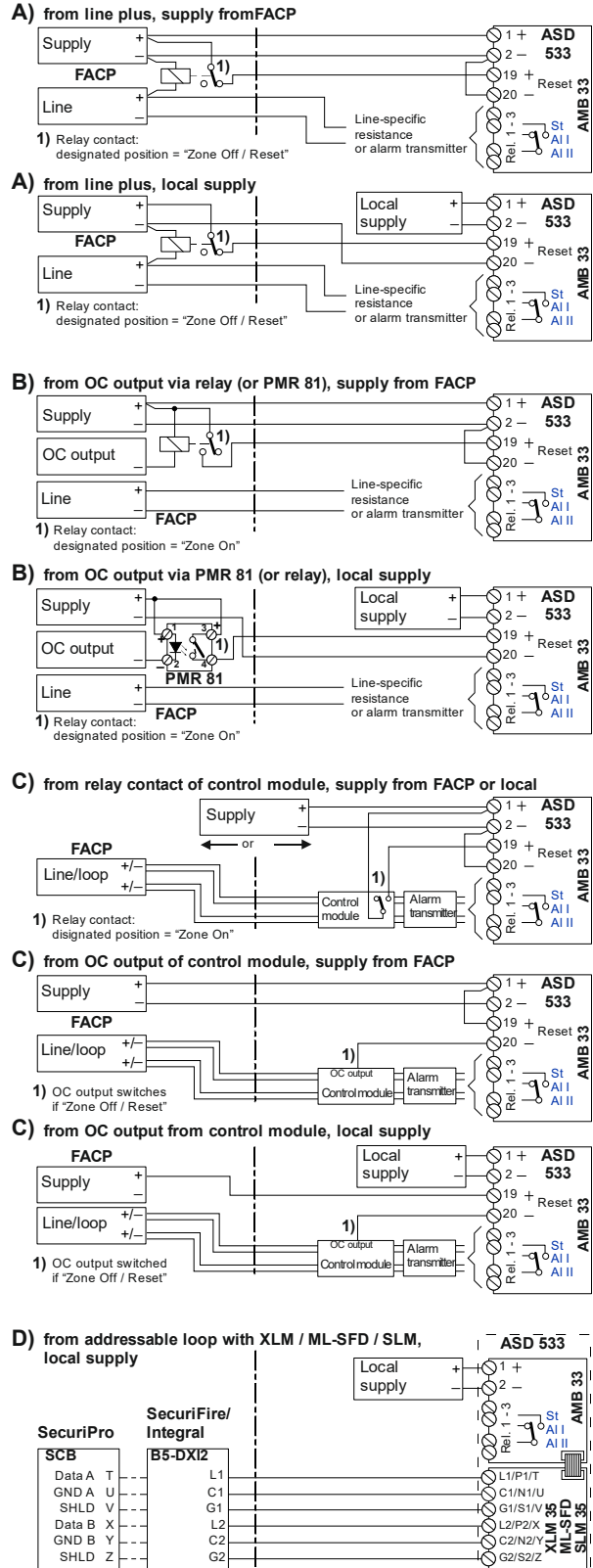

## 6.6.4 Interconnecting the FACP line

Each of the following examples illustrates the control via reset input according to Sec. 6.6.3.2. If interconnection with the control via the voltage supply is required, the control circuit in the figures below can be implemented as described in Sec. 6.6.3.1.

### 6.6.4.1 Interconnection on zone detection via AI / St relay

- For circuitry on zone detection lines, actuation of the auxiliary relay is, as a rule, from the line plus. A condition for this, however, is that the line plus also switches for "Zone On/Off" and "Reset" (see Fig. 36, C) for exception).
- Circuitry as shown in Fig. 36, B) is used exclusively when the FACP line is to operate with **2-detector dependency (V-AI / H-AI)** from smoke sensors I and II. For that purpose the FACP line is programmed for 2-detector dependency. The ASD has **two** sampling pipes which cover the **same monitoring area**, or only **one**, and **merging** takes place before the ASD on tube input I and II (see Sec. 4.6).
- When wiring as shown in Fig. 36, C), AI I and AI II can be evaluated in the FACP as independent zones from two independent monitoring areas. A **2-line dependency** can also be programmed in the FACP. In that case, the same applies as in B); both sampling pipes from one monitoring area or merging of a sampling pipe on tube input I and II according to Sec. 4.6.
- If wiring as in Fig. 36, C) is used, the control signal for the reset input can no longer be picked up from the line plus; instead, a software output has to be created with the following programming:

Output switches when:

**Line/Zone A or B "Reset"**

or:

**Line/Zone A and B "Off"**

A) ASD 533 with one smoke sensor, connected on one line

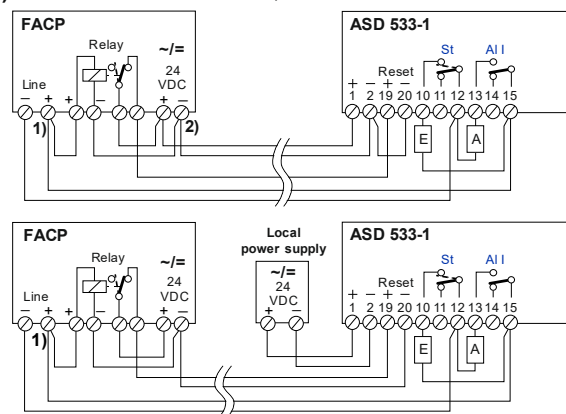

B) ASD 533 with two smoke sensors, connected on one line

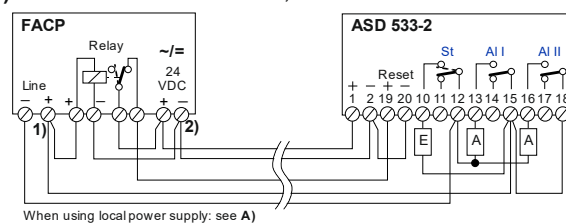

C) ASD 533 with two smoke sensors, connected on two lines

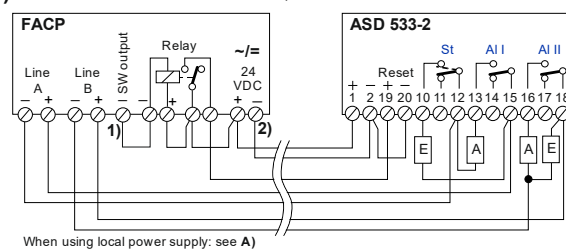

- Output switches when: "Line/zone A or B reset" or: "Line/zone A and B Off"
- from circuit-breaker card if not short-circuit proof

E = terminal resistor (only in the last ASD)  
A = alarm resistance

Fig. 36 Connection to zone detection

## Installation

### 6.6.4.2 Interconnection on selective identification or addressable loop via AI / St relay

- For line technologies such as selective identification lines and addressable loops, actuation of the auxiliary relay is to be implemented from a software-controlled output (output card or control module). The output is programmed via the FACP software with the “Zone Off” and “Reset” functions.
- If **AI I** and **AI II** are evaluated in the FACP as individual zones (also 2-line dependency), programming of the SW output is as follows:

Output switches when:

**Zone A or B “Reset”**

or:

**Zone A and B “Off”**

A normal relay or a PMR 81 semi-conductor relay can be used as control relay.

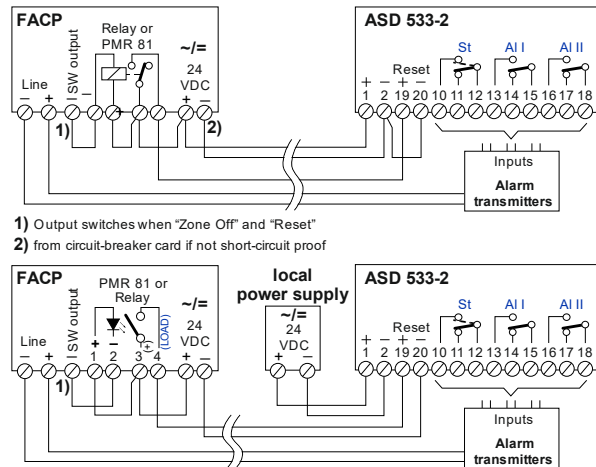

Fig. 37 Connection on selective identification or addressable loop

### 6.6.4.3 Interconnection on SecuriPro / SecuriFire / Integral addressable loop from XLM 35 / ML-SFD / SLM 35

- No additional control relay is required for interconnection on the SecuriPro / SecuriFire / Integral addressable loop from the XLM 35 or SLM 35. Likewise the **AI** and **St** relays of the ASD 533 are not required. The status query and control of the ASD 533 are carried out directly between the XLM 35, ML-SFD or SLM 35 and the addressable loop.
- When using an ASD 533-2 with two smoke sensors and XLM 35, ML-SFD or SLM 35, a 2-detector dependency (**V-AI** / **H-AI**) can be programmed on the FACP. Evaluation of the individual zones (**AI I** and **AI II**) in the FACP is also possible.
- On the **SLM 35** the S2 switch is positioned at “I” or “I + II”, depending on the ASD type (number of smoke sensors).

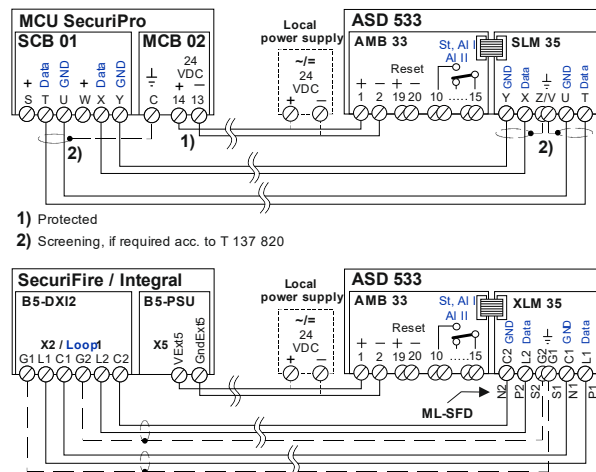

Fig. 38 Interconnection from XLM 35 / ML-SFD / SLM 35

#### Maximum number of connectable XLM 35 / ML-SFD / SLM 35:

(see also notice below)

- |  |            |
|--|------------|
| for each SecuriLine (SLM 35 only)                        | 50 units   |
| for each SecuriFire / Integral addressable loop (XLM 35) | 32 units ① |
| for each SecuriFire / Integral addressable loop (ML-SFD) | 28 units ① |

① country-specific regulations and guidelines must be observed.



#### Notices

- The **SLM 35** has two switches S1 and S2, which have to be set differently according to the application of the ASD 533. See also under Sec. 8.5.4.
- The interconnection and line routing between **SLM 35** and the SecuriPro, SecuriFire and Integral FACP is to be carried out in accordance with **Fig. 38** (X to X, Y to Y and X to L2, Y to C2, etc.).
- The installation of the SecuriFire / Integral addressable loop must be shielded.
- The interconnection and line routing between **XLM 35 / ML-SFD** and the SecuriFire and Integral FACP is to be carried out in accordance with **Fig. 38** (L1 to L1, C1 to C1, etc.).
- The **identification sign** (EN 54-17) supplied with the XLM 35 or ML-SFD **must** be attached outside on the ASD (next to the ASD rating plate).

### 6.6.5 Open collector outputs

The ASD criteria “Alarm I”, “Alarm II” and “Fault” (all fault events) are available as open collector outputs.

Parallel and feedback indicators or other consumers (e.g. relays) can be connected to the open collector outputs.

In ASD 533-1 the output on terminal 8 is not “Alarm II” but rather freely programmable (it is always identical with the programming on relay 3 of the AMB 33).

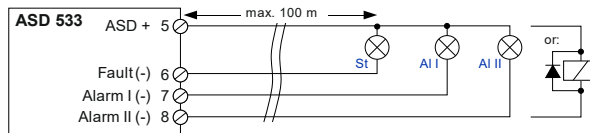

Fig. 39 Interconnecting the OC outputs



#### Notices

- When connecting inductive consumers (e.g. relays), a free-wheeling diode is to be installed directly at the consumer, **Fig. 39**.
- The outputs are 0 V-switched and have a maximum loading capacity of **100 mA** per output. All the outputs together cannot switch more than **200 mA**. The dielectric strength per output is 30 VDC. The outputs are short-circuit-proof but not potential-free. Connection to the outputs affects the overall power consumption of the ASD 533.

## 7 Commissioning

### 7.1 General



#### Notices

The following points must be observed when commissioning the ASD 533 aspirating smoke detector:

- The ASD 533 is to be commissioned by trained and qualified personnel only.
- Prior to commissioning it is important to ensure that the entire sampling pipe has been laid correctly (junctions, sampling holes).
- If a maintenance sampling hole is provided as described in Sec. 4.4.4.6, it must be closed with adhesive tape or the maintenance clip.
- Prior to commissioning, the mounting and installation are to be inspected to ensure that switching on the power supply will not damage the ASD 533 in any way.
- Any rewiring of the device is to be carried out only once the power supply is disconnected. Exception: logging off additional modules XLM, ML-SFD, SLM, RIM, MCM, SIM, UIM (see Sec. 7.3.7).
- The smoke sensors are to be removed from their protective packaging and definitively fitted and connected inside the detector housing (see Sec. 6.3).
- Before switching on, any additional modules are to be fitted in the detector box and connected to the AMB 33 main board using the enclosed ribbon cable. See also Sec. 6.4.
- Before switching on the ASD power supply, ensure that all fire incident controls and remote alerting from the ASD 533 are blocked or deactivated.
- Immediately before switching on the ASD 533 for the first time, remove the isolating strip from the lithium battery (AMB 33).

The detector housing has to be opened for commissioning the ASD 533 (see Sec. 5.4.1). To prevent the housing cover from dangling loosely from the ribbon cable connection to the AMB 33, secure it to the middle mounting points using the top rotary snap locks (**Fig. 40**).

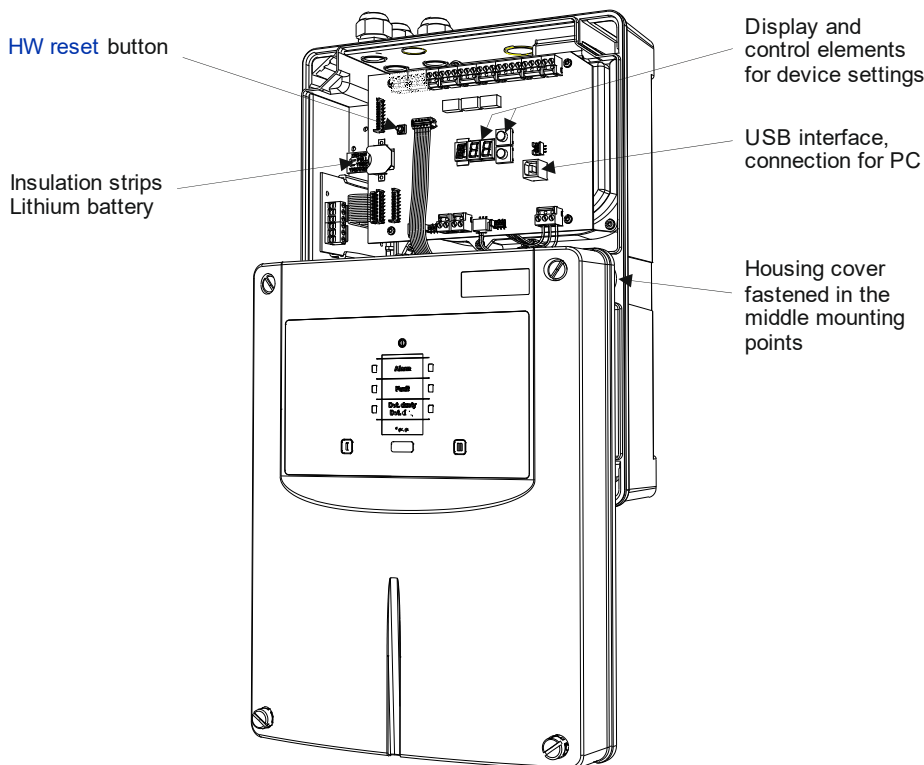

**Fig. 40** Detector housing opened for commissioning

## 7.2 Programming

The ASD 533 has several switch positions, which are configured with permanently assigned parameters:

- Normative system limits according to EN 54-20, Class A to C, switch positions **A11** to **C32**;
- Non-normative system limits, switch positions **W01** to **W48**;
- Configurable switch positions for saving the settings after using “ASD PipeFlow” and/or changing the device configuration using the configuration software “ASD Config” or SecuriPro, SecuriFire or Integral FACP (XLM 35, ML-SFD or SLM 35), **X01** to **X03**.

A detailed description of all the switch positions can be found in Sec. 8.3.

If the ASD 533 is operated with **EasyConfig**, i.e. within the present system limits according to the tables in Sec. 4.4.4.3 and 4.4.4.4, only select the corresponding switch positions **A11** to **C32** and **W01** to **W48** – it is not necessary to use the “ASD Config” configuration software to do so.

In systems where the “ASD PipeFlow” calculation software was used for planning the sampling pipe, the smoke sensor response sensitivity calculated by “ASD PipeFlow” is to be programmed on the ASD 533 using “ASD Config”. The data is then saved on the ASD 533 under one of the freely configurable switch positions **X01** to **X03**. The ASD 533 is then operated on the corresponding switch positions **X01** to **X03**.

The device ships with default values already stored under switch positions **X01** to **X03**. Specifically:

- position **X01** with position **A11** (for ASD 533-2 = **A12**);
- position **X02** with position **b11** (for ASD 533-2 = **b12**);
- position **X03** with position **C11** (for ASD 533-2 = **C12**).

The following parameters can be modified using the “ASD Config” configuration software (see Sec. 7.2.1):

- Smoke sensors alarm threshold;
- Trigger thresholds for dust and soiling (individually);
- Trigger thresholds for pre-signals 1, 2 and 3 (individually, for each smoke sensor);
- Delay times for dust/soiling, pre-signal, alarm and fault (individually);
- Sensitivity and delay time of the airflow monitoring;
- Deactivate of latching for dust/soiling, pre-signal, alarm and fault (individually);
- Deactivate criteria (pre-signals, dust/soiling, faults);
- Date/time;
- Autolearning (On/Off, duration);
- Day/night operation;
- Relay allocation (AMB 33 relay 3, RIM 35);
- Open collector output 3 (always like AMB 33 relay 3).

### Notice

The parameters are configured and stored ex works with default states and values to meet the triggering properties required by EN 54-20. Changing the parameters may result in non-compliance with EN 54-20. Adjustments or modifications to the ASD 533 using “ASD Config” may only be carried out by the manufacturer or by persons under the supervision of and trained by the manufacturer.

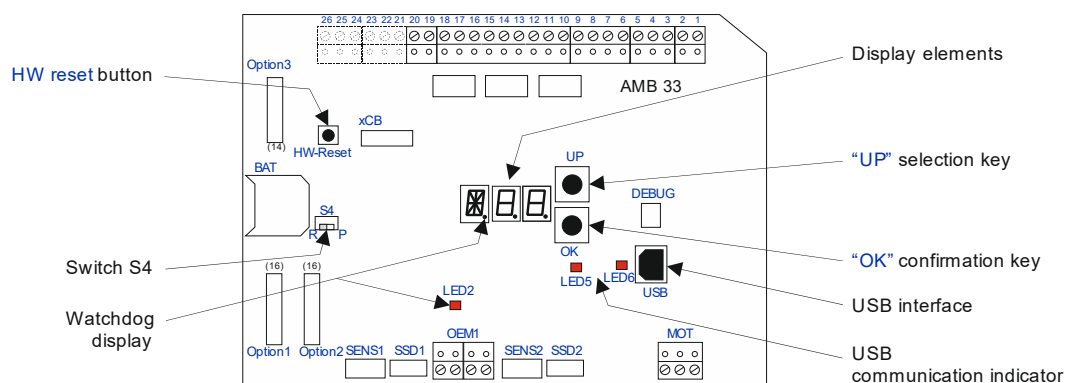

**Fig. 41 Control and display elements on the AMB 33**

## 7.2.1 Configuration options

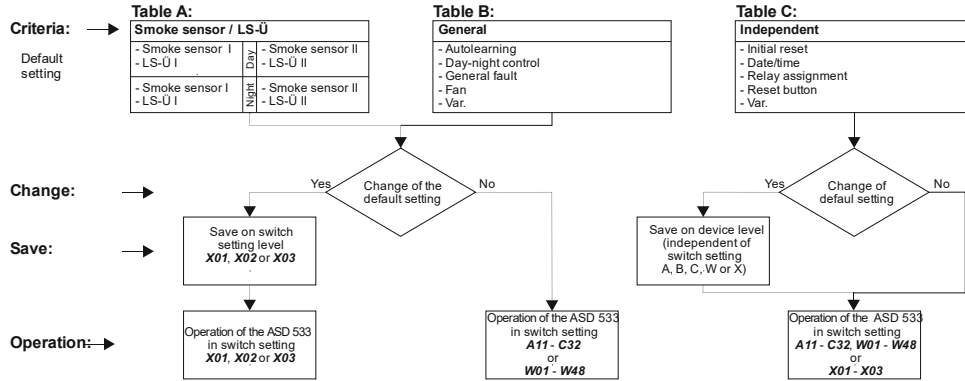

Fig. 42 Configuration overview

**Table A:** The following criteria can be set for each smoke sensor/sampling pipe. Also, the criteria for day/night control can be separately set. Configuration changes are saved on one of the freely configurable switch positions **X01** to **X03**.

Sector • Parameter	Default setting	Area	Resolution / levels	Saving after change
<b>Alarm 2</b>				
• Alarm 2 On / Off	Off	Off / On		<b>X01 – X03</b>
• Sensitivity (always at least 20% above alarm)	1%/m	– 10 %/m	0.0002 %/m	<b>X01 – X03</b>
• Alarm 2 delay	2 s	0 s – 60 s	1 s	<b>X01 – X03</b>
• Alarm 2 latching	On	On / Off		<b>X01 – X03</b>
• Hold time for area switchover (AI 2 to AI)	20	10 – 250	1 s	<b>X01 – X03</b>
<b>Alarm (EN 54-20)</b>				
• Alarm threshold	<b>C11 / C12</b>	0.02 – 10%/m	0.0002 %/m	<b>X01 – X03</b>
• Smoke level value averaging (number)	4	1 – 10	1	<b>X01 – X03</b>
• Alarm delay (UL/ULC max. 30 s)	2 s	0 s – 60 s	1 s	<b>X01 – X03</b>
• Alarm cascading	Off	Off / On		<b>X01 – X03</b>
• Alarm latching	On	On / Off		<b>X01 – X03</b>
<b>Pre-signal</b>				
• Pre-signal 1 On / Off	On	On / Off		<b>X01 – X03</b>
• Pre-signal 2 On / Off	On	On / Off		<b>X01 – X03</b>
• Pre-signal 3 On / Off	On	On / Off		<b>X01 – X03</b>
• Pre-signal 1 (100% = alarm threshold)	30 %	10 – 90 %	10 %	<b>X01 – X03</b>
• Pre-signal 2 (100% = alarm threshold)	50 %	VS 1 + 10 – 90%	10 %	<b>X01 – X03</b>
• Pre-signal 3 (100% = alarm threshold)	70 %	VS 2 + 10 – 90%	10 %	<b>X01 – X03</b>
• Pre-signal delay (VS 1 – VS 3)	2 s	0 s – 60 s	1 s	<b>X01 – X03</b>
• Pre-signal latching	Off	Off / On		<b>X01 – X03</b>
<b>Smoke sensor dust/soiling</b>				
• Smoke sensor dust On / Off	On	On / Off		<b>X01 – X03</b>
• Smoke sensor soiling On / Off	On	On / Off		<b>X01 – X03</b>
• Dust threshold (% of AI)	50 %	5 – 60 %	5 %	<b>X01 – X03</b>
• Soiling threshold (% of AI)	75 %	65 – 100 %	5 %	<b>X01 – X03</b>
• Dust latching	On	On / Off		<b>X01 – X03</b>
• Soiling latching	On	On / Off		<b>X01 – X03</b>
• Smoke sensor fault delay	30 s	0 s – 60 s	1 s	<b>X01 – X03</b>
<b>Airflow monitoring</b>				
• LS-Ü pipe blockage On / Off	On	On / Off		<b>X01 – X03</b>
• LS-Ü pipe breakage On / Off	On	On / Off		<b>X01 – X03</b>
• LS-Ü sensitivity (applies to <b>A01</b> to <b>C32</b> ) ①	±20% ①	±1 – ±70%	± 1%	<b>X01 – X03</b>
• LS-Ü value averaging (number)	20	1 – 30	1	<b>X01 – X03</b>
• LS-Ü delay (applies to <b>A01</b> to <b>C32</b> ) ①	300 s ①	10 s – 3600 s	1 s	<b>X01 – X03</b>



### Notice

① Stored under switch positions **W01** to **W48** are increased values which are not tested for EN compliance (see Sec. 4.4.4.4).

**Table B:** The following criteria apply to the entire ASD 533. Configuration changes are stored in connection with the adjustments from Table A, likewise on one of the user configurable switch positions **X01** to **X03**.

Sector • Parameter	Default setting	Area	Resolution / levels	Saving after change
<b>Autolearning</b>				
• Autolearning On / Off	Off	On		<b>X01 – X03</b>
• Autolearning duration	3 days	1 min to 14 days	min, h, days	<b>X01 – X03</b>
• Autolearning factor (of measured AI threshold)	1.5	1.1 – 10 x		<b>X01 – X03</b>
<b>Day/night control / weekday control</b>				
• Day/night control On / Off	Off	Off / clock / FACP / input "OEM1 / St"		<b>X01 – X03</b>
• Day start time (only with "Clock")	06:00	00:00 – 24:00	1 min	<b>X01 – X03</b>
• Night start time (only with "Clock")	20:00	00:00 – 24:00	1 min	<b>X01 – X03</b>
• Weekday control (only with "Clock")	On	Mon to Sun	Days	<b>X01 – X03</b>
<b>General faults</b>				
• Lithium battery / clock fault	On	On / Off		<b>X01 – X03</b>
<b>Fan</b>				
• Fan speed ASD 533-1	Level I	Level I		<b>X01 – X03</b>
• Fan speed ASD 533-2	Level II	Level II and I		
<b>Deactivate / switch off sensor</b>				
• Smoke sensor I / Smoke sensor II	On	On / deactivated / switched off (partial planning)		<b>X01 – X03</b>
• Switch off (partial planning) only smoke sensor II				

**Table C:** Independent configurations. These configurations can be changed independently of the switch position on the ASD 533.

Sector • Parameter	Default setting	Selection
<b>Time</b>		
• Year, month, day, hour, minute	---	Minutes – year
<b>Relay / OC output / reset key / various</b>		
• Relay 3 and OC output 3, AMB 33	Alarm II	according to Sec. 7.2.2
• Relay 1, 1 <sup>st</sup> RIM 35	Pre-signal 1 smoke sensor I	according to Sec. 7.2.2
• Relay 2, 1 <sup>st</sup> RIM 35	Pre-signal 2 smoke sensor I	according to Sec. 7.2.2
• Relay 3, 1 <sup>st</sup> RIM 35	Pre-signal 3 smoke sensor I	according to Sec. 7.2.2
• Relay 4, 1 <sup>st</sup> RIM 35	Smoke sensor I dirty	according to Sec. 7.2.2
• Relay 5, 1 <sup>st</sup> RIM 35	Sampling pipe I pipe blockage	according to Sec. 7.2.2
• Relay 1, 2 <sup>nd</sup> RIM 35	Pre-signal 1 smoke sensor II	according to Sec. 7.2.2
• Relay 2, 2 <sup>nd</sup> RIM 35	Pre-signal 2 smoke sensor II	according to Sec. 7.2.2
• Relay 3, 2 <sup>nd</sup> RIM 35	Pre-signal 3 smoke sensor II	according to Sec. 7.2.2
• Relay 4, 2 <sup>nd</sup> RIM 35	Smoke sensor II dirty	according to Sec. 7.2.2
• Relay 5, 2 <sup>nd</sup> RIM 35	Sampling pipe II pipe blockage	according to Sec. 7.2.2
• Reset key On / Off ①	On ①	On / Off
• Heating control, subsequent heating time	2 min	1 – 60 min
• MCM setting, recording interval	1 s	1 – 120 s
• MCM smoke peak value memory	Off	Off / On
• Carry out initial reset	---	On / Off
• Smoke sensor mode of operation (smoke sensor I / II)	SSD/DMB	SSD/DMB or OEM inputs I (individual or in combination) Switched off
• Isolate smoke sensor (smoke sensor I / II)	normal operation	isolate / normal operation
• Filtermonitoring (smoke sensor I / II)	Off	Off / On
• Filter service life	6 months	1 – 24 months
• Read out operation time	---	months / days
• Filter replacement	---	start / finish



### Notice

① In the Chinese market, the reset key on the device must be deactivated using the "ASD Config" configuration software.

# Commissioning

## 7.2.2 Relay allocation

The following criteria can be programmed on a maximum of 11 relays (1 AMB 33 on ASD 533-1, 5 units with 1<sup>st</sup> RIM 35, 5 units with 2<sup>nd</sup> RIM 35):

Smoke sensor I / LS-Ü I	Smoke sensor II / LS-Ü II	General
Alarm smoke sensor I	Alarm smoke sensor II	Fan fault
Pre-signal 1 smoke sensor I	Pre-signal 1 smoke sensor II	Operating voltage fault
Pre-signal 2 smoke sensor I	Pre-signal 2 smoke sensor II	Initial reset fault
Pre-signal 3 smoke sensor I	Pre-signal 3 smoke sensor II	Lithium battery / clock fault
Smoke sensor I dusty	Smoke sensor II dusty	
Smoke sensor I soiled	Smoke sensor II soiled	
Smoke sensor I fault	Smoke sensor II fault	
Pipe blockage sampling pipe I	Pipe blockage sampling pipe II	
Pipe breakage sampling pipe I	Pipe breakage sampling pipe II	
Heating control sampling pipe I	Heating control sampling pipe II	
Alarm 2 smoke sensor I	Alarm 2 smoke sensor II	

The criteria can also be allocated using the OR function (example: smoke sensor dust or soiling together on one relay).

## 7.3 Startup

The information on control and indicator elements necessary for startup can be found in **Fig. 41**.

### Notice

Before the ASD 533 is switched on, all the precautions required for operation as described in Sec. 7.1 must be fulfilled.

### 7.3.1 Commissioning using EasyConfig

The workflow for commissioning with [EasyConfig](#) is shown below (planning without “ASD PipeFlow” calculation, without “ASD Config” configuration software). When RIM 35 additional modules are fitted, the RIM relays respond as indicated in Sec. 2.2.6 and Sec. 7.2.1, Table C. The default values as set out in Sec. 7.2.1 also apply to all other settings.

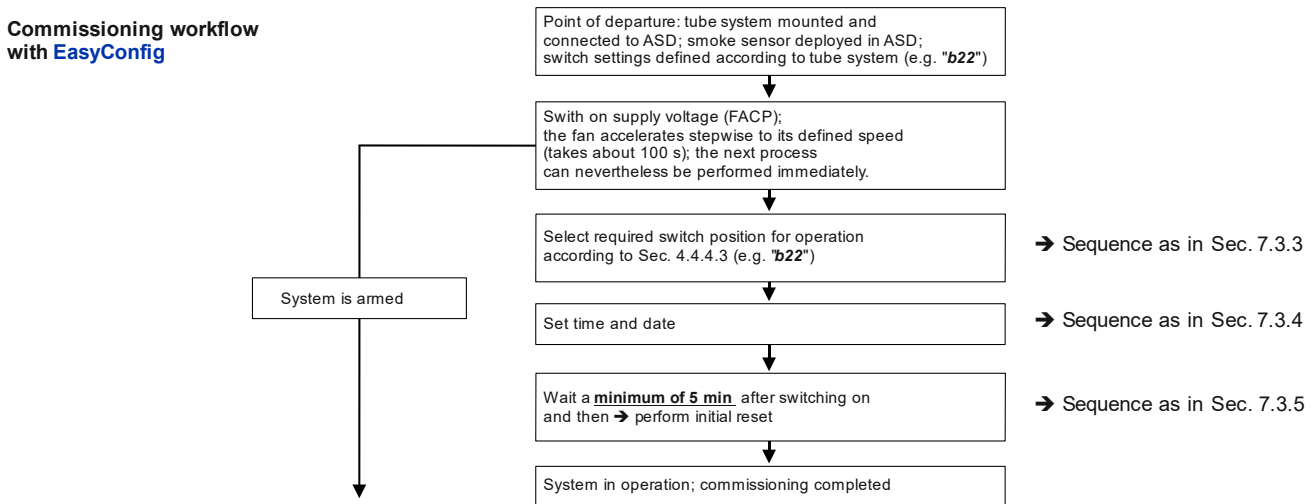

**Fig. 43 Workflow for commissioning using EasyConfig**

### 7.3.2 Commissioning with “ASD Config” configuration software

The workflow for commissioning when using the “ASD Config” configuration software is shown below. The “ASD Config” configuration software is required only if changes have to be made to the default configuration profile (Sec. 7.2.1) or if the “ASD PipeFlow” calculation software has been used.

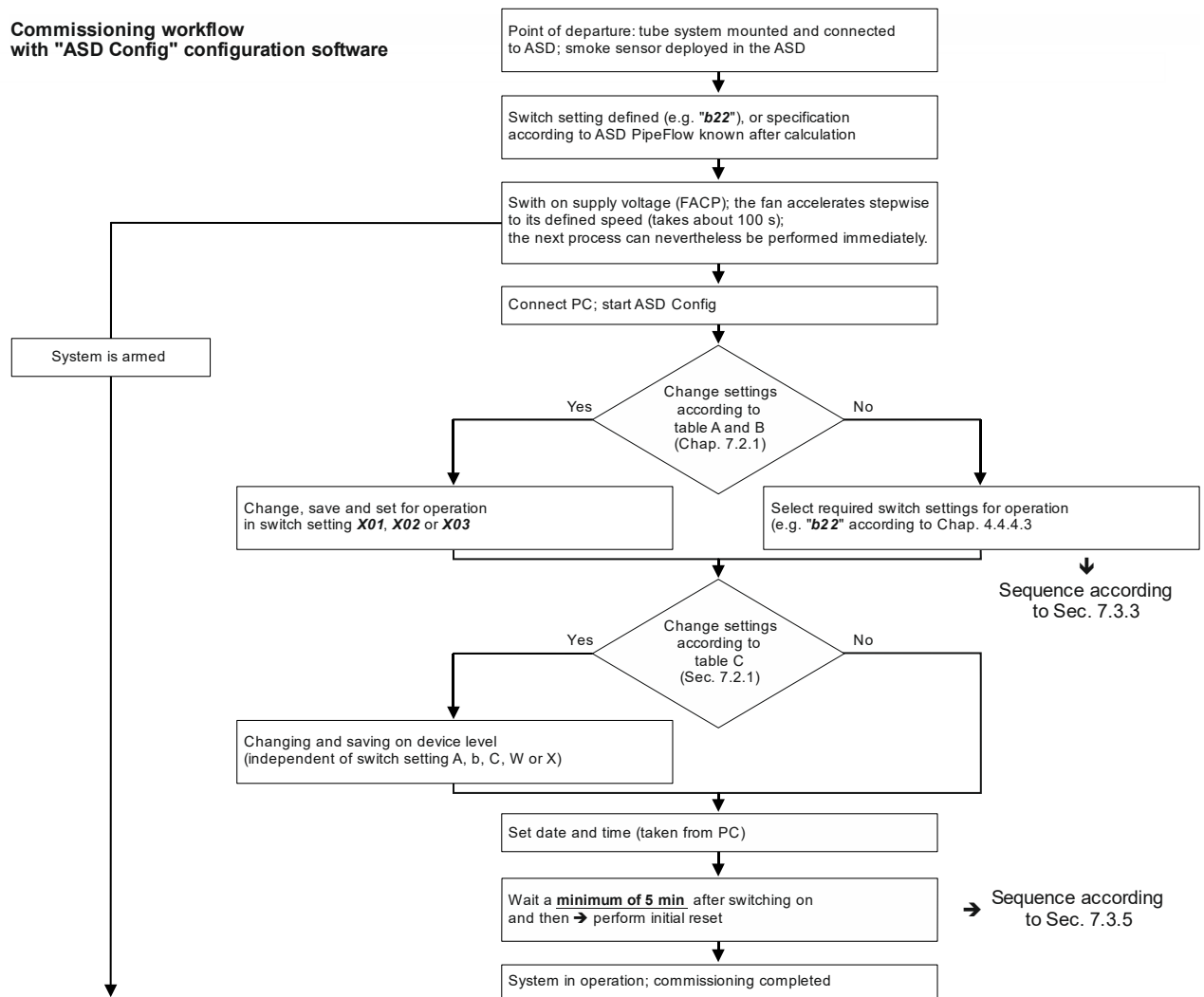

Fig. 44 Workflow for commissioning with “ASD Config” configuration software

## Commissioning

### 7.3.3 Setting to pre-defined switch positions A11 to C32, W01 to W48

The following describes the procedure for setting the ASD 533 to one of the switch positions with fixed parameters **A11** to **C32** and **W01** to **W48**.

**Example:** The ASD 533 is to respond in compliance with EN 54-20, Class B. The sampling pipe is U-shaped, within system limit 2. According to Sec. 4.4.4.3 switch position **b22** is to be selected.



#### Notice

Switch positions **W01** to **W48** are to be used only after prior consultation with the manufacturer. The airflow monitoring values stored under those switch positions are **not** tested in accordance with EN.

Measure	Display	Procedure / remarks
(1)  Press key	flashing <b>C32</b>	• Displays the default setting
(2)  Press the key again until the display is on <b>b</b>	in succession <b>A / b</b>	• Displays the switch position group <b>b</b>
(3)  Press key	<b>b11</b>	• Displays the smallest possible switch position in group <b>b</b>
(4)  Press the key until the display is on <b>b22</b>	alternating <b>b11 / b12 / b21 / b22</b>	• Displays the possible switch positions in group <b>b</b>
(5)  Press key	flashing <b>b - -</b> (approx. 4 x)	• New setting is programmed
(6)  Press the key to check the change	flashing <b>b22</b>	• Displays the new setting

### 7.3.4 Setting and polling the date and time

The following describes the procedure for setting the date and time. **Example:** Setting to 10 June 2016; 11:05:30

Measure	Display	Procedure / remarks
(1)  Press key	flashing <b>C32</b> or other	• Displays the default setting or the installation-specific switch position as described in Sec. 4.4.4.3
(2)  Press the key again until the display is on <b>T</b>	in succession <b>A / b / C / d / E / F / I / o / T</b>	• Displays the switch position group <b>T</b>
(3)  Press key	<b>RE</b> ①	• Date/time display, polling mode ①
(4)  Press the key until the display is on <b>SE</b>	in succession <b>RE / SE</b>	• Date/time display, input mode
(5)  Press key > Year	<b>Y13</b>	• Displays the year 2013 (example)
(6)  Press the key until <b>Y16</b>	<b>Y16</b>	• Selected year 2016
(7)  Press key > Month	<b>M01</b>	• Displays the month of January
(8)  Press the key until <b>M06</b>	<b>M06</b>	• Selected month June
(9)  Press key > Day	<b>d01</b>	• Displays the first day of the month
(10)  Press the key until <b>d10</b>	<b>d10</b>	• Selected day is 10
(11)  Press key > Hour	<b>H00</b>	• Displays hour 00
(12)  Press the key until <b>H11</b>	<b>H11</b>	• Selected hour is 11
(13)  Press key > Minute	<b>M00</b>	• Displays minute 00
(14)  Press the key until <b>M05</b>	<b>M05</b>	• Selected minute is 05
(15)  Press key > Second	<b>S00</b>	• Displays second 00
(16)  Press the key until <b>S30</b>	<b>S30</b>	• Selected second is 30
(17)  Press the key, date and time are programmed	Flashing <b>T - -</b> (approx. 4 x)	• The date is set to 10.06.2016, and the clock starts to run from the time 11:05:30



#### Notice

##### ① Poll date and time:

In the **T > RE** switch position, pressing "OK" outputs the currently set date and the current time on the ASD 533.

**Example:** In sequence **Y16 > M06 > d10 > H11 > M05 > S57**.





### 7.3.5 Initial reset

When commissioning the ASD 533, an initial reset is required. When this happens, the airflow monitoring is automatically aligned to the connected sampling pipe(s).

**Notices**





- In principle the initial reset should be carried out under “normal system conditions”, i.e. with any ventilation systems, air conditioning systems, etc., running in “normal operation”.
- If a maintenance sampling hole is provided, it must be closed with adhesive tape or the maintenance clip.
- The initial reset must be performed with normal ventilation for equipment monitoring of ventilated objects.
- If there is an expansion, conversion, retrofitting or repair on the sampling pipe, an initial reset is imperative.
- ASD 533-2; an initial reset must be performed after the fan speed has been changed.
- After a firmware upgrade, an initial reset is required only if expressly mentioned in the relevant firmware description.
- Before carrying out an initial reset – i.e. after switching on the ASD 533 – it is imperative to observe a **waiting time of at least 5 min.**

Measure	Display	Procedure / remarks
(1)  Press key	flashing <b>C32</b> or other	<ul style="list-style-type: none"> <li>Displays the default setting or the installation-specific switch position as described in Sec. 4.4.4.3</li> </ul>
(2)  Press the key again until the display is on <b>U</b>	in succession <b>A / b / C / d / E / F / I / o / T / U</b>	<ul style="list-style-type: none"> <li>Displays the switch position group <b>U</b></li> </ul>
(3)  Press key	<b>U01</b>	<ul style="list-style-type: none"> <li>Displays initial reset On</li> </ul>
(4)  Press the key again	flashing <b>U - -</b> (5 to max. 120 s)	<ul style="list-style-type: none"> <li>Initial reset in progress</li> </ul>
(5) Wait	flashing point (watchdog indicator)	<ul style="list-style-type: none"> <li>Initial reset completed</li> </ul>

### 7.3.6 Displaying the firmware version

On the ASD 533 the switch position **F** can be used to display the version of the firmware currently loaded.

Measure	Display	Procedure / remarks
(1)  Press key	flashing <b>C32</b> or other	<ul style="list-style-type: none"> <li>Displays the default setting or the installation-specific switch position as described in Sec. 4.4.4.3</li> </ul>
(2)  Press the key again until the display is on <b>F</b>	in succession <b>A / b / C / d / E / F</b>	<ul style="list-style-type: none"> <li>Displays the switch position group <b>F</b></li> </ul>
(3)  Press key	flashing after approx. 2 s, e.g. <b>F01</b> . Pause <b>F08</b> . Pause <b>F00</b>	<ul style="list-style-type: none"> <li>Displays the firmware version, in this case 01.08.00</li> </ul>





## 7.3.7 Logging off additional modules

The additional modules (XLM 35, ML-SFD, SLM 35, RIM 35, MCM 35, SIM 35, UIM 35) are automatically detected when the device is switched on; from that point onwards, they are monitored and fully functional. The MCM 35 begins logging data as soon as the SD memory card is inserted (indicated by the flashing red LED on the MCM). To read out the SD memory card or when subsequently removing an additional module (e.g. because it is not being used), the additional modules must first be logged off via operation on the AMB 33 Main Board.



### Notice

A time-out (approx. 15 s) is configured for the logoff procedure. During this time the additional modules can be electrically disconnected from the AMB 33 trouble-free or the SD memory card can be removed from the MCM. If no component is removed during that time (including removing the SD memory card), the additional modules are re-activated and data logging on the MCM continues.

Measure	Display	Procedure / remarks
(1)  Press key	flashing <b>C32</b> or other	<ul style="list-style-type: none"> <li>Displays the default setting or the installation-specific switch position as described in Sec. 4.4.4.3.</li> </ul>
(2)  Press the key again until the display is on <b>o</b>	in succession <b>A / b / C / d / E / F / I / o</b>	<ul style="list-style-type: none"> <li>Displays the switch position group <b>o</b></li> </ul>
(3)  Press key	<b>o00</b>	<ul style="list-style-type: none"> <li>Displays logoff additional module</li> </ul>
(4)  Press the key again	flashing <b>o - -</b> (timeout approx. 15 s)	<ul style="list-style-type: none"> <li>Start logoff procedure, duration approx. 15 s</li> </ul>
(5) Electrically disconnect (ribbon cable) the relevant additional module from the AMB 33 within the logoff time (15 s) or remove the SD memory card from the MCM.		<ul style="list-style-type: none"> <li>If the module is not electrically disconnected from the AMB 33 within 15 s (including removal of the SD memory card), it is re-activated and data logging continues on the MCM.</li> </ul>

## 7.4 Re-programming



### Notice

The ASD parameters are configured ex works with default states and values so that the triggering properties comply with EN 54-20. Changing the parameters may result in non-compliance with EN 54-20. Any adjustments or modifications to the ASD 533 using the “ASD Config” configuration software or the user interface on the FACP may only be carried out by the manufacturer or by qualified personnel trained by the manufacturer.

### 7.4.1 Re-programming on the ASD 533

If a different switch position has to be selected within the present system limits (**A11** to **C32** or **W01** to **W48**), the re-programming is carried out as set out in Sec. 7.3.3.

### 7.4.2 Re-programming with “ASD Config” configuration software

When changing parameters as described in Sec. 7.2.1 and 7.2.2, use the “ASD Config” configuration software.

### 7.4.3 Re-programming from SecuriPro / SecuriFire / Integral with SLM 35

When connecting to the SecuriPro, SecuriFire or Integral FACP via an SLM 35, limited re-programming of the ASD 533 can be carried out from the user interface of the FACP.



#### Notices

- When connecting from the SecuriPro, SecuriFire or Integral FACP, the commissioning must always take place on the ASD 533. It is not possible to carry out an initial reset from the FACP.
- Re-programming from the SecuriPro, SecuriFire or Integral FACP is possible only if the slide switch on the SLM 35 is in the “**BMZ**” position. If the switch is in the position “**ASD**”, the ASD is the Master, and only a status query can be carried out from the FACP (see also Sec. 8.5.5.1).
- Re-programming from the SecuriPro, SecuriFire or Integral FACP can only be carried out in the switch positions **X01** to **X03**.

The following criteria can be modified (take note of the switch position on SLM 35):

Criterion	Level	Corresponds to value in the ASD or (Ⓢ range from FACP)
Smoke sensor response sensitivity	high	80% of “medium”
	medium	corresponds to sensitivity for <b>A11</b> to <b>W48</b> or “ASD PipeFlow” (= 100 %)
	low ②	120% of “medium”
Sensitivity of the airflow monitoring	high	±10% (Ⓢ ±10%)
	medium	±20%, for <b>A11</b> to <b>C32</b>
	low ②	±50% (Ⓢ ±30 – ±70%)
Delay time for the airflow monitoring	high ②	20 min (Ⓢ 11 – 60 min)
	medium ②	10 min (Ⓢ 6 – 10 min)
	low	300 s, for <b>A11</b> to <b>C32</b> (Ⓢ 10 s – 300 s)
Restoring the factory settings	Default	Above criteria to default values
= Normative settings according to EN 54-20		



#### Notices

Subsequent re-programming on the ASD is possible.

- ① The sensitivity levels on the FACP user interface comprise a default value and a defined range with regard to the ASD configuration.

**Example:** After the ASD 533 is commissioned, the sensitivity of the airflow monitoring is set automatically to ±20% (default value, EN 54-20 compliant). If there is a subsequent re-programming from the FACP to level “low”, the ASD changes its configuration to ±50%. If further re-programming is subsequently carried out on the ASD using the “ASD Config” configuration software, e.g. to ±30%, the “low” level remains if the status is polled from the FACP (for the FACP ±30% is in the same range as ±50%). By contrast a change to ±10% on the ASD produces the “high” display on the FACP.

- ② Re-programming from the SecuriPro, SecuriFire or Integral FACP may result in non-compliance with EN 54-20. Any adjustments or modifications on the ASD 533 from the SecuriPro, SecuriFire or Integral FACP to the “low” level may only be carried out by the manufacturer or by qualified personnel trained by the manufacturer.

### 7.4.4 Re-programming from SecuriFire / Integral with XLM 35 / ML-SFD

When connecting to the SecuriFire or Integral FACP via an XLM 35 or ML-SFD control operations and changes can be made to the ASD device configuration directly from the FACP. For this purpose the FACP user software “SecuriFire-Studio” and “Integral [Application Centre](#)” is used to start the “ASD Config” configuration software for access to the ASDs, the configuration software then being used to make the changes to the ASD 533.

## 7.5 Uploading new firmware to the ASD 533

The firmware is stored on the **Flash** PROM in the ASD 533. Firmware is upgraded via the USB interface of the AMB 33 using the “ASD Config” configuration software. Selecting the corresponding firmware upgrade in the “ASD Config” calls up the “Flasher Tool” program. To upgrade the firmware, switch the **S4** switch on the AMB 33 in the ASD 533 to position “**P**” and press the “HW reset” key (see also **Fig. 41**).



### Notice

Pressing the “HW reset” key in switch position **S4 “P”** triggers the fault relay. So when upgrading firmware on the ASD 533 it is essential to switch off **fire incident controls and remote alerting** on superordinate systems (FACP) beforehand.

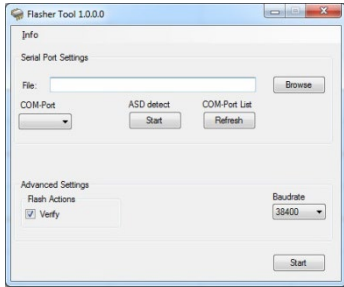
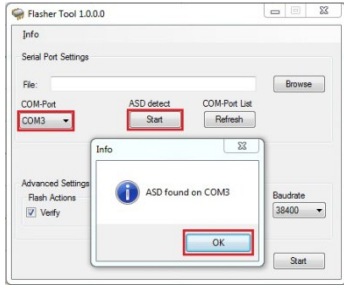
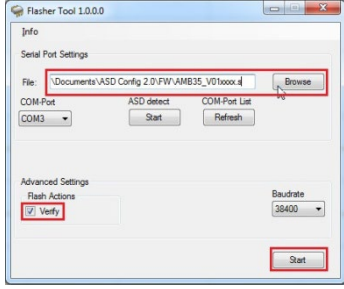
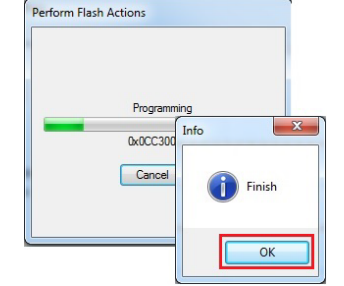
Measure	Display	Procedure / remarks
(1) On the AMB 33 switch the S4 switch to position “P”.		<ul style="list-style-type: none"> <li>Prepare ASD for firmware upgrade; ASD switches to <b>Program Mode</b>.</li> </ul>
(2) On the AMB 33, briefly press the “HW reset” key.	LED 2 on AMB 33 is continuously lit	<ul style="list-style-type: none"> <li>Display reads “Watchdog waits”</li> <li>ASD triggers fault</li> <li>Fan stops</li> <li>The segment display on the AMB 33 has an arbitrary state without meaning</li> </ul>
(3) Select “FW download” in “ASD Config”.		<ul style="list-style-type: none"> <li>“Flasher Tool” dialog box opens with the basic settings.</li> </ul>
(4) Select the command “ASD detect” (“Start”): <ul style="list-style-type: none"> <li>Under “COM Port” the <b>USB Serial Port</b> is automatically set to the connected ASD,</li> <li>Confirm the information message with “OK”.</li> </ul>		<ul style="list-style-type: none"> <li>Displays the required communication settings.</li> </ul>
(5) <ul style="list-style-type: none"> <li>Use “Browse” to find the folder where the new firmware is located;</li> <li>Select the file with the new firmware and click “Open”;</li> <li>Leave the check mark at “Verify” (default);</li> <li>Press the “Start” key.</li> </ul>		<ul style="list-style-type: none"> <li>Select the new firmware.</li> </ul>
(6) The upload to the ASD 533 begins. Once the upload is completed, the “Finish” information message appears; confirm with “OK”.		<ul style="list-style-type: none"> <li>Transmission duration approx. 150 s</li> <li>During the transmission, LEDs 5 and 6 flash on the AMB 33</li> </ul>



Continuation:

(7) On the AMB 33 switch the S4 switch to position "R".		<ul style="list-style-type: none"> <li>ASD is now back in <a href="#">Run Mode</a></li> </ul>
(8) On the AMB 33, briefly press the "HW reset" key.	LED 2 on AMB 33 goes out; the segment display flashes approx. 4 times to display the previously set switch position (e.g. <b>b22</b> ).	<ul style="list-style-type: none"> <li>Fan starts up</li> <li>Fault is reset</li> <li>ASD continues running with the previous installation-specific settings</li> <li>Firmware upgrade is completed</li> </ul>
(9) Carry out a new initial reset after waiting a minimum of 5 min from Item (7). <b>Attention:</b> this is required only if expressly mentioned in the relevant firmware description.	according to Sec. 7.3.5	<ul style="list-style-type: none"> <li>Take note of the firmware description for the uploaded firmware.</li> <li>according to Sec. 7.3.5</li> </ul>

## 7.6 Measurements

The ASD supply voltage on terminals 1 and 2 must be checked (check also terminals 3 and 4 in the case of a redundant supply). If the FACP voltage supply is correctly set (not emergency current operation), the voltage should range between 12.3 and 13.8 VDC (when operated in 12 VDC mode) or between 21.6 and 27.6 VDC (when operated in 24 VDC mode). The value depends on the line length. Once commissioning is completed, the measured voltage value is to be entered in the commissioning protocol (see Sec. 7.9).

With the conductor cross-section determined and installed as described in Sec. 4.9.2, this voltage range must always be available at the end of the electrical installation – i.e. at the ASD 533 – to ensure that the ASD 533 is able to operate fault-free (see also Sec. 4.9.2).











### Notices

- If the measured value is outside the aforementioned range, the ASD 533 may malfunction or even become damaged (over 30 VDC).
- Voltage values that are too low can be caused by insufficiently dimensioned conductor cross-sections or an incorrectly set FACP voltage.

## Commissioning

### 7.6.1 Reading out the set configuration and airflow

Besides the measurement of the supply voltage on the ASD 533, the set configuration (switch position selected at commissioning **A11** to **C32**, **W01** to **W48** according to Sec. 4.4.4.3 or parameter-based switch position **X01** to **X03**) and the airflow values (change in volume rate of flow from the time of the initial reset) are also to be recorded and logged in the commissioning protocol (see also Sec. 7.9).

Measure	Display / indication	Procedure / comment
(1)  Briefly press key	flashing, e.g. <b>b22</b> or other	<ul style="list-style-type: none"> <li>When commissioning, display of the switch settings <b>A11</b> to <b>C32</b>, <b>W01</b> to <b>W48</b>, <b>X01</b> to <b>X03</b></li> </ul>
(2)  Press the key again until the display is on <b>V</b>	in succession <b>A / b / C / d / E / F / I / o / T / U / V</b>	<ul style="list-style-type: none"> <li>Displays the switch position group <b>V</b></li> </ul>
(3)  Press key	<b>V01</b>	<ul style="list-style-type: none"> <li>Selects the volume rate of flow measurement for sampling pipe I</li> </ul>
(4)  Press the key again	flashing after approx. 2 s, e.g. <b>099</b>	<ul style="list-style-type: none"> <li>Display airflow for sampling pipe I = 99 % of initial reset (initial reset = 100 %)</li> </ul>
(5)  <b>for ASD 533-2:</b> Press the key again until the display is on <b>V</b>	in succession <b>A / b / C / d / E / F / I / o / T / U / V</b>	<ul style="list-style-type: none"> <li>Displays the switch position group <b>V</b></li> </ul>
(6)  Press key	<b>V01</b>	<ul style="list-style-type: none"> <li>Selects the volume rate of flow measurement for sampling pipe I</li> </ul>
(7)  Press key	<b>V02</b>	<ul style="list-style-type: none"> <li>Selects the volume rate of flow measurement for sampling pipe II</li> </ul>
(8)  Press key	flashing after approx. 2 s, e.g. <b>098</b>	<ul style="list-style-type: none"> <li>Display airflow for sampling pipe II = 98 % of initial reset (initial reset = 100 %)</li> </ul>

**Meaning:** Value < 100% = direction pipe blockage / > 100% = direction pipe breakage



#### Notice

According to EN 54-20 a change in the airflow that is greater than  $\pm 20\%$  must be reported as a fault. In the ASD 533 aspirating smoke detector the airflow in a correct and clean sampling pipe is indicated as 100% after an initial reset. In switch positions **A11** to **C32** a fault is triggered if the change in value is greater than  $\pm 20\%$  – i.e. below 80% or above 120% – and the LS-Ü delay time of 300 s has expired.

## 7.7 Testing and checking

In addition to the sampling pipe checks set out in Sec. 7.1, the correct transmission of alarms (zone/line) on the FACP is to be checked by triggering faults or alarms on the ASD 533. These tests are to be entered in the commissioning protocol (see also Sec. 7.9).



### Notice

Block or deactivate fire incident control and remote alerting on the superordinate FACP.

- ① Between each check reset the ASD 533 (preferably on the FACP as a reset on the ASD does not reset the FACP). Likewise, after the tests, restore the original state of the sampling pipe (re-open taped-up sampling holes, seal maintenance sampling holes).
- ② For the ASD 533-2 checks have to be carried out for both sampling pipes.

Alternatively, this control can also be performed using the “Test trigger” function from *EasyConfig* (see Sec. 7.7.2).

Test event	Procedure	Action
Checking the airflow monitoring ① / ②	Tape up the sampling holes (adhesive tape); number depends on the pipe configuration	<ul style="list-style-type: none"> <li>• As soon as the resulting change in the volume rate of flow exceeds <math>\pm 20\%</math> (which can also be checked using switch position <b>V</b> according to Sec. 7.6.1), the “Fault” LED begins to flash.</li> <li>• When the LS-Ü delay expires (300 s), the ASD triggers a fault → fault on FACP.</li> </ul>
Checking the alarm release ① / ②	Apply smoke to maintenance sampling hole or sampling hole, see Sec. 7.7.1.	<ul style="list-style-type: none"> <li>• ASD triggers an alarm → alarm on FACP; check correct alarm transmission (zone/area triggering) on the FACP.</li> <li>• If there are pre-signals they are also actuated</li> </ul>

### 7.7.1 Checking the alarm release

When **commissioning** and after any changes (repairs) to the sampling pipe the alarm release must take place from the **last sampling hole** on each pipe branch. This tests the uniformity throughout the entire sampling pipe.

To check the alarm release during ordinary **maintenance and servicing work** the ASD 533 can be made to respond via the **maintenance sampling hole**. As the sampling pipe is continuously monitored for proper functioning, testing via the sampling pipe is normally not necessary. Once the test is completed, re-seal the maintenance sampling hole (using adhesive tape or maintenance clip).

If testing via the maintenance sampling hole is inadequate, testing can be carried out via the sampling pipe as follows:

- Point-by-point testing of the sampling holes; apply smoke directly to individual or several sampling holes. Apiarist smoke or wax/joss sticks are suitable for this purpose.
- Area-wide testing of the sampling pipe; area-wide testing of the sampling pipe using fire tests is reasonable and practicable only following EN 54-20.



### Notice

If genuine fire tests are to be carried out, the relevant local authorities (fire service) are to be consulted beforehand; the tests themselves are to be carried out by trained specialists (manufacturer) only.

## 7.7.2 Test triggerings



### Notice about test triggerings

**Fire incident control** and remote alerting must be blocked or deactivated on the superordinate FACP.

















The “**Test pre-signal**” and “**Test alarm 2**” functions can also be triggered with a non-parameterised event.

- ① Reset the ASD 533 between each check (preferably on the FACP, as a reset on the ASD does not reset the FACP).
- ② On the ASD 533-2 the checks for both smoke sensors (channels) have to be carried out. On ASD 533-1, steps **(5)** to **(8)**, **(13)** to **(16)**, **(21)** to **(24)** and **(29)** to **(32)** do not appear in the workflow.

Measure	Display	Procedure / remarks
(1)  Press key	flashing <b>C32</b> or other	• Displays the default setting or the installation-specific switch position
(2) <b>Test alarm channel I</b> Press the key again until the display is on <b>I</b>	in succession <b>A / b / C / d / E / F / I</b>	• Displays switch position group <b>I</b>
(3)  Press key > <b>IA1</b>	<b>IA1</b> (possible selection here: <b>IA1 / IA2 / IF1 / IF2 / IP1 / IP2 / IE1 / IE2</b> )	• Displays test mode “Test alarm from <i>EasyConfig</i> ”
(4)  Press key <b>3 x</b>	flashing <b>IA1</b> (until reset)	• ASD 533 triggers Alarm I → via relay or XLM / ML-SFD to FACP → reset from FACP ①
(5) ② <b>Test alarm channel II</b> Press the key several times until display on <b>I</b>	in succession <b>A / b / C / d / E / F / I</b>	• Displays switch position group <b>I</b>
(6)  Press key	<b>IA1</b>	• Displays test mode “Test alarm from <i>EasyConfig</i> ” for <b>channel I</b>
(7)  Press the key again until the display is on <b>IA2</b>	in succession <b>IA1 / IA2</b>	• Displays test mode “Test alarm from <i>EasyConfig</i> ” for <b>channel II</b>
(8)  Press key <b>3 x</b>	flashing <b>IA2</b> (until reset)	• ASD 533 triggers Alarm II → via relay or XLM / ML-SFD to FACP → reset from FACP ①
(9) <b>Test fault channel I</b> Press key again until display on <b>I</b>	in succession <b>A / b / C / d / E / F / I</b>	• Displays switch position group <b>I</b>
(10)  Press key	<b>IA1</b>	• Displays test mode “Test alarm from <i>EasyConfig</i> ” for <b>channel I</b>
(11)  Press the key several times until display on <b>IF1</b>	in succession <b>IA1 / IA2 / IF1</b>	• Displays test mode “Test alarm from <i>EasyConfig</i> ” for <b>channel I</b>
(12)  Press key <b>3 x</b>	flashing <b>IF1</b> (until reset)	• ASD 533 triggers fault → via relay or XLM / ML-SFD to FACP → reset from FACP ①
(13) <b>Test fault channel II</b> Press key again until display on <b>I</b>	in succession <b>A / b / C / d / E / F / I</b>	• Displays switch position group <b>I</b>
(14)  Press key	<b>IA1</b>	• Displays test mode “Test alarm from <i>EasyConfig</i> ” for <b>channel I</b>
(15)  Press the key several times until display on <b>IF2</b>	in succession <b>IA1 / IA2 / IF1 / IF2</b>	• Displays test mode “Test alarm from <i>EasyConfig</i> ” for <b>channel II</b>
(16)  Press key <b>3 x</b>	flashing <b>IF2</b> (until reset)	• ASD 533 triggers fault → via relay or XLM / ML-SFD to FACP → reset from FACP ①























Continuation:

Measure	Display	Procedure / remarks
(17)  <b>Test pre-signal channel I</b> Press key again until display on <b>I</b>	in succession <b>A / b / C / d / E / F / I</b>	<ul style="list-style-type: none"> <li>Displays switch position group <b>I</b></li> </ul>
(18)  Press key	<b>IA1</b>	<ul style="list-style-type: none"> <li>Displays test mode "Test alarm from <i>EasyConfig</i>" for <b>channel I</b></li> </ul>
(19)  Press the key several times until display on <b>IP1</b>	in succession <b>IA1 / IA2 / IF1 / IF2 / IP1</b>	<ul style="list-style-type: none"> <li>Displays test mode "Test pre-signal from <i>EasyConfig</i>" for <b>channel I</b></li> </ul>
(20)  Press key <b>3 x</b>	flashing <b>IP1</b> (until reset)	<ul style="list-style-type: none"> <li>ASD 533 triggers pre-signal → via relay or XLM / ML-SFD to FACP → reset from FACP ①</li> </ul>
(21)  <b>Test pre-signal channel II</b> Press key again until display on <b>I</b>	in succession <b>A / b / C / d / E / F / I</b>	<ul style="list-style-type: none"> <li>Displays switch position group <b>I</b></li> </ul>
(22)  Press key	<b>IA1</b>	<ul style="list-style-type: none"> <li>Displays test mode "Test alarm from <i>EasyConfig</i>" for <b>channel I</b></li> </ul>
(23)  Press the key several times until display on <b>IP2</b>	in succession <b>IA1 / IA2 / IF1 / IF2 / IP1 / IP2</b>	<ul style="list-style-type: none"> <li>Displays test mode "Test pre-signal from <i>EasyConfig</i>" for <b>channel II</b></li> </ul>
(24)  Press key <b>3 x</b>	flashing <b>IP2</b> (until reset)	<ul style="list-style-type: none"> <li>ASD 533 triggers pre-signal → via relay or XLM / ML-SFD to FACP → reset from FACP ①</li> </ul>
(25)  <b>Test alarm 2 channel I</b> Press key again until display on <b>I</b>	in succession <b>A / b / C / d / E / F / I</b>	<ul style="list-style-type: none"> <li>Displays switch position group <b>I</b></li> </ul>
(26)  Press key	<b>IA1</b>	<ul style="list-style-type: none"> <li>Displays test mode "Test alarm from <i>EasyConfig</i>" for <b>channel I</b></li> </ul>
(27)  Press the key several times until display on <b>IE1</b>	in succession <b>IA1 / IA2 / IF1 / IF2 / IP1 / IE1</b>	<ul style="list-style-type: none"> <li>Displays test mode "Test alarm 2 from <i>EasyConfig</i>" for <b>channel I</b></li> </ul>
(28)  Press key <b>3 x</b>	flashing <b>IE1</b> (until reset)	<ul style="list-style-type: none"> <li>ASD 533 triggers Alarm 2 → via relay or XLM / ML-SFD to FACP → reset from FACP ①</li> </ul>
(29)  <b>Test alarm 2 channel II</b> Press key again until display on <b>I</b>	in succession <b>A / b / C / d / E / F / I</b>	<ul style="list-style-type: none"> <li>Displays switch position group <b>I</b></li> </ul>
(30)  Press key	<b>IA1</b>	<ul style="list-style-type: none"> <li>Displays test mode "Test alarm from <i>EasyConfig</i>" for <b>channel I</b></li> </ul>
(31)  Press the key several times until display on <b>IE2</b>	in succession <b>IA1 / IA2 / IF1 / IF2 / IP1 / IE1 / IE2</b>	<ul style="list-style-type: none"> <li>Displays test mode "Test alarm 2 from <i>EasyConfig</i>" for <b>channel II</b></li> </ul>
(32)  Press key <b>3 x</b>	flashing <b>IE2</b> (until reset)	<ul style="list-style-type: none"> <li>ASD 533 triggers Alarm 2 → via relay or XLM / ML-SFD to FACP → reset from FACP ①</li> </ul>

## 7.8 Filter monitoring operation

The following filter monitoring operations are available on the ASD 533 (see also Sec. 2.2.18):









- Filter monitoring On/Off;
- Change filter service life (in months, 1 – 24) / read out filter service life (configured and expired);
- Start filter replacement (also possible via the “Reset” key) / finish filter replacement (“Reset”).

 <b>Notice</b> To prevent false alarms, the aspirating smoke detector is set to “Isolate” when filter replacement is active.		
Measure	Display	Procedure / remarks
(1)  <b>Filter monitoring On/Off</b> Example for channel I “On” Press key until display on <b>d</b>	in succession <b>A / b / C / d</b>	• Displays switch position group <b>d</b>
(2)  Press key > <b>RE</b>	<b>RE</b>	• Displays <b>RE</b> polling mode
(3)  Press key until display on <b>SE</b>	in succession <b>RE / SE</b>	• Displays <b>SE</b> input mode
(4)  Press key > <b>on</b>	<b>on</b> (possible selection here: <b>on / T / R / oFF</b> )	• Display <b>on</b> filter monitoring “On”
(5)  Press key > <b>b</b> ①	<b>b</b> (possible selection here: <b>b / ch1 / ch2</b> ) ①	• Display <b>b</b> “both channels” ( <b>b</b> und <b>ch2</b> are not available for selection on the ASD 533-1)
(6)  Press key until display on <b>ch1</b> ①	in succession <b>b / ch1</b> ①	• Displays <b>ch1</b> for <b>channel I</b>
(7)  Press key	flashing - - - (ca. 3 x)	• Filter monitoring is switched on
(1)  <b>Read out filter service life</b> Press key until display on <b>d</b>	in succession <b>A / b / C / d</b>	• Displays switch position group <b>d</b>
(2)  Press key > <b>RE</b>	<b>RE</b>	• Displays <b>RE</b> polling mode
(3)  Press key again Output for channel I	In sequence: <b>ch1</b> output for channel I <b>on</b> filter monitoring is “On” <b>T06</b> Filter service life = 6 months <b>R</b> last filter replacement <b>Y16</b> year 2016 <b>M10</b> month October <b>d31</b> day 31 <b>o10</b> operating time in month	• 6 months = default, range = 1 – 24 months  • 0 – 24, less than 10 = rounded off to 0.5 months
Output for channel II	<b>ch2</b> output for channel II <b>oFF</b> filter monitoring is “Off”	• Example on the filter monitoring <b>Channel II</b> “Off”, otherwise the procedure is the same as for <b>Channel I</b>
(1)  <b>Change filter service life</b> Example 12 months / channel I Press key until display on <b>d</b>	in succession <b>A / b / C / d</b>	• Displays switch position group <b>d</b>
(2)  Press key > <b>RE</b>	<b>RE</b>	• Displays <b>RE</b> polling mode
(3)  Press key until display on <b>SE</b>	in succession <b>RE / SE</b>	• Displays <b>SE</b> input mode
(4)  Press key > <b>SE</b>	<b>on</b> (possible selection here: <b>on / T / R / oFF</b> )	• Displays <b>on</b> filter monitoring “On”
(5)  Press key until display on <b>T</b>	in succession <b>on / T</b>	• Displays <b>T</b> filter service life
(6)  Press key > <b>b</b> ①	<b>b</b> (possible selection here: <b>b / ch1 / ch2</b> ) ①	• Displays <b>b</b> filter monitoring “both channels”
(7)  Press key until display on <b>ch1</b> ①	in succession <b>b / ch1</b> ①	• Displays <b>ch1</b> for <b>channel I</b>
(8)  Press key > <b>T06</b>	<b>T06</b>	• Displays 6 months (default)
(9)  Press key until display on <b>T12</b>	in succession <b>T01 to T24</b>	• Displays filter service life in months
(10)  Press key, program new filter service life	flashing - - - (ca. 3 x)	• The filter service life for <b>channel I</b> is programmed for 12 months

① **b** and **ch2** are not available for selection on ASD 533-1 (1-channel device).



Continuation:

Measure	Display	Procedure / remarks
(1)  <b>Start filter replacement</b> ① Example for channel I ② Press key until display on <b>d</b>	in succession <b>A / b / C / d</b>	<ul style="list-style-type: none"> <li>Displays switch position group <b>d</b></li> </ul>
(2)  Press key > <b>RE</b>	<b>RE</b>	<ul style="list-style-type: none"> <li>Displays <b>RE</b> polling mode</li> </ul>
(3)  Press key until display on <b>SE</b>	in succession <b>RE / SE</b>	<ul style="list-style-type: none"> <li>Displays <b>SE</b> input mode</li> </ul>
(4)  Press key > <b>SE</b>	<b>on</b> (possible selection here: <b>on / T / R / oFF</b> )	<ul style="list-style-type: none"> <li>Displays <b>on</b> filter monitoring "On"</li> </ul>
(5)  Press key until display on <b>R</b>	in succession <b>on / T / R</b>	<ul style="list-style-type: none"> <li>Displays <b>R</b> filter replacement</li> </ul>
(6)  Press key > <b>b</b> ①	<b>b</b> (possible selection here: <b>b / ch1 / ch2</b> ) ①	<ul style="list-style-type: none"> <li>Displays <b>b</b> filter monitoring "both channels"</li> </ul>
(7)  Press key > <b>ch1</b> ①	in succession <b>b / ch1</b> ①	<ul style="list-style-type: none"> <li>Displays <b>ch1</b> for <b>channel I</b></li> </ul>
(8)  Press key > <b>.Fr</b>	flashing <b>.Fr</b>	<ul style="list-style-type: none"> <li>Displays <b>.Fr</b> "Filter replacement started"</li> <li>ASD smoke sensor I is "isolated"</li> <li>ASD triggers fault</li> <li>"Fault" LED is lit</li> <li>Filter service life is set to "0"</li> </ul>
(9) Open dust filter unit and replace dirty filter element with clean replacement filter element. Afterwards, close the dust filter unit.	flashing <b>.Fr</b>	<ul style="list-style-type: none"> <li>The date of the replacement must be entered on the new replacement filter element or in the commissioning log.</li> </ul>
(10) Press "Reset" on the ASD.	Displays <b>.Fr</b> no lit	<ul style="list-style-type: none"> <li>Filter replacement is completed</li> <li>Fault is reset</li> <li>Isolation is removed</li> </ul>

① **b** and **ch2** are not available for selection on ASD 533-1 (1-channel device).

② Also, when the ASD 533 housing is closed, the "Start filter replacement" function can be activated by means of the "**Reset**" key. To do so, press the key **longer than 15 s** (attention: lamp test after 10 s). After 15 s the filter replacement is started and indicated by switching to the "Isolate" state (Fault and LED "**Fault**"). On an ASD 533-2 (2-channel devices) the filter replacement is started simultaneously for both smoke sensors (only if the filter monitoring is activated for both channels / smoke sensors). The filter replacement is completed by pressing the "Reset" key again. When the "Reset" key is deactivated (via "ASD Config"), the "Start filter replacement" function is not accessible.

## 7.9 Commissioning protocol

The ASD 533 ships with a commissioning protocol (fold-out) included in the scope of delivery. All of the measurements and tests carried out during commissioning and maintenance are to be entered on the protocol, which is then signed.



### Notices

- When maintenance work is carried out or after certain other events, conclusions can then be drawn concerning the commissioning state of the ASD 533 based on the commissioning protocol. The protocol also serves as a kind of life history of the ASD 533.
- The commissioning protocol is to be filled out conscientiously and fully and stored in the ASD 533. If required, a copy can be made and stored in the installation dossier.

## 8 Operation

### 8.1 Control and indicator elements

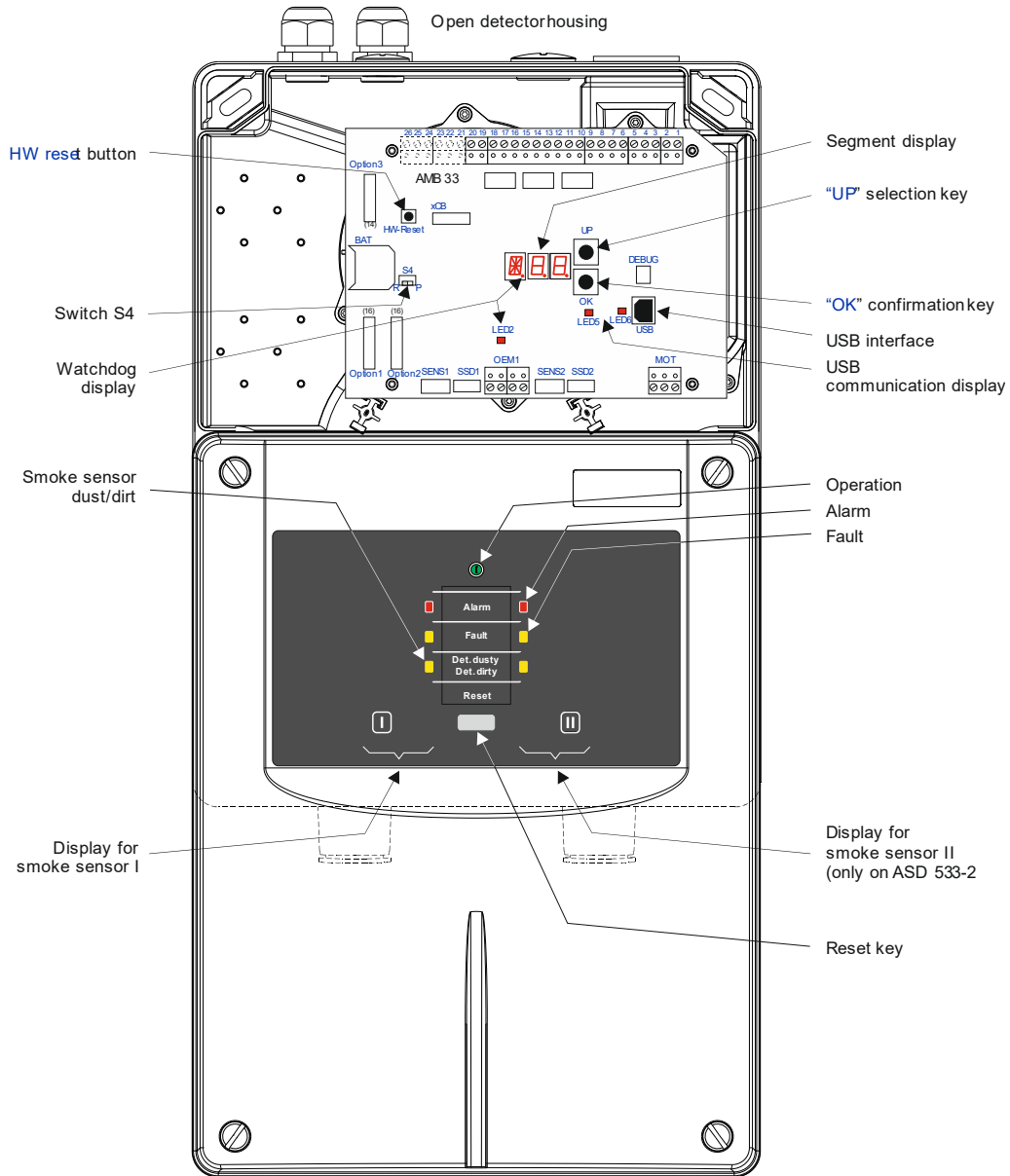

**Fig. 45 View of the control and indicator elements**

The control unit has a “Reset” key for resetting triggered events (alarms/faults) directly on the ASD 533. If the “Reset” key is pressed longer than 10 s, all indicators flash together on the control unit as “lamp test”.

Two 7-segment displays, an alphanumeric display, and two pushbuttons (“UP” / “OK”) are fitted to the AMB 33 Main Board inside the device.

## 8.2 Functional sequence of operation

The operation of the ASD 533 aspirating smoke detector in normal mode (after commissioning) is limited to switching on/off or to resetting a triggered event (alarm/fault). Operation is generally by means of the FACP, with input of the “Zone On/Off” and “Reset” functions (on “Reset external” input of the ASD 533).

Events triggered on the ASD 533 can be reset locally using the “Reset” key on the control unit or by briefly actuating the “Reset External” input. The reset is possible only if the triggered event is no longer pending (e.g. smoke sensor no longer has smoke). Imposing a continuous signal at the “Reset external” input also deactivates (switches off) the ASD 533 (see also Sec. 2.2.8 and 6.6.2).



### Notice

A local reset does not reset a higher-order FACP. The superordinate line of the FACP may trigger a fault as a result of the reset process on the ASD 533.

Two 7-segment displays, an alphanumeric display, and two pushbuttons (“UP” and “OK”) are fitted to the AMB 33 Main Board inside the device for the purpose of commissioning the ASD 533. These elements provide a type of rotary switch function, i.e. displays and positions in the range **A00** to **Z99** may appear.

The ASD 533 is commissioned using these elements. Device settings for predefined system limits can also be called up – **EasyConfig**. These pre-defined positions are stored with normative values for response sensitivity, airflow monitoring (LS-Ü) and pipe configuration. They also contain positions which allow deviations from the normative limits with regard to airflow monitoring. The **EasyConfig** process allows the device to be commissioned without the “ASD Config” software. If system-specific programming has to be carried out (e.g. after a calculation with “ASD PipeFlow” or when programming RIM 35), the “ASD Config” configuration software must be used.

## 8.3 Switch positions

Listed below are the switch positions which can be called up via the segment display and the “UP” / “OK” pushbuttons on the AMB 33. The switch positions can be used for inputs (**A / b / C / d / I / o / T / U / W / X**) or for polling purposes (**E / F / V**).

Stored under the rotary switch procedure is a **time-out** (approx. 5 s). If within this time period a process is not continued or completed, it is interrupted and the segment display automatically returns to the normal state (flashing point).

Pos.	Area / Display	Purpose	Meaning / Procedure ①
<b>A</b>	<b>A11 / A12</b>	Normative system limits compliant with EN 54-20, Class A	see Sec. 4.4.4.3 and 7.3.3
<b>b</b>	<b>b11 / b12 / b21 / b22</b>	Normative system limits compliant with EN 54-20, Class B	see Sec. 4.4.4.3 and 7.3.3
<b>C</b>	<b>C11 / C12 / C21 / C22 / C31 / C32</b>	Normative system limits compliant with EN 54-20, Class C	see Sec. 4.4.4.3 and 7.3.3
<b>d</b>	Polling ( <b>Read = RE</b> ) Setting ( <b>Set = SE</b> ) ↳ <b>on / T / R / oFF</b>	<b>on</b> = On / <b>oFF</b> = Off <b>T</b> = Time, filter service life <b>R</b> = Filter Replacement <b>ch1</b> = channel I	see Sec. 7.8
<b>E</b>	<b>E01 to E99</b> ↳ <b>G00 to G99</b>	Event memory, 99 events ( <b>E01</b> = last event) ↳ Event group <b>G00 to G99</b>	see Sec. 8.5.3
<b>F</b>	<b>F00 to F99</b> (3 x)	Displays the firmware version	see Sec. 7.3.6
<b>I</b>	<b>IA1 / IA2</b> <b>IF1 / IF2</b> <b>IP1 / IP2</b> <b>IE1 / IE2</b>	<b>Trigger (Initiate)</b> ; Test alarm ( <b>IA1</b> ), up to the FACP Test fault ( <b>IF1</b> ), up to the FACP Test pre-signal ( <b>IP1</b> ), up to the FACP Test Alarm 2 ( <b>IE1</b> ), up to the FACP Smoke sensor I ( <b>..1</b> ), smoke sensor II ( <b>..2</b> )	see Sec. 7.7.2
<b>o</b>	<b>o00</b>	Logs off the additional modules (optional modules) (all at once)	see Sec. 7.3.7
<b>T</b>	<b>Y10 to Y99 / M01 to M12</b> <b>d01 to d31 / H00 to H23</b> <b>M00 to M59</b>	Poll ( <b>Read = RE</b> ) and adjust ( <b>Set = SE</b> ) the date and time	see Sec. 7.3.4
<b>U</b>	<b>U01</b>	Executes initial reset	see Sec. 7.3.5
<b>V</b>	<b>V01 / V02</b> , from <b>000 to 255</b>	Volume flow output in % tube I (=V01), tube II (=V02)	see Sec. 7.6.1
<b>W</b>	<b>W01 to W48</b>	Non-normative system limits	see Sec. 4.4.4.4 and 7.3.3
<b>X</b>	<b>X01 to X03</b>	Configurable switch settings	see Sec. 7.2.1



### Notice

① The table merely lists the available switch positions. A detailed description of the operator functions (input procedure) can be found in the relevant chapter (“Meaning / Procedure” column).

## 8.4 Resetting

The ASD 533 can be reset after a triggered event by:

- Pressing the “Reset” pushbutton locally on the ASD or
- Briefly actuating the “External reset” input on the ASD.



### Notices

- Resetting can be triggered only after an event, but only if the criterion that resulted in the event trigger is back in its normal state (e.g. smoke level in the smoke sensor is once again below the trigger threshold, or a fault event is rectified). The ASD 533 continues to run “normally” after a reset and the fan does not stop.
- Local resetting (“Reset” key) does not reset a superordinate FACP. The superordinate line of the FACP may trigger a fault as a result of the reset process on the ASD 533.

## 8.5 Displays

### 8.5.1 Displays on the control unit

Several LEDs on the control unit indicate the current state of the ASD 533. The table below lists only the states for the ASD 533-1 (one smoke sensor / one sampling pipe). For the ASD 533-2 the indicators are doubled (I and II, see **Fig. 45**), except the operation indicator.

Function / state	Display			
	Operation	Alarm	Fault	Det. dusty Det. dirty
	green	red	yellow	yellow
System Off (no voltage)				
System inactive (external reset)	On		½ s T	
Smoke sensor Off (from FACP)	On		½ s T	
Idle state	On			
Pipe blockage/pipe breakage, delay time running ①	On		1 s T	
Pipe blockage / pipe breakage, fault triggered	On		On	
Fan tachometer signal missing	On		On	
Fault triggered	On		On	
Pre-signal 1	On	2 s T		
Pre-signal 2	On	1 s T		
Pre-signal 3	On	½ s T		
Alarm	On	On		
Smoke sensor filter fault	On			2 s T
Smoke sensor dusty	On			1 s T
Smoke sensor dirty	On			½ s T
Smoke sensor fault	On			On
Lamp test (press "Reset" key 10 s)	1 s T	1 s T	1 s T	1 s T



#### Notice

① No fault triggered (triggers only after delay time has expired → "Fault" continuously lit).  
T = flashing display; ½ s cycle / 1 s cycle / 2 s cycle

## 8.5.2 Displays on the AMB 33 Main Board

Besides the segment display the AMB 33 Main Board has various LEDs, with the following meaning (see also Fig. 45):

- Flashing point on the left-hand segment display = watchdog display (processor is running);
- Flashing on the segment display, point and **AL** = Autolearning is running;
- Flashing on the segment display, point and **FR** = filter replacement is running;
- On the segment display, flashing point on the left, point steady lit on the right = day/night control active (in **X01 – X03** only);
- LED 2 = watchdog display (processor not running → ASD has triggered a fault);
- LED 5 = USB interface communication, RX signal, flashing;
- LED 6 = USB interface communication, TX signal, flashing.

Other output and display possibilities on the segment display include:

- in switch position **d** > **RE** = event memory, see Sec. 7.8;
- in switch position **E** = event memory, see Sec. 8.5.3;
- in switch position **F** = firmware version, see Sec. 7.3.6;
- “UP” key pressed = set configuration (**A11 to C32, W01 to W48, X01 to X03**), see Sec. 7.6.1;
- in switch position **V** = airflow values (volume rate of flow), see Sec. 7.6.1;
- flashing **000** = invalid entry;
- flashing **U - -** = initial reset is running;
- flashing **IA1, IA2, IF1, IF2, IP1, IP2, IE1, IE2** = test trigger is activated, see Sec. 7.7.2.





## 8.5.3 Displaying and reading out the event memory

The event memory can be called up via switch position **E**. The last 99 events (event location **E01 to E99**) of the overall 430 possible events can be accessed in it. Event location **E01** always contains the last (most recent) event. The event memory as a whole can only be deleted by the manufacturer.

Events are subdivided into groups (**G00 to G99**) so they can be displayed using the 3 digits of the segment display. For each event group, up to 8 events can be displayed as a 3-digit code. The codes are added together and displayed if there are multiple pending events per event group.

### 8.5.3.1 Procedure and interpretation of the event memory display

The sequence below provides an example to illustrate how the next to last event, i.e. the second most recent event, is read out (**E02**). The result shows that smoke sensor I alarm has triggered.

Measure	Display	Procedure / remarks
(1)  Briefly press key	flashing, e.g. <b>b22</b> or other	• Displays the switch position selected at commissioning <b>A11 to C32, W01 to W48, X01 to X03</b>
(2)  Press the key again until display on <b>E</b>	in succession <b>A / b / C / d / E</b>	• Displays the switch position group <b>E</b>
(3)  Press key	<b>E01</b>	• Selects event <b>E01</b> (last, i.e. most recent)
(4)  Press key	<b>E02</b>	• Selects event <b>E02</b> (second last)
(5)  Press key	flashing after approx. 2 s, e.g. <b>G10</b>	• Displays the event group <b>G10</b> , smoke sensor events
(6) Wait	flashing after approx. 2 s, e.g. <b>001</b> ①	• Displays event codes <b>001</b> , smoke sensor alarm



### Notice

- ① **Multiple codes:** If pre-signals 1 to 3 preceded the alarm release of smoke sensor I, Item (6) will display code **057** as the result. It consists of the individual codes (added together) **001** (alarm), **008** (pre-signal 1), **016** (pre-signal 2) and **032** (pre-signal 3).

Please refer to Sec. 8.5.3.2 and 8.5.3.3 for a list of all the event groups and their events (codes).

8.5.3.2 Event groups

Event group	Purpose
G00	General events, part 1 (ASD On/Off, inactive, start initial reset, smoke sensor On/Off from FACP)
G01	General events, part 2 (time, <a href="#">Autolearning</a> , clear event memory)
G02	General events, part 3 (smoke sensor On/Off via "ASD Config")
G03	General events, part 4 (configuration change)
G04	General events, part 5 (reset events)
G10	Smoke sensor I events (alarm, dust/soiling, pre-signals, alarm 2)
G11	Smoke sensor I faults, part 1 (communication to ASD)
G12	Smoke sensor I faults, part 2 (smoke sensor events)
G13	Smoke sensor I isolate (Off/On, test results)
G14	Smoke sensor I test trigger from <b>EasyConfig</b> to FACP
G15	Smoke sensor I test trigger from „ASD Config“to FACP
G16	Smoke sensor I filter faults, filter replacement
G20	Smoke sensor II events (alarm, dust/dirt, pre-signals, alarm 2)
G21	Smoke sensor II faults, part 1 (communication to ASD)
G22	Smoke sensor II faults, part 2 (smoke sensor events)
G23	Smoke sensor II isolate (Off/On, test events)
G24	Smoke sensor II test trigger from <b>EasyConfig</b> to FACP
G25	Smoke sensor II test trigger from "ASD Config" to FACP
G26	Smoke sensor II filter faults, filter replacement
G30	Airflow monitoring sampling pipe I (pipe blockage, pipe breakage, LS-Ü parameters, airflow sensor defined/missing)
G40	Airflow monitoring sampling pipe II (pipe blockage, pipe breakage, LS-Ü parameters, airflow sensor defined/missing)
G50	Fan faults (tacho signal, regulator, current consumption)
G60	Initial reset faults (various initial reset parameters, initial reset <a href="#">time-out</a> , airflow too low)
G70	Faults RIM 1, RIM 2 faults
G71	Faults SLM / XLM / ML-SFD
G72	Faults BCB / UIM
G73	Faults MCM / SIM / LIM
G80	Faults AMB (operating system, undervoltage, clock, <a href="#">Autolearning</a> , day/night control)

8.5.3.3 Event codes within event groups

<b>G00, general events, part 1</b>	
001	Switch on ASD (supply voltage)
002	Initial reset carried out (ASD)
004	ASD switched off (inactive, via "External reset")
008	ASD switched on (via "External reset")
016	Smoke sensor I switched off from FACP (SecuriPro – SecuriFire – Integral)
032	Smoke sensor II switched off from FACP (SecuriPro – SecuriFire – Integral)
064	Smoke sensor I switched on from FACP (SecuriPro – SecuriFire – Integral)
128	Smoke sensor II switched on from FACP (SecuriPro – SecuriFire – Integral)
<b>G01, general events, part 2</b>	
001	Date and time set
002	<a href="#">Autolearning</a> start
004	<a href="#">Autolearning</a> correctly completed
008	<a href="#">Autolearning</a> interrupted
016	Event memory deleted
032	Initial reset via "ASD Config"
064	Initial reset via FACP
<b>G02, general events, part 3</b>	
001	Smoke sensor I deactivated via "ASD Config"
002	Smoke sensor II deactivated via "ASD Config"
004	Smoke sensor I activated via "ASD Config"
008	Smoke sensor II activated via "ASD Config"
032	Smoke sensor II switched off (partial planning)
128	Smoke sensor II switched on (partial planning)

→→

## Operation

Continuation:

<b>G03, general events, part 4, Configuration changes</b>													
000	X01	009	C11	018	W04	027	W13	036	W22	045	W31	054	W40
001	X02	010	C12	019	W05	028	W14	037	W23	046	W32	055	W41
002	X03	011	C21	020	W06	029	W15	038	W24	047	W33	056	W42
003	A11	012	C22	021	W07	030	W16	039	W25	048	W34	057	W43
004	A12	013	C31	022	W08	031	W17	040	W26	049	W35	058	W44
005	b11	014	C32	023	W09	032	W18	041	W27	050	W36	059	W45
006	b12	015	W01	024	W10	033	W19	042	W28	051	W37	060	W46
007	b21	016	W02	025	W11	034	W20	043	W29	052	W38	061	W47
008	b22	017	W03	026	W12	035	W21	044	W30	053	W39	062	W48
<b>G04, general events, part 5, reset events</b>													
001	Key												
002	SecuriLine												
004	"ASD Config" PC program												
008	External												
<b>G10, smoke sensor I events</b>													
001	Smoke sensor I alarm												
002	Smoke sensor I dusty												
004	Smoke sensor I dirty												
008	Pre-signal 1 smoke sensor I												
016	Pre-signal 2 smoke sensor I												
032	Pre-signal 3 smoke sensor I												
064	Alarm 2 smoke sensor I												
<b>G11, smoke sensor I faults, part 1</b>													
001	Communication ASD <> smoke sensor I												
002	Unknown smoke sensor type, smoke sensor I												
004	Response sensitivity too low, smoke sensor I												
008	Invalid parameters, smoke sensor I												
<b>G12, smoke sensor I faults, part 2</b>													
001	Smoke sensor I sampling chamber												
002	Temperature, smoke sensor I												
004	Supply voltage, smoke sensor I												
008	EEPROM access fault, smoke sensor I												
016	EEPROM invalid data, smoke sensor I												
032	Manufacture, smoke sensor I												
<b>G13, smoke sensor I isolate</b>													
001	Isolated smoke sensor I alarm												
002	Isolate smoke sensor I switched on												
004	Isolate smoke sensor I switched off (normal operation)												
008	Isolated pre-signal 1, smoke sensor I												
016	Isolated pre-signal 2, smoke sensor I												
032	Isolated pre-signal 3, smoke sensor I												
064	Isolated alarm 2, smoke sensor I												
<b>G14, smoke sensor I test trigger from EasyConfig to FACP (see G15)</b>													
<b>G15, smoke sensor I test trigger from "ASD Config" to FACP</b>													
001	Alarm test, smoke sensor I												
002	Fault test, smoke sensor I												
004	Pre-signal 1 test, smoke sensor I												
008	Pre-signal 2 test, smoke sensor I												
016	Pre-signal 3 test, smoke sensor I												
032	Test alarm 2, smoke sensor I												
<b>G16, smoke sensor I filter faults, filter replacement</b>													
001	Smoke sensor I filter fault (service life exceeded)												
016	Smoke sensor I filter replacement started												

→→

Continuation:

<b>G20, smoke sensor II events</b>	
001	Smoke sensor II alarm
002	Smoke sensor II dusty
004	Smoke sensor II dirty
008	Pre-signal 1 smoke sensor II
016	Pre-signal 2 smoke sensor II
032	Pre-signal 3 smoke sensor II
064	Alarm 2 smoke sensor II
<b>G21, smoke sensor II faults, part 1</b>	
001	Communication ASD <> smoke sensor II
002	Unknown smoke sensor type, smoke sensor II
004	Response sensitivity too low, smoke sensor II
008	Invalid parameters, smoke sensor II
<b>G22, smoke sensor II faults, part 2</b>	
001	Smoke sensor II sampling chamber
002	Temperature, smoke sensor II
004	Supply voltage, smoke sensor II
008	EEPROM access fault, smoke sensor II
016	EEPROM invalid data, smoke sensor II
032	Manufacture, smoke sensor II
<b>G23, smoke sensor II isolate</b>	
001	Isolated smoke sensor II alarm
002	Isolate smoke sensor II switched on
004	Isolate smoke sensor II switched off (normal operation)
008	Isolated pre-signal 1, smoke sensor II
016	Isolated pre-signal 2, smoke sensor II
032	Isolated pre-signal 3, smoke sensor II
064	Isolated alarm 2, smoke sensor II
<b>G24, smoke sensor II test trigger from EasyConfig to FACP (see G25)</b>	
<b>G25, smoke sensor II test trigger from "ASD Config" to FACP</b>	
001	Alarm test, smoke sensor II
002	Fault test, smoke sensor II
004	Pre-signal 1 test, smoke sensor II
008	Pre-signal 2 test, smoke sensor II
016	Pre-signal 3 test, smoke sensor II
032	Test alarm 2, smoke sensor II
<b>G26, smoke sensor II filter faults, filter replacement</b>	
001	Smoke sensor II filter fault (service life exceeded)
016	Smoke sensor II filter replacement started
<b>G30, airflow monitoring sampling pipe I</b>	
001	Pipe blockage sampling pipe I or filter element is not inserted (if DFU 911S is used)
002	Pipe breakage sampling pipe I
004	Invalid LS-Ü parameters sampling pipe I
008	Airflow sensor I defective / missing
<b>G40, airflow monitoring sampling pipe II</b>	
001	Pipe blockage sampling pipe II or filter element is not inserted (if DFU 911S is used)
002	Pipe breakage sampling pipe II
004	Invalid LS-Ü parameter, sampling pipe II
008	Airflow sensor II defective / missing
<b>G50, fan faults</b>	
001	Tacho signal missing
002	Motor regulation outside range
004	Motor current too low

→→

## Operation

Continuation:

<b>G60, initial reset faults</b>	
<b>001</b>	Initial reset value I, airflow too low
<b>002</b>	Initial reset value II, airflow too low
<b>004</b>	Initial reset <a href="#">time-out</a>
<b>008</b>	Invalid parameters for initial reset I
<b>016</b>	Invalid parameters for initial reset II
<b>032</b>	Motor speed during initial reset outside range
<b>064</b>	Initial reset value I, airflow too high
<b>128</b>	Initial reset value II, airflow too high
<b>G70, Faults RIM 1, RIM 2</b>	
<b>001</b>	RIM 1 missing or defective
<b>016</b>	RIM 2 missing or defective
<b>G71, Faults SLM / XLM / ML-SFD</b>	
<b>001</b>	SLM missing or defective
<b>004</b>	too many SLMs connected
<b>008</b>	ML-SFD missing or defective
<b>016</b>	XLM missing or defective
<b>064</b>	too many XLMs connected
<b>128</b>	too many ML-SFD connected or not permitted module combination
<b>G72, Fault BCB / UIM</b>	
<b>001</b>	BCB missing or defective
<b>032</b>	UIM missing or defective
<b>064</b>	too many UIM connected or not permitted module combination
<b>G73, Fault MCM / SIM / LIM</b>	
<b>001</b>	MCM missing or defective
<b>002</b>	MCM communication fault
<b>004</b>	too many MCMs connected
<b>008</b>	LIM missing or defective
<b>016</b>	SIM missing or defective
<b>064</b>	too many SIMs connected
<b>128</b>	too many LIM connected or not permitted module combination
<b>G80, Faults AMB</b>	
<b>001</b>	Operating system 1
<b>002</b>	Operating system 2
<b>004</b>	Undervoltage
<b>008</b>	Clock
<b>016</b>	EEPROM
<b>032</b>	Invalid Autolearning parameters
<b>064</b>	Invalid day/night control parameters

8.5.4 Operation and displays on the XLM 35, SLM 35, ML-SFD

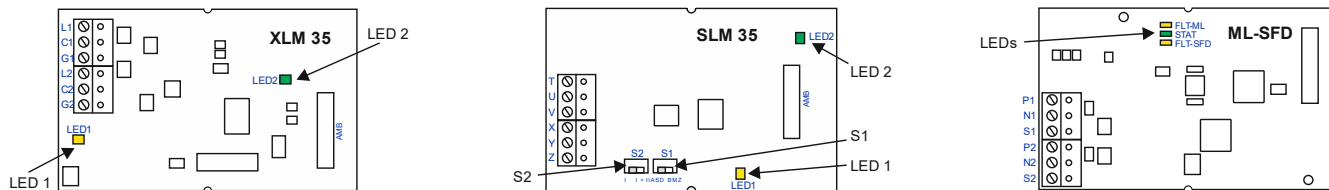

Fig. 46 Operation and display XLM 35 / SLM 35 / ML-SFD

The SLM 35 SecuriLine module has two switches (S1 and S2) with the following function (SLM 35 only):

S1 switch	ASD / FACP operation access
ASD position	Re-programming is possible only on the ASD; status query possible from FACP
BMZ position	Re-programming and status query possible from FACP and ASD
S2 switch	Number of smoke sensors in the ASD
Position I	ASD 533-1 with 1 smoke sensor, on the FACP only as one zone
Position I + II	ASD 533-2 with 2 smoke sensors, on the FACP side as V-AI / H-AI or AI zone A / AI zone B

The two LEDs on the XLM 35 and SLM 35 indicate the communication state.

LED 1 (yellow)	State XLM 35 / SLM 35 ↔ addressable loop (lit only if power supply from AMB is ok)
Not lit	No addressable loop voltage
Continuously lit (steady)	Addressable loop voltage ok, no XLM / SLM communications ↔ Line
Flashing (normal operation)	Communication XLM / SLM ↔ Line ok
LED 2 (green)	State ASD 533 ↔ XLM 35 / SLM 35
Not lit	No power supply from AMB 33
Flashing (normal operation)	Power supply from AMB 33 ok, communication XLM / SLM ↔ ASD ok

3 LEDs on the ML-SFD indicate the communication state.

DEL	Description
STAT (green)	<b>Continuously lit (normal operation):</b> <ul style="list-style-type: none"> <li>Power supply from SFD present</li> <li>Sub-controller and line-controller in operation</li> <li>Communication M-Line ↔ SFD OK</li> </ul>
	<b>Flashes in 1 s cycle:</b> <ul style="list-style-type: none"> <li>Power supply from SFD present</li> <li>Sub-controller in operation</li> <li>Communication M-Line ↔ SFD faulty (see fault LED)</li> </ul>
	<b>Not lit:</b> <ul style="list-style-type: none"> <li>no supply voltage from SFD</li> <li>ML-SFD defective</li> </ul>
FLT-SFD (yellow)	<b>Is not lit (normal operation):</b> <ul style="list-style-type: none"> <li>no fault</li> </ul>
	<b>Flashes in 1 s cycle:</b> <ul style="list-style-type: none"> <li>SFD not compatible with ML-SFD</li> </ul>
	<b>Continuously lit:</b> <ul style="list-style-type: none"> <li>Communication fault SFD ↔ sub-Ctrl (cable connection not OK)</li> </ul>
FLT-ML (yellow)	<b>Is not lit (normal operation):</b> <ul style="list-style-type: none"> <li>no fault</li> </ul>
	<b>Continuously lit:</b> <ul style="list-style-type: none"> <li>no addressable loop voltage (or no communication line controller ↔ sub-controller)</li> <li>Line controller defective</li> </ul>

## 8.5.5 Operation and displays on the MCM 35

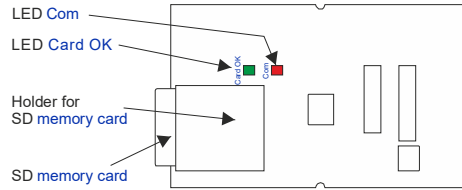

**Fig. 47 Operation and display MCM 35**

The two LEDs on the MCM 35 indicate the operating state of the SD Memory Card and the communication state (writing) from the AMB.

LED card OK (green)	SD memory card state (lit only if power supply from AMB is ok)
Not lit	Connection MCM <-> AMB not ok; SD memory card not inserted, MCM logged off
Continuously lit (steady)	Connection MCM <-> AMB ok, SD memory card inserted, MCM logged on
LED Com (red)	Communication / Write state
Not lit	No communication from AMB
Flashing (normal operation)	Communication MCM <-> AMB ok; SD memory card logging.

The MCM 35 and the SD memory card are automatically detected when the device is switched on and are monitored from then on. Data logging begins automatically after approx. 10 s.

Notices

- Inserting the SD memory card: Before using the SD memory card, make sure it is blank (file interpretation).
- Removing the SD memory card: Before removing the SD memory card from the MCM 35, the MCM 35 has to be logged off via the operation on the AMB 33 Main Board (to prevent data loss). This applies also to the subsequent removal of the MCM, e.g. because it is not being used (see Sec. 7.3.7).
- Only **industrial SD memory cards** tested and approved by the manufacturer may be used.

The SD memory card is inserted with the contact side facing toward the MCM circuit board and pushed into the holder until it snaps into place. Pressing the SD memory card again releases the locking mechanism and the SD memory card can then be removed from the holder.

### 8.5.5.1 Data logging on the MCM 35

**Smoke and airflow values:** Every second the alarm sensitivity, smoke level, soiling level and airflow values are logged and saved in **log files** (.xls file) on the SD memory card. After 28,800 entries (corresponding to 8 hours with an MCM interval of 1 s) a new **log file** is automatically generated. A total of 251 **log files** (L000.xls to L250.xls) can be generated for long-term logging. After the last **log file** the oldest one (L000.xls) is overwritten. The 251 **log files** are sufficient to cover 83 days of data logging (with MCM interval of 1 s). The **log files** can be opened in Excel and the data processed with the diagram assistant to create charts.

**Events:** All the events that occur on the ASD 533 are written to **event files** (.aev file). After 64,000 events a new **event file** is created automatically. A total of 251 **event files** (E000.aev to E250.aev) can be generated for long-term logging. After the last **event file** the oldest one (E000.aev) is overwritten. The 251 **event files** are sufficient to log over 16 million events. The **event files** can be opened with a text editor. Please refer to Sec. 8.5.3 for the interpretation of the events. There is also the possibility of importing **event files** using the “ASD Config” configuration software and displaying them as real event text.

8.5.6 Indication and control on the SIM 35

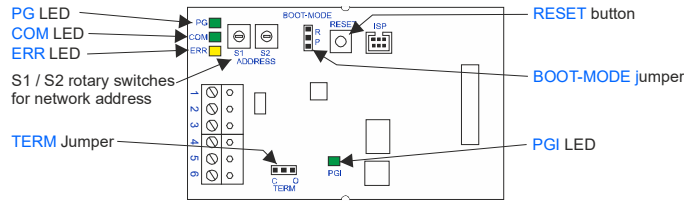

Fig. 48 SIM 35 indication and control

The functions of the rotary switches, jumpers, buttons and LEDs are shown in the following table.

The network address is set in hexadecimal code using the two rotary switches (S1 and S2). The bus termination is defined with the **TERM** jumper. This must be done on **both sides of the network** (beginning and end) (exception: when using with NCU 900 on FidesNet only on the last SIM 35). The **BOOT-MODE** jumper is used only in production. The **RESET** button initiates a HW reset on the SIM 35. The four LEDs on the SIM 35 indicate the state of the ASD network. Please refer to Sec. 11.4 for more information about the ASD network.

Rotary switch S1 / S2		Network address													
Dec	Hex	Dec	Hex	Dec	Hex	Dec	Hex	Dec	Hex						
S1	S2	S1	S2	S1	S2	S1	S2	S1	S2						
		32	2 0	64	4 0	96	6 0	128	8 0	160	A 0	192	C 0	224	E 0
1	0 1	33	2 1	65	4 1	97	6 1	129	8 1	161	A 1	193	C 1	225	E 1
2	0 2	34	2 2	66	4 2	98	6 2	130	8 2	162	A 2	194	C 2	226	E 2
3	0 3	35	2 3	67	4 3	99	6 3	131	8 3	163	A 3	195	C 3	227	E 3
4	0 4	36	2 4	68	4 4	100	6 4	132	8 4	164	A 4	196	C 4	228	E 4
5	0 5	37	2 5	69	4 5	101	6 5	133	8 5	165	A 5	197	C 5	229	E 5
6	0 6	38	2 6	70	4 6	102	6 6	134	8 6	166	A 6	198	C 6	230	E 6
7	0 7	39	2 7	71	4 7	103	6 7	135	8 7	167	A 7	199	C 7	231	E 7
8	0 8	40	2 8	72	4 8	104	6 8	136	8 8	168	A 8	200	C 8	232	E 8
9	0 9	41	2 9	73	4 9	105	6 9	137	8 9	169	A 9	201	C 9	233	E 9
10	0 A	42	2 A	74	4 A	106	6 A	138	8 A	170	A A	202	C A	234	E A
11	0 B	43	2 B	75	4 B	107	6 B	139	8 B	171	A B	203	C B	235	E B
12	0 C	44	2 C	76	4 C	108	6 C	140	8 C	172	A C	204	C C	236	E C
13	0 D	45	2 D	77	4 D	109	6 D	141	8 D	173	A D	205	C D	237	E D
14	0 E	46	2 E	78	4 E	110	6 E	142	8 E	174	A E	206	C E	238	E E
15	0 F	47	2 F	79	4 F	111	6 F	143	8 F	175	A F	207	C F	239	E F
16	1 0	48	3 0	80	5 0	112	7 0	144	9 0	176	B 0	208	D 0	240	F 0
17	1 1	49	3 1	81	5 1	113	7 1	145	9 1	177	B 1	209	D 1	241	F 1
18	1 2	50	3 2	82	5 2	114	7 2	146	9 2	178	B 2	210	D 2	242	F 2
19	1 3	51	3 3	83	5 3	115	7 3	147	9 3	179	B 3	211	D 3	243	F 3
20	1 4	52	3 4	84	5 4	116	7 4	148	9 4	180	B 4	212	D 4	244	F 4
21	1 5	53	3 5	85	5 5	117	7 5	149	9 5	181	B 5	213	D 5	245	F 5
22	1 6	54	3 6	86	5 6	118	7 6	150	9 6	182	B 6	214	D 6	246	F 6
23	1 7	55	3 7	87	5 7	119	7 7	151	9 7	183	B 7	215	D 7	247	F 7
24	1 8	56	3 8	88	5 8	120	7 8	152	9 8	184	B 8	216	D 8	248	F 8
25	1 9	57	3 9	89	5 9	121	7 9	153	9 9	185	B 9	217	D 9	249	F 9
26	1 A	58	3 A	90	5 A	122	7 A	154	9 A	186	B A	218	D A	250	F A
27	1 B	59	3 B	91	5 B	123	7 B	155	9 B	187	B B	219	D B		
28	1 C	60	3 C	92	5 C	124	7 C	156	9 C	188	B C	220	D C		
29	1 D	61	3 D	93	5 D	125	7 D	157	9 D	189	B D	221	D D		
30	1 E	62	3 E	94	5 E	126	7 E	158	9 E	190	B E	222	D E		
31	1 F	63	3 F	95	5 F	127	7 F	159	9 F	191	B F	223	D F		

Jumper <b>TERM</b>	Bus termination (position "C" = active)
Position O	SIM 535 is <b>not</b> first or last module
Position C	SIM 535 is <b>first</b> or <b>last</b> module
Jumper <b>BOOT-MODE</b>	FW upgrade (production)
Position R	Normal position
Position P	Local FW upgrade on the SIM 35
Button <b>RESET</b>	Reset SIM
Press	Triggers a HW reset of the SIM 35

LED <b>PG</b> (green)	State supply voltage
continuously lit	Supply from AMB Ok
LED <b>PGI</b> (green)	State of internal voltage supply
continuously lit	Internal voltage supply OK
LED <b>COM</b> (green)	State communication
Flashes	Communication running, "ASD Config" is active
LED <b>ERR</b> (yellow)	State SIM / fault
Flashes	Address is in invalid range
continuously lit	SIM has a fault

## 8.5.7 Indication and control on the SMM 535

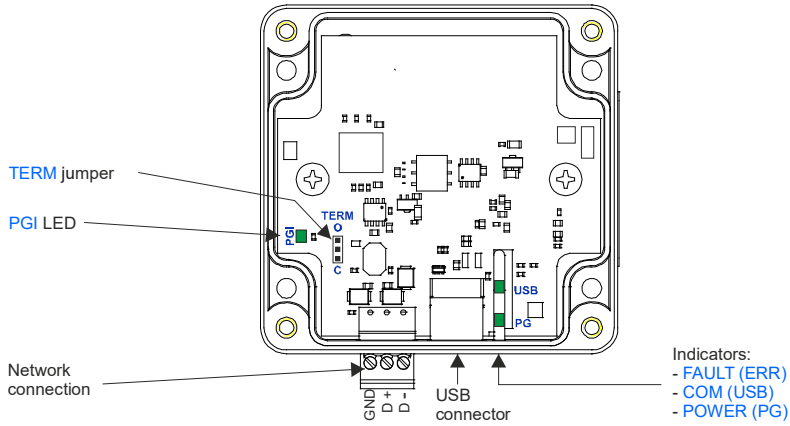

**Fig. 49 SMM 535 indication and control**

The functions of the jumpers and LEDs are shown in the following table.

The bus termination is defined with the **TERM** jumper. This must be done on **both sides of the network** (beginning and end). The three LEDs on the SMM 535 indicate the state of the ASD network. Two of these are fibre optic cables on the outside of the housing (“**FAULT**” LED is not included, optional).

<b>Jumper TERM</b>	<b>Bus termination (position “C” = active)</b>
Position <b>O</b>	SMM 535 is <b>not</b> first or last module
Position <b>C</b>	SMM 535 is <b>first</b> or <b>last</b> module
<b>POWER (PG) (green)</b>	<b>State supply voltage</b>
continuously lit	Supply from PC (USB) Ok
<b>COM (USB) (green)</b>	<b>State communication</b>
Flashes	Communication running, “ASD Config” is active
<b>LED PGI (green)</b>	<b>State of internal voltage supply</b>
continuously lit	Internal voltage supply OK

No network address has to be assigned to the SMM 535.

### 8.6 Operation from SecuriPro with SLM 35

When connecting an ASD 533 with integrated **SLM 35** from SecuriPro the ASD can also be operated via the SecuriPro user interface. The following operations can be carried out (re-programming from FACP is possible only in switch positions **X01** to **X03** and if the slide switch on the SLM 35 is in position “**BMZ**”. In the “**ASD**” position only a state query is possible, see also Sec. 7.4.3):

Command structure:	Note:
OPERATION ASD	
MANUAL	General operations
DETECTOR	Object number input (DA / DZ / DET)
ON STATUS	Switch on ASD
OFF STATUS	Switch off ASD
FACTORY SETTINGS	Restore ASD default values
POLLING OPERATION MODE	State query
SENSITIVITY SMOKE	
DETECTOR	Object number input (DA / DZ / DET)
HIGH	corresponds to 80% of “medium” ①
MEDIUM	corresponds to sensitivity for <b>A11</b> to <b>W48</b> or “ASD PipeFlow” (= 100%) ①
LOW	corresponds to 120% of “medium” ①
POLL	Status query
SENSITIVITY AIR FLOW	
DETECTOR	Object number input (DA / DZ / DET)
HIGH	corresponds to the ASD configuration ±10% ①
MEDIUM	corresponds to the ASD configuration ±20 %, for <b>A11</b> to <b>C32</b> ①
LOW	corresponds to the ASD configuration ±50% (range ±30 - ±70%) ①
POLL	Status query
DELAY AIR FLOW	
DETECTOR	Object number input (DA / DZ / DET)
HIGH	corresponds to the ASD configuration 20 min (range 11 – 60 min) ①
MEDIUM	corresponds to the ASD configuration 10 min (range 6 – 10 min) ①
LOW	corresponds to the ASD configuration 300 s, for <b>A11</b> to <b>C32</b> (range 10 s – 300 s) ①
POLL	Status query
= Normative settings according to EN 54-20	

**Notice**

① Re-programming from SecuriPro FACP may result in non-compliance with EN 54-20. Any adjustments or modifications to the ASD 533 from the SecuriPro FACP to the “low” level may only be carried out by the manufacturer or by qualified personnel trained by the manufacturer (see also Sec. 7.4.3).

### 8.7 Operation from SecuriFire / Integral with XLM 35 / ML-SFD

When connecting to the SecuriFire or Integral FACP via an **XLM 35** or **ML-SFD**, control operations and changes can be made to the ASD device configuration directly from the FACP. For this purpose the FACP user software “SecuriFire-Studio” and “Integral [Application Centre](#)” is used to start the “ASD Config” configuration software for access to the ASDs, the configuration software then being used for operating on the ASD 533.

# 9 Maintenance and service

## 9.1 General



### Notices

- Maintenance and service work on fire alarm systems are subject in part to country-specific laws and directives.
- Maintenance and service work may be performed only by persons trained and authorised by the manufacturer of the ASD 533.
- Depending on its application, the ASD 533 must be serviced at least once a year by the manufacturer or by qualified personnel authorised and trained to do so by the manufacturer. If required (e.g. significant dirt hazard), the service interval is reduced to guarantee functional reliability. If filter boxes and/or filter units are used, the service life of the filter inserts play a role in the service interval. Depending on the level of dust and dirt in the object, filter service may vary greatly. The optimum filter service life is to be determined on site on a case by case basis. When using the filter monitoring according to Sec. 2.2.18, the filter service life is set to 6 months by default, but it can be parameterised from 1 to 24 months.
- When using a DFU 911 dust filter unit, refer to Data Sheet T 140 705 for the application-specific specifications of the filter service life.

The operator is obligated to conclude a service agreement with the manufacturer or with an installer authorised by the manufacturer if the operator does not have the required service personnel trained by the manufacturer.

The statutory national directives (DIN VDE 0833-1, [VKF](#)) governing maintenance must be observed.

Servicing, maintenance or inspection work on the ASD 533 may be necessary after an event (fire, fault).

If a detector housing has to be replaced due to a defect, the new ASD 533 is to undergo the same procedure as a first-time commissioning (initial reset required). All the customer-specific configurations have to be carried out once again on the replaced ASD 533.

For maintenance work and function checks, observe the relevant information set out in Sec. 9.3 below.

If filter-boxes or dust filter units are installed in applications with a high level of soiling risk, a "simplified" maintenance can be performed on the filter-boxes or dust filter boxes as described in Sec. 9.3.1.

## 9.2 Cleaning

Clean the detector housing with a **non-aggressive** cleaning agent (e.g. soap suds or similar).

Normally only the sampling holes need to be cleaned on the sampling pipe tube network. In applications where dirt is a major issue, it may be necessary to clean inside the sampling pipe (blow out with compressed air or nitrogen). Only use a **non-aggressive** cleaning agent (e.g. soap suds or similar) for all cleaning work on the sampling pipe.



### Notice

Aggressive cleaning agents (such as solvents, pure petrol or other alcohol-based agents) must not be used for cleaning.

### 9.3 Maintenance checks and function checks



#### Notice

To avoid triggering fire incident controls, remote alerting and extinguishing areas when carrying out maintenance work, it is **essential** to block or switch off those systems beforehand.

For maintenance and function checks, carry out the following points:

1. Block or switch off the fire incident control and remote alerting on the superordinate FACP.
2. Check that the supply voltage on the FACP is set in compliance with maintenance instructions for the control panel.
3. Check the sampling pipe inlet and pipe plug of the unused inlet opening on the detector housing (ASD 533-1) for correct seating.
4. Check the air outlet for any dirt or soiling and clean if necessary.
5. If the ASD 533 is used for equipment monitoring and plug-in transitions from rigid to flexible pipe sections are in place, check that the transitions are correctly seated (no leakage).
6. Open the cover of the detector housing and secure it to the middle mounting points in the housing base. **Attention:** ribbon cable connection (see also Sec. 5.4.1 and 7.1). Carry out the following measurements:
  - Measure the operating voltage at terminals 1 (+), 2 (-) → target value = 12.3 to 13.8 VDC (in 12 VDC operation) and 21.6 to 27.6 VDC (in 24 VDC operation).
  - Read out airflow value for each sampling pipe in switch position **V** (see Sec. 7.6.1) and compare with commissioning protocol. If there is a deviation of more than half the set sensitivity (see examples ① and ②), check the sampling pipe as follows:
    - An **increase** in the value (more than 100%) tends to indicate **pipe breakage** → check the sampling pipe for leaks (junctions, fittings, etc.)
    - A **decrease** in the value (less than 100%) tends to indicate a **pipe blockage** → check the sampling pipe for pipe blockage, clean as described under **Item 9** or **Item 10**.
  - ① Set LS-Ü sensitivity = ±20% (standard); half of that = ±10%. The sampling pipe should therefore be checked if the value is below 90% or above 110%.
  - ② Set LS-Ü sensitivity = ±50% (non-compliant with EN 54-20), half of that = ±25%. The sampling pipe should therefore be checked if the value is below 75% or above 125%.
7. Deactivate the ASD (unplug terminal block 1/2 and possibly 3/4 on the AMB 33); carefully detach the ribbon cable connection to the control unit and completely remove the cover of the detector housing. After disconnecting the ribbon cable connections to the smoke sensor, carefully remove the sensor from the ASD.
8. Use a soft, dry paintbrush to clean the inside of the smoke sensor chambers and the insect protection screen. Oil-free compressed air or nitrogen can also be used for cleaning.



#### Notice

Do not use compressed air either to blow out or open the smoke sensors. Improper handling can affect the response characteristics. Only the manufacturer is authorised to clean soiled smoke sensors. The smoke sensors are monitored for dust and soiling; their state are indicated on the control unit. Replace the smoke sensors if necessary.

After cleaning the smoke sensor chambers, re-insert the smoke sensors into the ASD.



Continuation:

9. If it is necessary to clean the sampling pipe as indicated under **Item 6**, carry out the following measures (possibly also according to **Item 10**):
- Clean all the sampling holes in the entire sampling pipe tube network. Tobacco pipe cleaners can be used for this purpose.
  - If the sampling holes are not accessible, the entire sampling pipe tube network can be blown out from the detector housing using oil-free compressed air or nitrogen. This is done via the manual ball valve or from the loosened screw-junction piece (pipe connection) of the last accessory part in the direction of the sampling pipe network.



### Notice

Blowing out from inside the smoke sensor chamber (through the fan) can damage the fan and is therefore not permitted.

- If present, open the accessory parts (water retaining box, dust filter unit, detector boxes) and clean with a soft dry brush. Oil-free compressed air or nitrogen can also be used for cleaning. Replace the filter element in the dust filter unit (see also Data Sheet T 140 705). When finished, close the accessory parts again.
  - After cleaning the sampling pipe, re-connect it correctly to the ASD 533.
10. In applications where dirt is a major issue, it may be necessary to clean the air-flow sensors. As indicated in Sec. 9.4.3 detach the sensors from the holder and use a soft, dry paintbrush to clean them → **Attention: do not clean or touch the sensors surface with your fingers**. Then re-insert the air-flow sensors as indicated in Sec. 9.4.3 → make sure they are correctly seated inside the holder.
11. Restore the ribbon cable connection with the control unit and secure the cover of the detector housing to the middle mounting points of the housing base. Switch the ASD back on again and wait until the fan has reached its optimal speed (at least 5 min).
12. Check the fault triggering and alarm release and the correct alarm transmission to the FACP as described in Sec. 7.7. Log the completed tests in the commissioning protocol.
13. Read out the air-flow values  $V$  once again. If the values set out under **Item 6** are still outside the tolerance range, the airflow monitoring will have to be readjusted (initial reset as described in Sec. 7.3.5).



### Notices

- A new initial reset is not usually necessary after cleaning work on the sampling holes (cleaning restores the commissioning state). If an initial reset is necessary nonetheless after the work set out under **Item 13**, it may **only** be carried out once it has been ensured that all possible measures for cleaning the sampling pipe have been carried out (incl. a new filter element).
- If an initial reset is carried out with blocked sampling holes, there is the danger that insufficient air samples or no air samples will be aspirated and hence the ASD 533 can no longer trigger an alarm.

14. If maintenance or repair work was carried out on the ASD 533 (including the sampling pipe) as a result of servicing check, a new initial reset may be necessary (see Sec. 7.3.5).
15. All the measurements and tests carried out are to be entered and signed for in the commissioning protocol. The completed commissioning protocol is to be stored with the ASD. If required, a copy can be made and stored in the system dossier.
16. After completion of the servicing check, close the detector housing once again.

### 9.3.1 Filter replacement on dust filter units

If a "Filter fault (service life exceeded)" fault trigger occurs when filter monitoring is activated and after expiry of the configured filter service life, the filter element in a dust filter unit must be replaced. When the expired filter service life (read out via *EasyConfig* switch position **d > RE**) is periodically checked, the replacement can take place before the fault is triggered. See also Sec. 7.8.

To replace the filter element, the "Filter replacement" function must be activated on the ASD (via the "Reset" key, *EasyConfig* or "ASD Config"). When filter replacement is activated, the aspirating smoke detector is set to the "Isolate" state. This insures that during the replacement work falling dust particles from the filter element do not cause a false alarm. After the filter has been replaced, the "Filter replacement" procedure is completed by pressing the "Reset" key on the ASD. This cancels the "Isolate" state and resets the fault on the ASD. The "Filter service life" monitoring is restarted at 0 (see Sec. 7.8).

### 9.4 Replacing units



#### Notice

Defective units such as the AMB 33, smoke sensors, airflow sensors and fan may only be replaced in the de-energised state (with terminal block 1/2 and possibly 3/4 unplugged from the AMB 33).

#### 9.4.1 Replacing the smoke sensors

The replacement of a smoke sensor is necessary if it is defective or if there is a dirty message. To replace, proceed according to Sec. 6.3.

#### 9.4.2 Replacing the aspirating fan unit

The AMB 33 main board has to be removed before the AFU 35 aspirating fan unit can be replaced. To do so, carefully unplug all the internal cable connections. Remove the fan's three connection wires from the terminals. The plug-in terminals 1 to 26 do not necessarily have to be unplugged. After removing the fastening screws on the AMB 33 using a **Torx T10 screwdriver**, the AMB 33 can be lifted up toward the cable infeeds and the fastening screws on the aspirating fan unit are then accessible. To dismantle the aspirating fan unit, remove the five screws **A** using a **Torx T15 screwdriver** (see Fig. 50).



#### Notices

- Do not remove screws **B** on the aspirating fan unit.
- When connecting the new aspirating fan unit, take note of the wire colour coding (see Fig. 50).
- After replacing the aspirating fan unit, it is imperative to carry out a new initial reset (see Sec. 7.3.5).

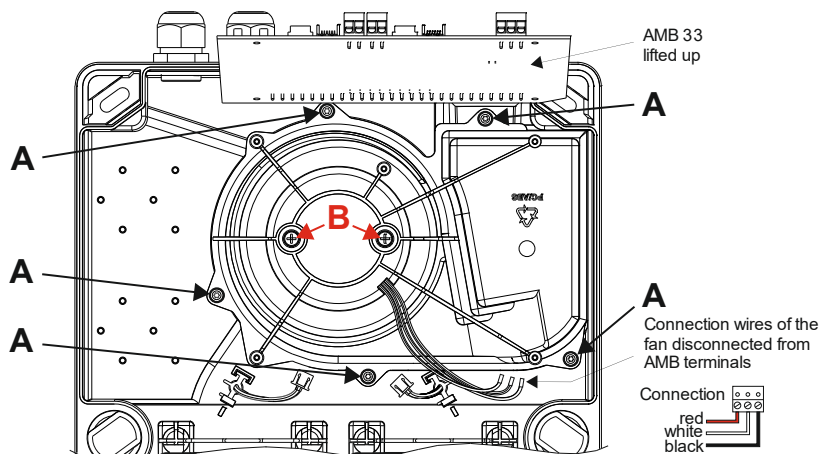

Fig. 50 Removing the aspirating fan unit

### 9.4.3 Replacing the airflow sensor



#### Notices

- When removing and mounting the airflow sensor, make sure that the sensor element is not damaged (i.e. does not break). Do not pull on the connection wires.
- After replacing an airflow sensor (new sensor), it is imperative to carry out a new initial reset (see Sec. 7.3.5).

Remove connector **A** of the airflow sensor on the AMB 33. To remove an airflow sensor, gently press lock tab **B** towards the smoke sensor chamber. The airflow sensor can then be carefully pulled out of its holder by gripping tab **C** with thumb and index finger → **Attention: do not pull on the connection wires of the airflow sensor.** To install the new airflow sensor proceed in the reverse sequence. It is important to note the installation position (anti-twist safeguard) of the airflow sensor and that it is correctly seated in its holder. To do so, press the airflow sensor by its grip tabs **C** towards the housing base until the lock tab snaps over the airflow sensor → **Attention: do not press on the connection wires of the airflow sensor.**

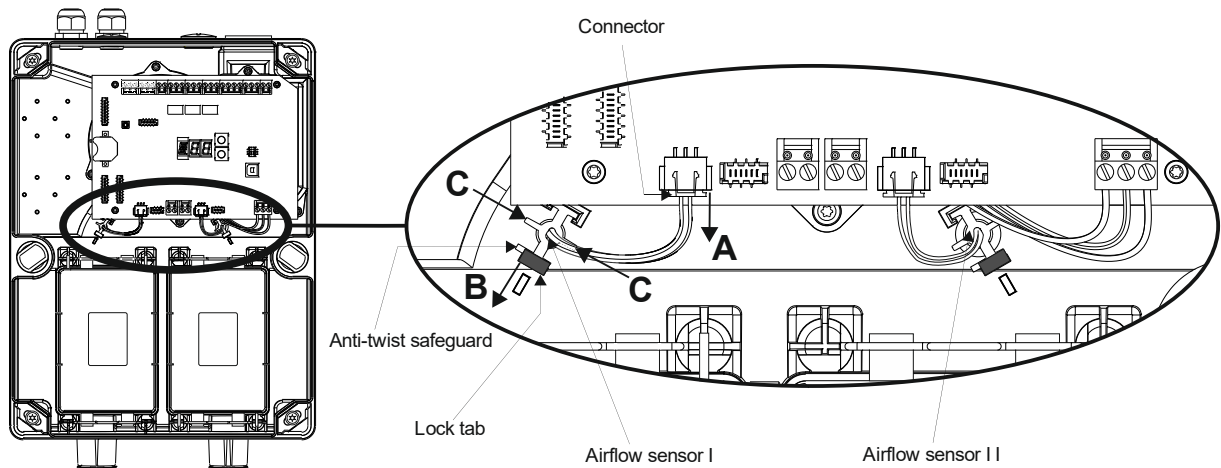

Fig. 51 Removing the airflow sensors

### 9.4.4 Replacing the AMB 33 Main Board

To replace the AMB 33 Main Board, unplug all the plug-in terminals with installation wires. Likewise, all internal cable connections (ribbon cable connectors) must also carefully be unplugged. Once the 4 fastening screws of the AMB 33 have been removed using a **Torx T10 screwdriver**, the AMB 33 can be replaced. To install the new AMB 33, proceed in the reverse sequence.



#### Notices

- When connecting the new AMB 33, take note of the correct assignment of the terminals and ribbon cable connectors (see Fig. 5).
- After replacing the AMB 33 it is imperative to carry out a new initial reset (see Sec. 7.3.5). Likewise, all customer-specific configurations and project-specific settings from the "ASD PipeFlow" configuration software must be carried out once again. To do so, proceed according to Sec. 7.3.1 and 7.3.2.

### 9.4.5 Replacing printed circuit boards BCB 35

To replace the printed circuit boards BCB 35 of the display panel, carefully unplug the ribbon cable connection on the BCB 35. Once the 4 fastening screws of the BCB 35 have been removed using a **Torx T10 screwdriver**, proceed with the replacement. Installation is in the reverse order.

### 9.5 Disposal

The ASD 533 aspirating smoke detector and its packaging consist of recyclable material that can be disposed of as described in Sec. 9.5.1.

#### 9.5.1 Materials used



#### Recycling

All the raw materials and other materials used in the ASD 533 and all the technologies used in manufacturing are ecologically and environmentally friendly in compliance with ISO 14000.



All waste resulting from assembly (packaging and plastic parts) can be recycled and should be disposed of accordingly.

Devices, sampling pipes or parts thereof that are no longer used should be disposed of in an environmentally-friendly manner.

The manufacturer of the ASD 533 undertakes to take back any devices and sampling pipes that are defective or no longer used, for eco-friendly disposal. For this purpose the manufacturer has implemented a monitored and approved disposal system. This service is available worldwide at cost price.

#### Materials used in the ASD 533:

Detector housing	PC / ABS
Smoke sensor SSD 533	Lexan (PC)
Fan housing / fan wheel	PBTP / PA6
Fan electric motor	PU / Cu / barium ferrite powder
Circuit boards, general	Epoxy resin hard paper
Soldering process	Environmentally-friendly manufacturing compliant with RoHS
Foil on control unit	PE
Sampling tubes	ABS / PA
Fittings	ABS / PA
Pipe clamp	PA
ABS adhesives	ABS / solvent MEK (methyl, ethyl, ketone)



#### Notice with PVC plastics

Because PVC plastics when burned produce toxic, corrosive and environmentally damaging combustion products, the use of PVC is not permitted in many applications. The relevant construction regulations must be observed.

#### Ecology:

PVC plastics cannot be manufactured and disposed of without environmental impact. The recycling of PVC is possible only up to a limited degree. Please refer to the danger notice above.

Sampling tubes	PVC, see danger notice above
Fittings	PVC, see danger notice above
PVC adhesives	PVC / solvent tetrahydrofuran, cyclohexanone

## 10 Faults

### 10.1 General

When troubleshooting, do not make any on-site modifications to the printed circuit boards. This applies in particular to replacing or changing soldered components. Defective printed circuit boards and units are to be completely replaced by the corresponding spare part according to Sec. 12.1. No repairs of defective printed circuit boards and units will be undertaken by the manufacturer. It is nevertheless possible to return complete ASD devices to be checked if there is a complaint or if a guarantee is the issue.



#### Notice

Printed circuit boards are to be replaced or changed only by trained and qualified personnel. Handling must adhere to the measures for safeguarding against electrostatic charges.

### 10.2 Warranty claims

Failure to observe the aforementioned rules of conduct will invalidate any warranty claims and manufacturer's liability for the ASD 533.



#### Notices

- Repairs to the device or parts thereof are to be carried out only by personnel trained by the manufacturer. Non-observance of this regulation will invalidate any warranty claims and the manufacturer's liability for the ASD 533.
- All repairs and troubleshooting measures are to be documented.
- The ASD 533 must undergo a function check following a repair or troubleshooting measure.

## 10.3 Finding and rectifying faults

### 10.3.1 Fault states

In the event of a fault the fault profile can be localised using the event memory and the corresponding event code display, which is obtained using the segment display on the AMB 33 (switch position **E**). The table below lists the event codes for possible fault states and how to rectify them. A list of all the event codes is provided in Sec. 8.5.3.3.



#### Notice

**Multiple codes:** If there are multiple events for any given event group, the display readings are added together. Example: Display **012** = event code **004** and **008**.

<b>G10 or G20, smoke sensor I / II events</b>			
<b>Code</b>	<b>Meaning:</b>	<b>Check:</b>	<b>Possible causes and remedy:</b>
<b>002</b>	Dust	Check smoke sensor chamber, sampling pipe and dust filter unit for dust deposits	<ul style="list-style-type: none"> <li>• Clean interior of smoke sensor chamber and insect protection screen</li> <li>• Check and clean sampling pipe and, if necessary, dust filter unit</li> <li>• Replace smoke sensor</li> </ul>
<b>004</b>	Dirt	Check smoke sensor chamber, sampling pipe and dust filter unit for dirt deposits	<ul style="list-style-type: none"> <li>• Clean interior of smoke sensor chamber and insect protection screen</li> <li>• Check and clean sampling pipe and, if necessary, dust filter unit</li> <li>• Replace smoke sensor</li> </ul>
<b>G11 or G21, smoke sensor I / II faults, part 1</b>			
<b>Code</b>	<b>Meaning</b>	<b>Check:</b>	<b>Possible causes and remedy:</b>
<b>001</b>	Communication ASD <-> smoke sensor	Ribbon cable connection AMB, smoke sensor	<ul style="list-style-type: none"> <li>• Ribbon cable not correctly attached or defective → check, replace</li> <li>• Smoke sensor defective → replace</li> <li>• AMB defective → replace</li> </ul>
<b>002</b>	Unknown smoke sensor type (manufacturing fault)	Smoke sensor	<ul style="list-style-type: none"> <li>• Replace smoke sensor</li> </ul>
<b>008</b>	Invalid parameters (manufacturing fault)	Smoke sensor	<ul style="list-style-type: none"> <li>• Replace smoke sensor</li> </ul>
<b>G12 or G22, smoke sensor I / II faults, part 2</b>			
<b>Code</b>	<b>Meaning</b>	<b>Check:</b>	<b>Possible causes and remedy:</b>
<b>001</b>	Measuring chamber	Smoke sensor	<ul style="list-style-type: none"> <li>• Smoke sensor defective → replace</li> </ul>
<b>002</b>	Temperature	ASD ambient temperature Smoke sensor	<ul style="list-style-type: none"> <li>• Adhere to ambient temperature specifications</li> <li>• Smoke sensor defective → replace</li> </ul>
<b>004</b>	Supply voltage	Check ASD operating voltage AMB, smoke sensor	<ul style="list-style-type: none"> <li>• Set operating voltage correctly</li> <li>• AMB defective → replace</li> <li>• Smoke sensor defective → replace</li> </ul>
<b>008</b>	EEPROM access error	Smoke sensor	<ul style="list-style-type: none"> <li>• Smoke sensor defective → replace</li> </ul>
<b>016</b>	EEPROM invalid data	Smoke sensor	<ul style="list-style-type: none"> <li>• Smoke sensor defective → replace</li> </ul>
<b>032</b>	Manufacturing	Smoke sensor	<ul style="list-style-type: none"> <li>• Smoke sensor defective → replace</li> </ul>
<b>G16 or G26, smoke sensor I / II filter faults</b>			
<b>Code</b>	<b>Meaning</b>	<b>Check:</b>	<b>Possible causes and remedy:</b>
<b>001</b>	Filter fault (service life exceeded)	① Check of whether the filter service life is correctly configured for the object-specific ambient dust and soiling load.	<ul style="list-style-type: none"> <li>• Insert filter element</li> <li>• If ① applies → increase filter service life</li> </ul>



Continuation:

<b>G30 or G40, airflow monitoring sampling pipe I / II</b>			
<b>Code</b>	<b>Meaning</b>	<b>Check:</b>	<b>Possible causes and remedy:</b>
<b>001</b>	Pipe blockage sampling pipe or filter element is not inserted (if DFU 911S is used)	Sampling pipe, air outlet on the ASD, dust filter unit, filter element soiled (or "not inserted" in DFU 911S), LS sensor	<ul style="list-style-type: none"> <li>• Check sampling pipe for pipe blockage (sampling holes, air outlet)</li> <li>• Check and clean dust filter unit</li> <li>• Filter element is not inserted (if DFU 911S is used)</li> <li>• Check and clean LS sensor</li> </ul>
<b>002</b>	Pipe breakage sampling pipe	Sampling pipe, LS sensor	<ul style="list-style-type: none"> <li>• Check sampling pipe for pipe breakage</li> <li>• Check maintenance hole</li> <li>• Sampling pipe not correctly fitted</li> <li>• Junctions open (fittings, flexible transitions)</li> <li>• Check and clean LS sensor</li> </ul>
<b>004</b>	Invalid LS-Ü parameters	Sampling pipe	<ul style="list-style-type: none"> <li>• Outside of range (working point)</li> <li>• Check and clean LS sensor</li> <li>• LS sensor defective → replace</li> </ul>
<b>008</b>	Airflow sensor defective / missing	Airflow sensor Connection line	<ul style="list-style-type: none"> <li>• Not fitted, not mounted</li> <li>• Connection line defective</li> <li>• LS sensor defective → replace</li> </ul>
<b>G50, faults fan</b>			
<b>Code</b>	<b>Meaning</b>	<b>Check:</b>	<b>Possible causes and remedy:</b>
<b>001</b>	Tacho signal missing	Check fan terminals (white wire)	<ul style="list-style-type: none"> <li>• Poor connection</li> <li>• Fan defective</li> <li>• AMB defective → replace</li> </ul>
<b>002</b>	Motor regulation outside range	Check ASD operating voltage, Check fan connection	<ul style="list-style-type: none"> <li>• Set operating voltage correctly</li> <li>• Fan defective → replace</li> <li>• AMB defective → replace</li> </ul>
<b>004</b>	Motor current too low	Fan unit, fan connection	<ul style="list-style-type: none"> <li>• Fan mechanically blocked</li> <li>• Fan defective → replace</li> <li>• AMB defective → replace</li> </ul>
<b>G60, faults initial reset</b>			
<b>Code</b>	<b>Meaning</b>	<b>Check:</b>	<b>Possible causes and remedy:</b>
<b>001</b>	Initial reset value I, airflow too low	Sampling pipe I	<ul style="list-style-type: none"> <li>• Consequence of <b>G30 / 004</b></li> </ul>
<b>002</b>	Initial reset value II, airflow too low	Sampling pipe II	<ul style="list-style-type: none"> <li>• Consequence of <b>G40 / 004</b></li> </ul>
<b>004</b>	Initial reset <b>time-out</b>	Motor run-in time	<ul style="list-style-type: none"> <li>• Failure to observe waiting time before initial reset</li> <li>• Carry out new initial reset</li> </ul>
<b>008</b>	Invalid parameters for initial reset I	Sampling pipe I specifications	<ul style="list-style-type: none"> <li>• Observe sampling pipe I specifications</li> <li>• Initial reset was interrupted (by "ASD Off") → new initial reset</li> </ul>
<b>016</b>	Invalid parameters for initial reset II	Sampling pipe II specifications	<ul style="list-style-type: none"> <li>• Observe sampling pipe II specifications</li> <li>• Initial reset was interrupted (by "ASD Off") → new initial reset</li> </ul>
<b>032</b>	Motor speed during initial reset outside range	Sampling pipe I and/or II specifications	<ul style="list-style-type: none"> <li>• Consequence of <b>G60 / 008</b> and/or <b>G60 / 016</b></li> </ul>
<b>064</b>	Initial reset value I, airflow too high	Sampling pipe I	<ul style="list-style-type: none"> <li>• Consequence of <b>G30 / 004</b></li> </ul>
<b>128</b>	Initial reset value II, airflow too high	Sampling pipe II	<ul style="list-style-type: none"> <li>• Consequence of <b>G40 / 004</b></li> </ul>

→→

## Faults

Continuation:

<b>G70, Faults RIM 1, RIM 2</b>			
<b>Code</b>	<b>Meaning</b>	<b>Check:</b>	<b>Possible causes and remedy:</b>
<b>001</b>	RIM 1 missing or defective	Ribbon cable connection Module	<ul style="list-style-type: none"> <li>• Ribbon cable not correctly attached or defective → check, replace</li> <li>• Module was removed without logging off</li> <li>• Module defective → replace</li> </ul>
<b>016</b>	RIM 2 missing or defective		
<b>G71, SLM / XLM / ML-SFD faults</b>			
<b>Code</b>	<b>Meaning</b>	<b>Check:</b>	<b>Possible causes and remedy:</b>
<b>001</b>	SLM missing or defective	Flat cable connection Module	<ul style="list-style-type: none"> <li>• Flat cable not correctly attached or defective → check, replace</li> <li>• Module was removed without logging off</li> <li>• Module defective → replace</li> </ul>
<b>004</b>	too many SLMs connected	Number of SLMs	<ul style="list-style-type: none"> <li>• only 1 SLM permitted!</li> </ul>
<b>008</b>	ML-SFD missing or defective	Flat cable connection Module	<ul style="list-style-type: none"> <li>• Flat cable not correctly attached or defective → check, replace</li> <li>• Module was removed without logging off</li> <li>• Module defective → replace</li> </ul>
<b>016</b>	XLM missing or defective	Flat cable connection Module	<ul style="list-style-type: none"> <li>• Flat cable not correctly attached or defective → check, replace</li> <li>• Module was removed without logging off</li> <li>• Module defective → replace</li> </ul>
<b>064</b>	too many XLMs connected	Number of XLMs	<ul style="list-style-type: none"> <li>• only 1 XLM permitted!</li> </ul>
<b>128</b>	too many ML-SFD connected or not permitted module combination	Number of ML-SFDs Module combination	<ul style="list-style-type: none"> <li>• only 1 ML-SFD permitted!</li> <li>• no combination with SLM, XLM, UIM possible</li> </ul>
<b>G72, BCB / UIM faults</b>			
<b>Code</b>	<b>Meaning</b>	<b>Check:</b>	<b>Possible causes and remedy:</b>
<b>001</b>	BCB missing or defective	Ribbon cable connection BCB	<ul style="list-style-type: none"> <li>• Ribbon cable not correctly attached or defective → check, replace</li> <li>• BCB defective → replace</li> </ul>
<b>032</b>	UIM missing or defective	Flat cable connection Module	<ul style="list-style-type: none"> <li>• Flat cable not correctly attached or defective → check, replace</li> <li>• Module was removed without logging off</li> <li>• Module defective → replace</li> </ul>
<b>064</b>	too many UIM connected or not permitted module combination	Number of UIMs Module combination	<ul style="list-style-type: none"> <li>• only 1 UIM permitted!</li> <li>• no combination with SLM, XLM, ML-SFD, LIM possible</li> </ul>
<b>G73, faults MCM / SIM / LIM</b>			
<b>Code</b>	<b>Meaning</b>	<b>Check:</b>	<b>Possible causes and remedy:</b>
<b>001</b>	MCM missing or defective	SD memory card Module Flat cable connection	<ul style="list-style-type: none"> <li>• SD memory card missing or not snapped in</li> <li>• Flat cable not correctly attached or defective → check, replace</li> <li>• SD memory card or module was removed without logging off</li> <li>• Module defective → replace</li> </ul>
<b>002</b>	MCM communication fault	Flat cable connection Module SD memory card	<ul style="list-style-type: none"> <li>• Flat cable not correctly attached or defective → check, replace</li> <li>• Module defective → replace</li> <li>• SD memory card defective → replace</li> </ul>
<b>004</b>	too many MCMs connected	Number of MCMs	<ul style="list-style-type: none"> <li>• Only 1 MCM permitted!</li> </ul>
<b>008</b>	LIM missing or defective	Flat cable connection Module	<ul style="list-style-type: none"> <li>• Flat cable not correctly attached or defective → check, replace</li> <li>• Module was removed without logging off</li> <li>• Module defective → replace</li> </ul>
<b>016</b>	SIM missing or defective	Flat cable connection Module	<ul style="list-style-type: none"> <li>• Flat cable not correctly attached or defective → check, replace</li> <li>• Module was removed without logging off</li> <li>• Module defective → replace</li> </ul>
<b>064</b>	too many SIMs connected	Number of SIMs	<ul style="list-style-type: none"> <li>• only 1 SIM permitted!</li> </ul>
<b>128</b>	too many LIM connected or not permitted module combination	Number of LIMs Module combination	<ul style="list-style-type: none"> <li>• only 1 LIM permitted!</li> <li>• no combination with UIM possible</li> </ul>

→→

Continuation:

<b>G80, AMB faults</b>			
<b>Code</b>	<b>Meaning</b>	<b>Check:</b>	<b>Possible causes and remedy:</b>
<b>001</b>	Operating system 1	AMB	<ul style="list-style-type: none"> <li>• AMB defective → replace</li> </ul>
<b>002</b>	Operating system 2	AMB	<ul style="list-style-type: none"> <li>• AMB defective → replace</li> </ul>
<b>004</b>	Undervoltage	Operating voltage < 10.4 VDC Conductor cross-section	<ul style="list-style-type: none"> <li>• Conductor cross-section too small → must be increased</li> <li>• Voltage of power supply not ok → check and correct if needed</li> </ul>
<b>008</b>	Clock	Lithium battery Clock setting	<ul style="list-style-type: none"> <li>• Isolation strip still fitted to lithium battery → remove</li> <li>• Clock is not set</li> <li>• Lithium battery defective → replace</li> </ul>
<b>016</b>	EEPROM	AMB	<ul style="list-style-type: none"> <li>• Execute HW reset</li> <li>• AMB defective → replace</li> </ul>
<b>032</b>	Invalid Autolearning parameters	Autolearning configuration AMB	<ul style="list-style-type: none"> <li>• Re-configure Autolearning ("ASD Config")</li> <li>• AMB defective → replace</li> </ul>
<b>064</b>	Invalid day/night control parameters	Day/night control configuration AMB	<ul style="list-style-type: none"> <li>• Re-configure day/night control ("ASD Config")</li> <li>• AMB defective → replace</li> </ul>

# 11 Options

## 11.1 Sampling pipe

If the sampling pipe is being used in extremely corrosive environments, provide for sufficiently resistant tube materials. Please contact the manufacturer of the ASD 533 for the material specifications.



### Notices

- Tube materials other than those listed in Sec. 5.3 may be used only after consulting with the manufacturer of the ASD 533 and with his written consent.
- Only use tubes (material, supplier, dimensions) which have been tested and approved by the manufacturer of the ASD 533 (see also Sec. 5.3).

## 11.2 Use under extreme conditions

Applications with extremely high levels of dust and/or dirt, extreme temperature ranges and/or atmospheric humidity outside the specified limit values require the use of accessory parts as instructed by the manufacturer, e.g.:

- Dust filter unit;
- Dirt trap box;
- Dust retaining box;
- Water retaining box;
- Manual ball valve for sporadic cleaning of the sampling pipe using compressed air;
- Automatic blow-out device;
- Insulation of the sampling pipe;
- Use of cooling sections in the sampling pipe;



### Notices

- Operation and application under extreme conditions may be implemented only after consulting with the manufacturer and under his supervision.
- The use of the aforementioned accessory parts is subject to a sampling pipe calculation using "ASD PipeFlow" (Exceptions, see Sec. 4.3.2).
- The initial reset during commissioning must be carried out with the accessory parts required for operation under extreme conditions.
- If an additional unit is retrofitted to an ASD 533 already installed, a new initial reset must be carried out.

## 11.3 Use of detector boxes

Additional detector boxes (e.g. REK 511) may have to be used in the sampling pipe to create detection areas. The applicable country-specific guidelines must be observed (e.g. DIN VDE 0833-2 in Germany, VKF in Switzerland). For more information on the REK 511 detector box, please refer to the separate data sheet (T 135 422).



### Notices

- The REK 511 detector box cannot be operated from the ASD 533. The REK 511 detector box has to be connected directly from the FACP using an appropriate addressing module.
- When using detector boxes, it may be necessary to carry out a sampling pipe calculation using "ASD PipeFlow" (see Sec. 4.3.2).

## 11.4 ASD network

The ASD network can be implemented in different ways:

- on “ASD Config” via RS-485 interface from SIM 35 / SMM 535, max. 250 participants, Sec. 11.4.1;
- on FidesNet via RS-485 interface from SIM 35 / NCU 900, max. 100 participants, Sec. 11.4.2.

A combination of ASD 533, ASD 535 and ASD 532 is possible in an ASD network.



### Notices

- The normative alarm transmission of the ASD 533 to the higher level point does not use the ASD network. The “Alarm” / “Fault” relays in the ASD, or the SecuriPro- / SecuriFire- / Integral addressable loop are to be used from the XLM 35, ML-SFD or SLM 35.
- The ASD network cannot be combined with the ADW network.

### 11.4.1 ASD networking to “ASD Config” via RS-485 interface from SIM 35 / SMM 535

Several ASDs can be networked with each other using the SIM 35 additional module. An ASD network can have up to 250 participants. The master module in the ASD network is the SMM 535, by means of which a PC is connected. Using the “ASD Config” configuration software, all ASD 533 units present in the network can be visualised and operated from the PC. The SIM 35 provides galvanic separation between the RS-485 interface and the AMB 33 (ASD 533).

Each SIM 35 and ASD 533 is assigned its own address. They are assigned based on the wiring topology in **ascending order** (see also Fig. 52).

The SIM 35 has two rotary switches (S1 and S2) for setting the network address (see Sec. 8.5.6).

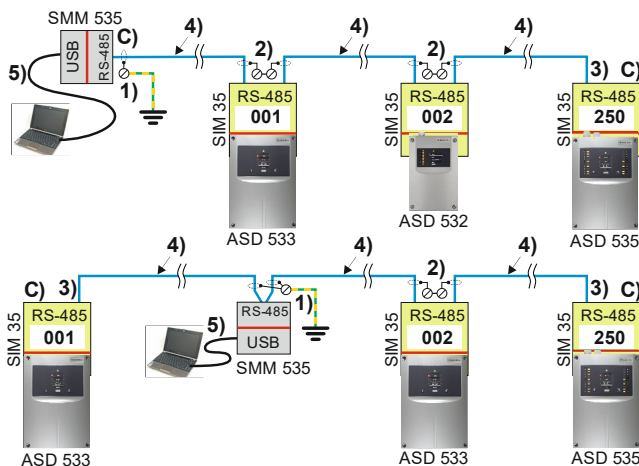

Fig. 52 Design of an RS-485 ASD network

- 1) Screen with equipotential bonding connected, always only on the SMM 535, do not connect on the last SIM 35; 3).
  - 2) Screen connected by means of a lustre terminal.
  - 3) If SMM 535 is in the network, do not connect the screen on the first and last SIM 35 (beginning and end).
  - 4) Network cable: 4-core, twisted / screened (only 3 wires are used, total length max. 1.000 m).
  - 5) USB cable; max. 3 m in length.
- C) There must be bus termination on both sides of the network (beginning and end); jumper “**TERM**”, position “**C**”.

## 11.4.2 ASD networking on FidesNet

When networking to the FidesNet, the SIM 35 additional module is also used to provide galvanic isolation. The NCU 900 is the RS-485 master module in the FidesNet. An ASD network on the FidesNet can have up to 100 participants. ASD 532s in the FidesNet can also be implemented directly from the ASD's Ethernet interface. Further information about the FidesNet can be found in Technical Description T 140 741.

The connection of the serial interface is via the SIM 35 as shown in **Fig. 53** below. The NCU 900 is at the beginning of the installation.

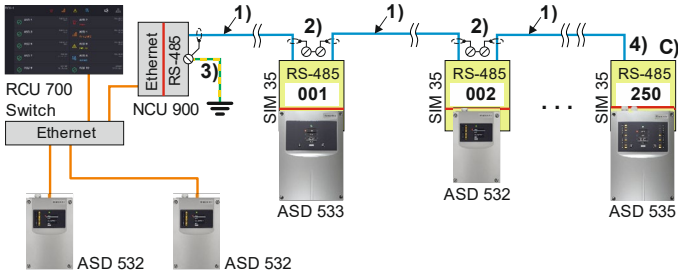

**Fig. 53 Design of a FidesNet network**

The SIM 35 has two rotary switches (S1 and S2) for setting the network address (see Sec. 8.5.6).

- 1) Network cable: 4-wire, twisted pair / screened.
- 2) Screen connected with a lustre terminal (not included in delivery).
- 3) Screen connected to equipotential bonding via NCU housing, always only on the NCU 900.
- 4) Do not connect screen on last SIM 35 in the installation.
- C) The bus termination must take place on the last SIM 35 (jumper "TERM", position "C").

## 12 Article numbers and spare parts

### 12.1 Detector housings and accessories

Designation	Article no.
Aspirating smoke detector ASD 533-1	11-2000001-01-XX
Aspirating smoke detector ASD 533-2	11-2000059-01-XX
Replacement smoke sensor SSD 533	11-2200006-01-XX
SecuriLine eXtended module XLM 35 incl. mounting set	11-2200003-01-XX
M-Line module ML-SFD including mounting set	11-2200015-01-XX
SecuriLine module SLM 35 incl. mounting set	4000286.0101
Relay Interface Module RIM 35 incl. mounting set	11-2200031-01-XX
Memory Card Module MCM 35 with SD memory card (industrial version) incl. mounting set	11-2200057-01-XX
SD memory card (industrial version)	11-4000007-01-XX
Serial Interface Module SIM 35, including mounting set	11-2200000-01-XX
Serial Master Module SMM 535	11-2200001-01-XX
USB cable, 4.5 m	4301248
Printed circuit board AMB 33-1 main board	11-2200004-01-XX
Printed circuit board AMB 33-2 main board	11-2200065-01-XX
Printed circuit board without smoke level indicator BCB 35	11-2200053-01-XX
Aspirating fan unit AFU 35, complete	11-2200052-01-XX
Airflow sensor AFS 35	11-2200051-01-XX
Insect protection screen IPS 35 (set of 2)	11-2300012-01-XX
Lithium battery	11-4000002-01-XX
Cable screw union M20 (set of 10)	11-4000003-01-XX
Cable screw union M25 (set of 10)	11-4000004-01-XX
Adapters for US cable screw unions AD US M-Inch	11-2300029-01-XX
Universal module support UMS 35	11-2200061-01-XX

### 12.2 Sampling pipe and accessories

The article numbers of all the available parts for the sampling pipe (tubes, fittings, etc.) are listed in a separate document (T 131 194).

## 13 Technical data

Type	ASD 533			
Supply voltage range	10.5 to 30 (UL/FM = 12.4 to 27)			VDC
Maximum power consumption, measured at →	in 12 VDC operation	in 24 VDC operation	Typical	
	10.5 VDC ①	18 VDC ①	24 VDC	
ASD 533-1 (at fan speed Level I)	Quiescent/fault	approx. 265	approx. 160	approx. 130 mA
	Alarm	approx. 340	approx. 210	approx. 160 mA
ASD 533-2 (at fan speed Level II)	Quiescent/fault	approx. 370	approx. 220	approx. 170 mA
	Alarm	approx. 450	approx. 270	approx. 205 mA
additionally with 1 RIM 35 unit (all relays triggered)		approx. 15	approx. 10	approx. 7 mA
additionally with 2 RIM 35 units (all relays triggered)		approx. 30	approx. 20	approx. 14 mA
additionally with XLM 35 / ML-SFD / SLM 35		approx. 20	approx. 10	approx. 5 mA
additionally with MCM 35		approx. 25	approx. 15	approx. 10 mA
additionally with SIM 35		approx. 20	approx. 10	approx. 5 mA
SMM 535 (not from ASD but rather from PC via USB connection)				max. 100 mA
Switch-on current peak ② (caused by EMC protection elements on the ASD supply input)				approx. 5 A, for max. 1 ms
Sampling pipe length				see Sec. 4.2.1
Sampling pipe diam., typical (inner/outer)				Ø 20 / 25 mm
Max. number of sampling holes				see Sec. 4.2.1
Sampling hole diameter				Ø 2 / 2.5 / 3 / 3.5 / 4 / 4.5 / 5 / 5.5 / 6 / 6.5 / 7 mm
Response range (Sensitivity: Alarm 0.02 %/m – 10 %/m, pre-signals 0.002 %/m – 9 %/m)				EN 54-20, class A, B, C
Protection type acc. to IEC 60529 / EN 60529				54 IP
Ambient conditions acc. to IEC 60721-3-3 / EN 60721-3-3				3K5 / 3Z1 class
Extended ambient conditions:				
• Detector housing temperature range				-20 – +60 (UL max. +40) °C
• Sampling pipe temperature range				-20 – +60 ③ °C
• max. permissible temperature fluctuation in detector housing and sampling pipe operation				20 ③ °C
• max. permissible storage temperature for detector housing (without condensation)				-20 – +70 °C
• Ambient pressure difference between detector housing and sampling pipe (sampling holes)				must be identical
• Humidity ambient condition for detector housing (transient without condensation)				95 ③ % rel. hum.
• Humidity ambient condition detector housing and sampling pipe (continuous)				70 ③ % rel. hum.
Max. loading capacity, relay contact				50 (UL max. 30) VDC
				1 A
				30 W
Max. loading capacity per open collector output (dielectric strength 30 VDC)				100 mA
Plug-in terminals				2.5 mm <sup>2</sup>
Cable entry for cable Ø				Ø 5 – 12 (M20) / Ø 9 – 18 (M25) mm
Sound pressure level				34 dB (A) / 1 m
Housing material				ABS blend, UL 94-V0
Housing colour				grey 280 70 05 / anthracite violet 300 20 05 RAL
Approvals				EN 54-20 / FM 3230 – 3250 / UL 268 7 <sup>th</sup> Ed / ULC-S529 4 <sup>th</sup> Ed
VdS approval				G 212163
Dimensions ASD 533-x (W x H x D)				265 x 397 x 148 mm
Weight ASD 533-x (incl. SSD 533)				3,535 g



### Notices

- ① Power consumption at maximum permitted voltage drop in the electrical installation (decisive value for calculating the conductor cross-section).
- ② May cause the protective circuit to trigger immediately in the case of power supplies with overload protective circuits (primarily in devices with no emergency power supply and output current of < 1.5 A).
- ③ Lower or higher temperature ranges are also possible subject to consultation with the manufacturer. The manufacturer must be consulted if the device is used in the condensation range.

## 14 List of figures

Fig. 1 General operating principle .....	17
Fig. 2 Block diagram .....	18
Fig. 3 Workflow for project-related programming.....	20
Fig. 4 Mechanical design .....	30
Fig. 5 Electrical design .....	32
Fig. 6 "ASD PipeFlow" program interface.....	36
Fig. 7 Examples of planning with "ASD PipeFlow" calculation.....	39
Fig. 8 Examples of planning without "ASD PipeFlow" calculation.....	39
Fig. 9 Sampling pipe definitions .....	40
Fig. 10 Size of sampling holes .....	43
Fig. 11 Variants of equipment monitoring layouts (examples).....	46
Fig. 12 Air recirculation for differing climate zones .....	49
Fig. 13 Workflow for project-specific programming and adjustment .....	50
Fig. 14 Detector housing dimensioned drawing and drilling plan.....	55
Fig. 15 Open, closing and securing the detector housing.....	58
Fig. 16 Mounting position and pipe entries on the detector housing.....	59
Fig. 17 Removing the air outlet pipe plug.....	60
Fig. 18 Turning the labelling strip .....	60
Fig. 19 Cutting the tubes.....	63
Fig. 20 Assembling the tubes .....	63
Fig. 21 Vertical sampling pipe .....	63
Fig. 22 90° bend, branching point .....	63
Fig. 23 Screw-free fastening of a sampling fixture.....	64
Fig. 24 Transition from fittings to flexible tube .....	65
Fig. 25 Creating the sampling holes.....	66
Fig. 26 Mounting clips .....	66
Fig. 27 Using sampling funnels .....	66
Fig. 28 Mounting the ceiling bushing.....	67
Fig. 29 Mounting accessory parts .....	68
Fig. 30 Using the smoke sensors .....	70
Fig. 31 Installing additional modules .....	71
Fig. 32 Types of power supply .....	74
Fig. 33 Reset input.....	74
Fig. 34 Control via supply with relay.....	75
Fig. 35 Control via the "Reset external" input.....	76
Fig. 36 Connection to zone detection.....	77
Fig. 37 Connection on selective identification or addressable loop .....	78
Fig. 38 Interconnection from XLM 35 / ML-SFD / SLM 35 .....	78
Fig. 39 Interconnecting the OC outputs.....	79
Fig. 40 Detector housing opened for commissioning.....	80
Fig. 41 Control and display elements on the AMB 33.....	81
Fig. 42 Configuration overview.....	82
Fig. 43 Workflow for commissioning using EasyConfig .....	84
Fig. 44 Workflow for commissioning with "ASD Config" configuration software.....	85
Fig. 45 View of the control and indicator elements .....	98
Fig. 46 Operation and display XLM 35 / SLM 35 / ML-SFD .....	107
Fig. 47 Operation and display MCM 35.....	108
Fig. 48 SIM 35 indication and control .....	109
Fig. 49 SMM 535 indication and control .....	110
Fig. 50 Removing the aspirating fan unit .....	116
Fig. 51 Removing the airflow sensors .....	117
Fig. 52 Design of an RS-485 ASD network .....	125
Fig. 53 Design of a FidesNet network .....	126

## Document history

First edition      Date 03.02.2012



Index “a”      Date 24.06.2014

Most important changes compared with previous issue:

Section / Fig.	New (n) / changed (c) / deleted (d)		What / Reason
2.2.11	n	New text: “TM for comparing fire characteristic patterns”	Added text
4.11	d	List deleted	No longer necessary
7.3.4	c	Set date/time: seconds added	Correction
7.7.1	c	“Test with test gas” removed	Correction
8.5.3	c	Description of event memory: text correction in first paragraph	Correction
9.4.1	d	“Replace after 8 years of operation” deleted	No longer necessary

Index “b”      Date 16.01.2016

Most important changes compared with the previous issue:

Section / Fig.	New (n) / changed (c) / deleted (d)		What / Reason
4.5.2 / 4.5.4 / 4.5.4.1 / 4.5.5	c	Various adjustments, specifications of the alarm thresholds when planning without “ASD PipeFlow” calculation	Rectification
4.9.1 / 6.6.4.3	c	Notice about screening (observe manufacturer’s specifications of the FACP and SecuriFire/Integral addressable loop)	Rectification
7.3.3 / 7.3.4 / 7.3.5 / 7.3.6 / 7.3.7 / 7.6.1 / 8.5.3.1	c	New table layout with  /  icon	Adaptation
7.3.4 / 8.3	c	Adjusting and polling date and time, now via <b>RE</b> / <b>SE</b>	Correction
7.3.6	c	Under <b>(3)</b> = FW version 01.07.00	Correction
7.7.2 / 8.3	n	New section for test triggers from <i>EasyConfig</i>	Extension
8.5.3.2 / 8.5.3.3	n	New event groups and codes for test triggers from <i>EasyConfig</i> and “ASD Config”	Extension
8.5.5	c	Industrial SD memory cards	Correction
12.1	c	Cable screw union in set of 10, industrial SD memory cards	Correction

## Index "c" Date 31.10.2016

Most important changes compared with the previous issue:

Section / Fig.		New (n) / changed (c) / deleted (d)	What / Reason
2.2.8 / 2.2.14 / 6.5.1 / 7.2.1	n	Activation of the day/night control via OEM input described.	Addition, correction
2.2.12.3 / 2.2.18 / 5.5.12 / 7.2.1, Table C / 7.3.4 / 7.3.5 / 7.3.6 / 7.3.7 / 7.6.1 / 7.7.2 / 7.8 / 8.3 / 8.5.2 / 8.5.3.1 / 8.5.3.2 / 8.5.3.3 / 9.1 / 9.3.1 / 10.3.1	n / c	<b>New "Filter monitoring" function:</b> <ul style="list-style-type: none"> <li>• configuration options</li> <li>• new switch position <b>d</b></li> <li>• new Sec. "Filter monitoring operation"</li> <li>• new event group <b>G16</b> with event code <b>001</b> and <b>016</b></li> <li>• maintenance on dust filter units</li> <li>• new Sec. "Filter replacement for dust filter units"</li> <li>• description of the fault conditions</li> </ul>	Extension
4.2.2	n	New section, Usable accessory materials for the sampling pipe	Addition
4.4.4.3	c	System limitation H / C31, adapted from 240 m to 200 m	Correction
4.6 / Fig. 12 / 7.3.5	n	New section, Monitoring of air-conditioning and ventilation ducts compliant with EN 54-27	Addition
6.4 / 6.6.4.3	n	Notice about "EN 54-17" identification sign	Addition
6.6	c	Text correction "country-specific e.g. EN 54-4"	Correction
6.6.4.3	c	Number of XLM on addressable loop	Correction
7.3.4	c	Correction of the default date on <b>Y13 / M01 / d01</b>	Correction of the year number
8.1 / 8.5.1	c	Lamp test	Addition, correction

## Index "d" Date 30.04.2018

Most important changes compared with previous issue:

Section / Fig.		New (n) / changed (c) / deleted (d)	What / Reason
2.2.6 / 6.5.3 / 7.2.1, Table C / 7.2.2	c	Text corrections ("Sampling tube" → "Sampling pipe")	Correction
2.2.11 / 2.2.15	c	Fault triggering "Dust" only via RIM 35	Supplemental text, correction
2.2.13	c	<b>Autolearning</b> interruption at "Isolate" and "Filter replacement"	Supplemental text, correction
2.2.18 / 7.8	c	Section described better ("Filter monitoring" instead of "Filter function"; the term "workdays" and the prerequisite "time" defined)	Supplemental text, correction
4.2.2 / 4.3.2 / 5.5.12 / Fig. 29	n	Dust filter unit DFU 911 integrated	Extension
4.10 / 13	c	"Sound pressure level" instead of "noise level", value specification corrected	Correction
7.2.1, Table A / B	c	Various corrections of the setting range specifications ("Dirt threshold" / "LS-Ü delay" / "Start time day/night")	Correction
7.2.1, Table C / 7.2.2 / 8.5.3.3 / 10.3.1	c	Text "Smoke sensor" removed, since here not necessary	Correction
8.5.2	c	Displays "Initial reset in progress" / "Test trigger active"	Addition
10.1	c	Procedure for defective units / replacement material	Supplemental text, correction

## Document history

### Index “e” Date 20.06.2019

Most important changes compared with previous issue:

Section / Fig.		New (n) / changed (c) / deleted (d)	What / Reason
General	n	Supplement UL/FM application	Addition
1.5	c	Correction of the rating plates	Correction
2.2.2 / 4.3.1 / Fig. 6 / 4.5.2	c	Application with “ASD PipeFlow”: own device selection in “ASD PipeFlow”	Correction
4.2.1 / 4.7 / Fig. 12 / 5.4	c	Air recirculation, maximal 20 m omitted	Correction/expansion
4.2.2 / 4.10 / 11.4	c	Use in Ex-zones is eliminated	Correction
Formerly 4.6 / Fig. 12 / 7.3.5	d	Section and figure “Application EN 54-27” deleted	Correction
4.9.2 / 13	c	RIM current consumption (all relays triggered)	Addition
6.6.4.3	c	Number of XLM on addressable loop	Correction
6.6.5	c	OC outputs short-circuit-proof (new AMB)	Correction
9.1 / 9.3, item 9	n	Notice about filter service lives in DFU 911 Data Sheet	Addition
13	c	Name of standard for protection type/ambient conditions	Correction

### Index “f” Date 13.12.2021

Most important changes compared with previous issue:

Section / Fig.		New (n) / changed (c) / deleted (d)	What / Reason
Various	n	Inclusion of ML-SFD additional module in Section / Fig.: 1.1 / 1.4 / Fig. 2 / 2.2.9 / 2.2.13 / 2.2.12.3 / 2.2.15 / 3.1 / 3.2 / Fig. 5 / 3.4 / 4.2 / 4.9.1 / 4.9.2 / 6.4 / Fig. 31 / 6.5.2 / 6.6.2 / 6.6.3.2 / Fig. 35 / 6.6.4.3 / Fig. 38 / 7.1 / 7.2 / 7.3.7 / 7.4.4 / 7.7.2 / 8.5.3.2 / 8.5.3.3 / 8.5.4 / Fig. 46 / 8.7 / 10.3.1 / 12.1 / 13	Extension
Various	n	Inclusion of UIM additional module in Section / Fig.: 1.1 / 1.4 / Fig. 2 / 2.2.15 / 3.1 / 3.2 / Fig. 5 / 3.4 / 6.4 / Fig. 31 / 6.4 / 7.3.7 / 8.5.3.2 / 8.5.3.3 / 10.3.1	Extension
2.2.17.3	c	Description “initial reset,” text reformulated	Correction
Various	c	Filter FBL, FBX, DFU 535 omitted from Section / Fig.: 2.2.17.3 / 4.2.2 / 4.3.1 / 4.3.2 / 4.4.1 / 4.4.4.3 / 4.10 / 5.4.2 / 5.5.12 / Fig. 29 / 7.8 / 9.3 / 9.3.1 / 10.3.1 / 11.2	Correction
4.2.2	c	Supplement and correction of the table “Usable accessory materials for the sampling pipe” (filters / ADBs)	Correction / supplement
4.4.2	c	Room monitoring of high rooms in accordance with the “FIA Code of Practice”	Correction
5.5.5 / 5.5.6 / Fig. 24 / Fig. 25 / 9.5.1	c	“Clamp” omitted (pipe clamp)	Correction
Fig. 29	c	New ADBs (instead of ADB 01A/02)	Correction / supplement
8.5.3.3	c	<b>G30</b> and <b>G40</b> Event code <b>001</b> , Notice on DFU 911S supplement	Correction / supplement
10.3.1	c	Text adjustment for <b>G70</b> and <b>G80</b> , meaning (“Fault” omitted)	Correction
12.1	n	New Art. number RIM 35	Addition
13	c	Addition of the VdS G number	Addition

**Index “g”**      **Date 31.10.2023****Most important changes compared with previous issue:**

<b>Section / Fig.</b>	<b>New (n) / changed (c) / deleted (d)</b>		<b>What / Reason</b>
Various	n	Extension with device variant ASD 533-2 Inclusion of additional modules SIM 35 / SMM 535 Inclusion of ASD networking / FidesNet networking	Extension